

AVX Surface Mount Ceramic Capacitor Products



Version 6.1

AVX
A KYOCERA GROUP COMPANY

Ceramic Chip Capacitors



Table of Contents

How to Order - AVX Part Number Explanation	2-3
C0G (NP0) Dielectric	
General Specifications	4
Specifications and Test Methods	5
Capacitance Range	6-7
U Dielectric	
General Information	8
Capacitance Range	9-10
Designer Kits	11
X8R Dielectric	
General Specifications	12-13
X7R Dielectric	
General Specifications	14
Specifications and Test Methods	15
Capacitance Range	16-17
X7S Dielectric	
General Specifications	18
Specifications and Test Methods	19
Capacitance Range	20
X5R Dielectric	
General Specifications	21
Specifications and Test Methods	22
Capacitance Range	23
Y5V Dielectric	
General Specifications	24
Specifications and Test Methods	25
Capacitance Range	26
MLCC Tin/Lead Termination (LD Series)	
General Specifications	27
Capacitance Range	28-33
MLCC Low Profile	
General Specifications / Capacitance Range	34
Automotive MLCC	
General Specifications	35-36
Capacitance Range	37-39
APS for COTS+ Applications	
General Specifications	40
Capacitance Range	41-42
MLCC with FLEXITERM™	
General Description	43
Specifications and Test Methods	44-45
Capacitance Range	46-47
Capacitor Array	
Capacitor Array (IPC)	48-51
Automotive Capacitor Array (IPC)	52
Multi-Value Capacitor Array (IPC)	53
Part and Pad Layout Dimensions	54
Low Inductance Capacitors	
Introduction	55-56
LICC (Low Inductance Chip Capacitors)	57-60
IDC (InterDigitated Capacitors)	61-64
LICA (Low Inductance Decoupling Capacitor Arrays)	65-66
High Voltage MLC Chips	
600V to 5000V Applications	67-68
Tin/Lead Termination "B" - 600V to 5000V Applications	69-70
CECC Ceramic Chips	
High Reliability CECC Ceramic Chips Capacitors for Military & Avionics Applications	71
MIL-PRF-55681/Chips	
CDR01 thru CDR06	72-73
CDR31 thru CDR35	74-77
Packaging of Chip Components	78
Embossed Carrier Configuration - 8 & 12mm Tape	79
Paper Carrier Configuration - 8 & 12mm Tape	80
Bulk Case Packaging	81
Basic Capacitor Formulas	82
General Description	83-87
Surface Mounting Guide	88-92



How to Order



Part Number Explanation

Commercial Surface Mount Chips

EXAMPLE: 08055A101JAT2A

0805	5	A	101	J*	A	T	2	A
Size (L" x W")	Voltage	Dielectric	Capacitance	Tolerance	Failure Rate	Terminations	Packaging Available	Special Code
0201 0402 0603 0805 1206 1210 1812 1825 2220 2225	4 = 4V 6 = 6.3V Z = 10V Y = 16V J = 25V D = 35V 5 = 50V 1 = 100V 2 = 200V 7 = 500V	A = NP0(C0G) C = X7R D = X5R F = X8R G = Y5V U = U Series W = X6S Z = X7S	2 Sig. Fig + No. of Zeros Examples: 100 = 10 pF 101 = 100 pF 102 = 1000 pF 223 = 22000 pF 224 = 220000 pF 105 = 1µF 106 = 10µF 107 = 100µF For values below 10 pF, use "R" in place of Decimal point, e.g., 9.1 pF = 9R	B = ±.10 pF C = ±.25 pF D = ±.50 pF F = ±1% (≥ 10 pF) G = ±2% (≥ 10 pF) J = ±5% K = ±10% M = ±20% Z = +80%, -20% P = +100%, -0%	A = N/A 4 = Automotive	T = Plated Ni and Sn 7 = Gold Plated U = Conductive Epoxy for Hybrid Applications Z = FLEXITERM™ X = FLEXITERM™ with 5% min lead (X7R & X8R only)	2 = 7" Reel 4 = 13" Reel 7 = Bulk Cass. 9 = Bulk	A = Std.
<div style="border: 1px solid black; padding: 5px; width: fit-content;"> <p>Contact Factory for Special Voltages</p> <p>F = 63V 9 = 300V * = 75V X = 350V E = 150V 8 = 400V V = 250V</p> </div>								
						<p>Contact Factory For 1 = Pd/Ag Term</p>		

* B, C & D tolerance for ≤10 pF values.

Standard Tape and Reel material (Paper/Embossed) depends upon chip size and thickness.

See individual part tables for tape material type for each capacitance value.

NOTE: Contact factory for availability of Termination and Tolerance Options for Specific Part Numbers. For Tin/Lead Terminations, please refer to LD Series

High Voltage MLC Chips

EXAMPLE: 1808AA271KA11A

1808	A	A	271	K	A	T	1	A
AVX Style	Voltage	Temperature Coefficient	Capacitance Code	Capacitance Tolerance	Failure Rate	Termination	Packaging/Marking	Special Code
0805 1206 1210 1808 1812 1825 2220 2225 3640	C = 600V/630V A = 1000V S = 1500V G = 2000V W = 2500V H = 3000V J = 4000V K = 5000V	A = C0G C = X7R	(2 significant digits + no. of zeros) Examples: 10 pF = 100 100 pF = 101 1,000 pF = 102 22,000 pF = 223 220,000 pF = 224 µF = 105	J = ±5% K = ±10% M = ±20% X7R: K = ±10% M = ±20% Z = +80%, -20%	A=Not Applicable	1 = Pd/Ag T = Plated Ni and Sn B = 5% Min Pb Z = FLEXITERM™ X = FLEXITERM™ with 5% min lead (X7R only)	1 = 7" Reel 3 = 13" Reel 9 = Bulk	A = Standard

NOTE: Contact factory for availability of Termination and Tolerance Options for Specific Part Numbers. For Tin/Lead Terminations, please refer to LD Series



How to Order



Part Number Explanation

Capacitor Array

EXAMPLE: W2A43C103MAT2A

W	2	A	4	3	C	103	M	A	T	2A
Style	Case Size	Array	Number of Caps	Voltage	Dielectric	Capacitance Code (In pF)	Capacitance Tolerance	Failure Rate	Termination Code	Packaging & Quantity Code
1 = 0405 2 = 0508 3 = 0612	1 = 0405 2 = 0508 3 = 0612			Z = 10V Y = 16V 3 = 25V 5 = 50V 1 = 100V	A = NPO C = X7R D = X5R	2 Sig. Digits + Number of Zeros	J = ±5% K = ±10% M = ±20%	A = Commercial 4 = Automotive	T = Plated Ni and Sn Z = FLEXITERM™ B = 5% min lead X = FLEXITERM™ with 5% min lead	2A = 7" Reel (4000) 4A = 13" Reel (10000) 2F = 7" Reel (1000)

NOTE: Contact factory for availability of Termination and Tolerance Options for Specific Part Numbers.

Low Inductance Capacitors (LICC)

EXAMPLE: 0612ZD105MAT2A

0612	Z	D	105	M	A	T	2	A
Size	Voltage	Dielectric	Capacitance Code (In pF)	Capacitance Tolerance	Failure Rate	Terminations	Packaging Available	Thickness
0306 0508 0612 LD16 LD17 LD18	6 = 6.3V Z = 10V Y = 16V 3 = 25V 5 = 50V	C = X7R D = X5R	2 Sig. Digits + Number of Zeros	K = ±10% M = ±20%	A = N/A	T = Plated Ni and Sn B = 5% min lead	2 = 7" Reel 4 = 13" Reel	See Page 60 for Codes

NOTE: Contact factory for availability of Termination and Tolerance Options for Specific Part Numbers.

Interdigitated Capacitors (IDC)

EXAMPLE: W3L16D225MAT3A

W	3	L	1	6	D	225	M	A	T	3	A
Style	Case Size	Low Inductance	Number of Terminals	Voltage	Dielectric	Capacitance Code (In pF)	Capacitance Tolerance	Failure Rate	Termination	Packaging Available	Thickness
W = RoHS L = SnPb	2 = 0508 3 = 0612	ESL = 50pH ESL = 60pH	1 = 8 Terminals	4 = 4V 6 = 6.3V Z = 10V Y = 16V	C = X7R D = X5R	2 Sig. Digits + Number of Zeros	M = ±20%	A = N/A	T = Plated Ni and Sn B = 5% min Lead	1=7" Reel 3=13" Reel	Max. Thickness mm (in.) A=0.95 (0.037) S=0.55 (0.022)

NOTE: Contact factory for availability of Termination and Tolerance Options for Specific Part Numbers.

Low Inductance Decoupling Capacitor Arrays (LICA)

EXAMPLE: LICA3T183M3FC4AA

LICA	3	T	102	M	3	F	C	4	A	A
Style & Size	Voltage	Dielectric	Cap/Section (EIA Code)	Capacitance Tolerance	Height Code	Termination	Reel Packaging	# of Caps/Part	Inspection Code	Code Face
	5V = 9 10V = Z 25V = 3	D = X5R T = T55T S = High K T55T	102 = 1000 pF 103 = 10 nF 104 = 100 nF	M = ±20% P = GMV	6 = 0.500mm 3 = 0.650mm 1 = 0.875mm 5 = 1.100mm 7 = 1.600mm	F = C4 Solder Balls- 97Pb/3Sn H = C4 Solder Balls-Low ESR P = Cr-Cu-Au N = Cr-Ni-Au X = None	M = 7" Reel R = 13" Reel 6 = 2"x2" Waffle Pack 8 = 2"x2" Black Waffle Pack 7 = 2"x2" Waffle Pack w/ termination facing up A = 2"x2" Black Waffle Pack w/ termination facing up C = 1"x4" Waffle Pack w/ clear lid	1 = one 2 = two 4 = four	A = Standard B = Established Reliability Testing	A = Bar B = No Bar C = Dot, S55S Dielectrics D = Triangle

NOTE: Contact factory for availability of Termination and Tolerance Options for Specific Part Numbers.



COG (NP0) Dielectric



General Specifications

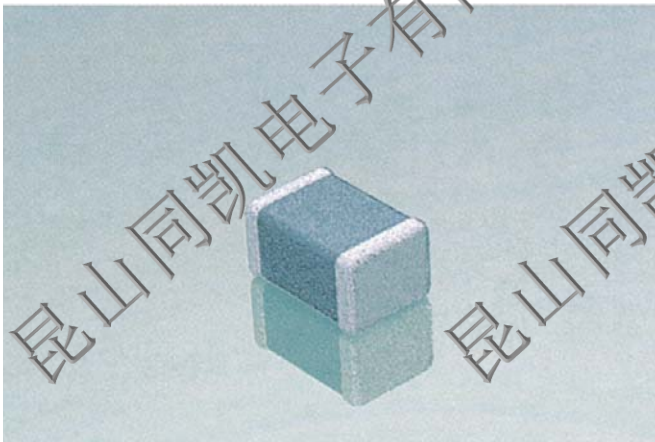

COG (NP0) is the most popular formulation of the "temperature-compensating," EIA Class I ceramic materials. Modern COG (NP0) formulations contain neodymium, samarium and other rare earth oxides.

COG (NP0) ceramics offer one of the most stable capacitor dielectrics available. Capacitance change with temperature is $0 \pm 30 \text{ ppm}/^\circ\text{C}$ which is less than $\pm 0.3\% \Delta C$ from -55°C to $+125^\circ\text{C}$. Capacitance drift or hysteresis for COG (NP0) ceramics is negligible at less than $\pm 0.05\%$ versus up to $\pm 2\%$ for films. Typical capacitance change with life is less than $\pm 0.1\%$ for COG (NP0), one-fifth that shown by most other dielectrics. COG (NP0) formulations show no aging characteristics.

PART NUMBER (see page 2 for complete part number explanation)

0805	5	A	101	J	A	T	2	A
Size (L" x W")	Voltage 6.3V = 6 10V = Z 16V = Y 25V = 3 50V = 5 100V = 1 200V = 2 500V =	Dielectric COG (NP0) = A	Capacitance Code (In pF) 2 Sig. Digits + Number of Zeros	Capacitance Tolerance B = $\pm 10 \text{ pF}$ ($< 10 \text{ pF}$) C = $\pm 25 \text{ pF}$ ($< 10 \text{ pF}$) D = $\pm 50 \text{ pF}$ ($< 10 \text{ pF}$) F = $\pm 1\%$ ($\geq 10 \text{ pF}$) G = $\pm 2\%$ ($\geq 10 \text{ pF}$) J = $\pm 5\%$ K = $\pm 10\%$	Failure Rate A = Not Applicable	Terminations T = Plated Ni and Sn 7 = Gold Plated	Packaging 2 = 7" Reel 4 = 13" Reel 7 = Bulk Cass. 9 = Bulk	Special Code A = Std. Product
						Contact Factory For 1 = Pd/Ag Term	Contact Factory For Multiples	

NOTE: Contact factory for availability of Termination and Tolerance Options for Specific Part Numbers. Contact factory for non-specified capacitance values.

Temperature Coefficient

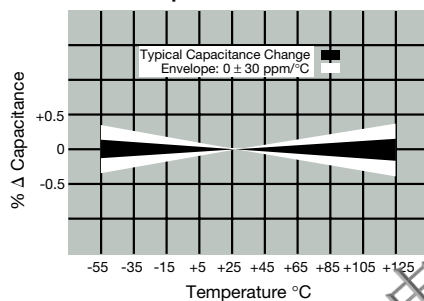

Δ Capacitance vs. Frequency

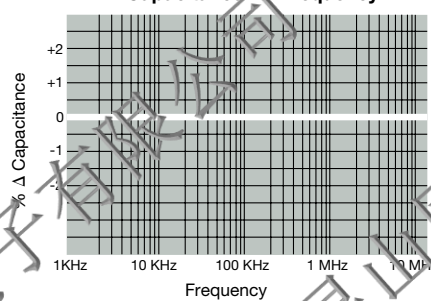

Insulation Resistance vs Temperature

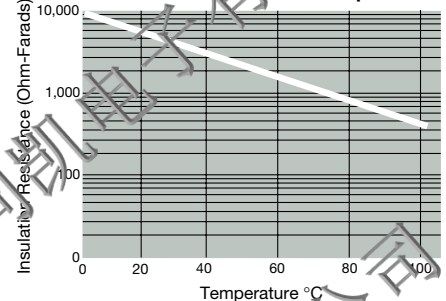

Variation of Impedance with Capacitance Value
Impedance vs. Frequency
0805 - COG (NP0)
10 pF vs. 100 pF vs. 1000 pF

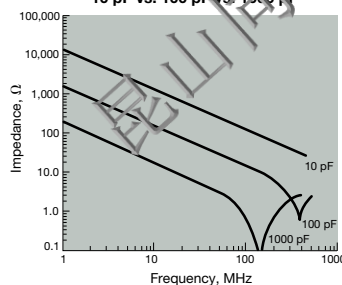

Variation of Impedance with Chip Size
Impedance vs. Frequency
1000 pF - COG (NP0)

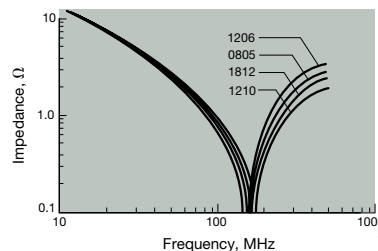

Variation of Impedance with Ceramic Formulation
Impedance vs. Frequency
1000 pF - COG (NP0) vs X7R
0805

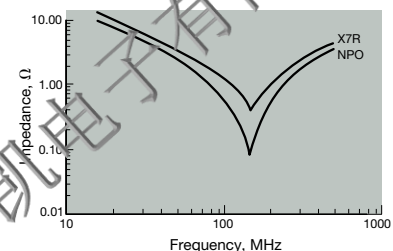

C0G (NP0) Dielectric

Specifications and Test Methods



Parameter/Test		NP0 Specification Limits	Measuring Conditions	
Operating Temperature Range		-55°C to +125°C	Temperature Cycle Chamber	
Capacitance		Within specified tolerance	Freq.: 1.0 MHz \pm 10% for cap \leq 1000 pF 1.0 kHz \pm 10% for cap > 1000 pF Voltage: 1.0Vrms \pm .2V	
Q		<30 pF: Q \geq 400+20 x Cap Value \geq 30 pF: Q \geq 1000		
Insulation Resistance		100,000M Ω or 1000M Ω - μ F, whichever is less	Charge device with rated voltage for 60 \pm 5 secs @ room temp/humidity	
Dielectric Strength		No breakdown or visual defects	Charge device with 300% of rated voltage for 1-5 seconds, w/charge and discharge current limited to 50 mA (max) Note: Charge device with 50% of rated voltage for 500V devices.	
Resistance to Flexure Stresses	Appearance	No defects		
	Capacitance Variation	\pm 5% or \pm .5 pF, whichever is greater		
	Q	Meets Initial Values (As Above)		
	Insulation Resistance	\geq Initial Value x 0.3		
Solderability		\geq 95% of each terminal should be covered with fresh solder	Dip device in eutectic solder at 230 \pm 5°C for 5.0 \pm 0.5 seconds	
Resistance to Solder Heat	Appearance	No defects, \leq 2% leaching of either end terminal	Dip device in eutectic solder at 260°C for 60 seconds. Store at room temperature for 24 \pm 2 hours before measuring electrical properties.	
	Capacitance Variation	\leq \pm 2.5% or \pm .25 pF, whichever is greater		
	Q	Meets Initial Values (As Above)		
	Insulation Resistance	Meets Initial Values (As Above)		
Thermal Shock	Appearance	No visual defects	Step 1: -55°C \pm 2°	30 \pm 3 minutes
	Capacitance Variation	\leq \pm 2.5% or \pm .25 pF, whichever is greater	Step 2: Room Temp	\leq 3 minutes
	Q	Meets Initial Values (As Above)	Step 3: +125°C \pm 2°	30 \pm 3 minutes
	Insulation Resistance	Meets Initial Values (As Above)	Step 4: Room Temp	\leq 3 minutes
	Dielectric Strength	Meets Initial Values (As Above)	Repeat for 5 cycles and measure after 24 hours at room temperature	
	Load Life	Appearance	No visual defects	Charge device with twice rated voltage in test chamber set at 125°C \pm 2°C for 1000 hours (+48, -0). Remove from test chamber and stabilize at room temperature for 24 hours before measuring.
Capacitance Variation		\leq \pm 3.0% or \pm .3 pF, whichever is greater		
Q (C=Nominal Cap)		\geq 30 pF: Q \geq 350 \geq 10 pF, <30 pF: Q \geq 275 +5C/2 <10 pF: Q \geq 200 +10C		
Insulation Resistance		Initial Value x 0.3 (See Above)		
Dielectric Strength		Meets Initial Values (As Above)		
Load Humidity	Appearance	No visual defects	Store in a test chamber set at 85°C \pm 2°C/ 85% \pm 5% relative humidity for 1000 hours (+48, -0) with rated voltage applied. Remove from chamber and stabilize at room temperature for 24 \pm 2 hours before measuring.	
	Capacitance Variation	\leq \pm 5.0% or \pm .5 pF, whichever is greater		
	Q	\geq 30 pF: Q \geq 350 \geq 10 pF, <30 pF: Q \geq 275 +5C/2 <10 pF: Q \geq 200 +10C		
	Insulation Resistance	\geq Initial Value x 0.3 (See Above)		
	Dielectric Strength	Meets Initial Values (As Above)		

COG (NP0) Dielectric

Capacitance Range



PREFERRED SIZES ARE SHADED

SIZE		0201			0402			0603				0805				1206						
Soldering		Reflow Only			Reflow Only			Reflow Only				Reflow/Wave				Reflow/Wave						
Packaging		All Paper			All Paper			All Paper				Paper/Embossed				Paper/Embossed						
(L) Length	MM (in.)	0.60 ± 0.03 (0.024 ± 0.001)			1.00 ± 0.10 (0.040 ± 0.004)			1.60 ± 0.15 (0.063 ± 0.006)				2.01 ± 0.20 (0.079 ± 0.008)				3.20 ± 0.20 (0.126 ± 0.008)						
(W) Width	MM (in.)	0.30 ± 0.03 (0.011 ± 0.001)			0.50 ± 0.10 (0.020 ± 0.004)			0.80 ± 0.15 (0.032 ± 0.006)				1.25 ± 0.20 (0.049 ± 0.008)				1.60 ± 0.20 (0.063 ± 0.008)						
(t) Terminal	MM (in.)	0.15 ± 0.05 (0.006 ± 0.002)			0.25 ± 0.15 (0.010 ± 0.006)			0.35 ± 0.15 (0.014 ± 0.006)				0.50 ± 0.25 (0.020 ± 0.010)				0.50 ± 0.25 (0.020 ± 0.010)						
WVDC		10	16	25	16	25	50	6.3	25	50	100	16	25	50	100	200	16	25	50	100	200	500
Cap (pF)	0.5			A	C	C	C	G	G	G	G	J	J	J	J	J	J	J	J	J	J	J
	1.0			A	C	C	C	G	G	G	G	J	J	J	J	J	J	J	J	J	J	J
	1.2			A	C	C	C	G	G	G	G	J	J	J	J	J	J	J	J	J	J	J
	1.5	A	A	A	C	C	C	G	G	G	G	J	J	J	J	J	J	J	J	J	J	J
	1.8	A	A	A	C	C	C	G	G	G	G	J	J	J	J	J	J	J	J	J	J	J
	2.2	A	A	A	C	C	C	G	G	G	G	J	J	J	J	J	J	J	J	J	J	J
	2.7	A	A	A	C	C	C	G	G	G	G	J	J	J	J	J	J	J	J	J	J	J
	3.3	A	A	A	C	C	C	G	G	G	G	J	J	J	J	J	J	J	J	J	J	J
	3.9	A	A	A	C	C	C	G	G	G	G	J	J	J	J	J	J	J	J	J	J	J
	4.7	A	A	A	C	C	C	G	G	G	G	J	J	J	J	J	J	J	J	J	J	J
	5.6	A	A	A	C	C	C	G	G	G	G	J	J	J	J	J	J	J	J	J	J	J
	6.8	A	A	A	C	C	C	G	G	G	G	J	J	J	J	J	J	J	J	J	J	J
	8.2	A	A	A	C	C	C	G	G	G	G	J	J	J	J	J	J	J	J	J	J	J
	10	A	A	A	C	C	C	G	G	G	G	J	J	J	J	J	J	J	J	J	J	J
	12	A	A	A	C	C	C	G	G	G	G	J	J	J	J	J	J	J	J	J	J	J
	15	A	A	A	C	C	C	G	G	G	G	J	J	J	J	J	J	J	J	J	J	J
	18	A	A	A	C	C	C	G	G	G	G	J	J	J	J	J	J	J	J	J	J	J
	22	A	A	A	C	C	C	G	G	G	G	J	J	J	J	J	J	J	J	J	J	J
	27	A	A	A	C	C	C	G	G	G	G	J	J	J	J	J	J	J	J	J	J	J
	33	A	A	A	C	C	C	G	G	G	G	J	J	J	J	J	J	J	J	J	J	J
	39	A	A	A	C	C	C	G	G	G	G	J	J	J	J	J	J	J	J	J	J	J
	47	A	A	A	C	C	C	G	G	G	G	J	J	J	J	J	J	J	J	J	J	J
	56	A	A	A	C	C	C	G	G	G	G	J	J	J	J	J	J	J	J	J	J	J
	68	A	A	A	C	C	C	G	G	G	G	J	J	J	J	J	J	J	J	J	J	J
	82	A	A	A	C	C	C	G	G	G	G	J	J	J	J	J	J	J	J	J	J	J
	100	A	A	A	C	C	C	G	G	G	G	J	J	J	J	J	J	J	J	J	J	J
	120				C	C	C	G	G	G	G	J	J	J	J	J	J	J	J	J	J	J
	150				C	C	C	G	G	G	G	J	J	J	J	J	J	J	J	J	J	J
	180				C	C	C	G	G	G	G	J	J	J	J	J	J	J	J	J	J	J
	220				C	C	C	G	G	G	G	J	J	J	J	J	J	J	J	J	J	J
	270							G	G	G	G	J	J	J	J	M	J	J	J	J	J	M
	330							G	G	G	G	J	J	J	J	M	J	J	J	J	J	M
	390							G	G	G	G	J	J	J	J	M	J	J	J	J	J	M
	470							G	G	G	G	J	J	J	J	M	J	J	J	J	J	M
	560							G	G	G	G	J	J	J	J	M	J	J	J	J	J	M
	680							G	G	G	G	J	J	J	J		J	J	J	J	J	P
	820							G	G	G	G	J	J	J	J		J	J	J	J	J	P
	1000							G	G	G	G	J	J	J	J		J	J	J	J	J	Q
	1200											J	J	J	J		J	J	J	J	J	Q
	1500											J	J	J	J		J	J	J	J	J	Q
	1800											J	J	J	J		J	J	J	M	M	
	2200											J	J	J	J		J	J	J	M	P	
	2700											J	J	J	J		J	J	J	M	P	
	3300											J	J	J	J		J	J	J	M	P	
	3900											J	J	J	J		J	J	J	M	P	
	4700											J	J	J	J		J	J	J	M	P	
	5600											J	J	J	J		J	J	J	M		
	6800											J	J	J	J		M	M				
	8200											J	J	J	J		M	M				
Cap (µF)	0.010																					
	0.012																					
	0.015																					
	0.018																					
	0.022																					
	0.027																					
	0.033																					
	0.039																					
	0.047																					
	0.068																					
	0.082																					
	0.1																					
WVDC		10	16	25	16	25	50	6.3	25	50	100	16	25	50	100	200	16	25	50	100	200	500
SIZE	0201			0402			0603				0805				1206							
Letter	A	C	E	G	J	K	M	N	P	Q	X	Y	Z									
Max. Thickness	0.33 (0.013)	0.56 (0.022)	0.71 (0.028)	0.86 (0.034)	0.94 (0.037)	1.02 (0.040)	1.27 (0.050)	1.40 (0.055)	1.52 (0.060)	1.78 (0.070)	2.00 (0.080)	2.54 (0.100)	2.79 (0.110)									
	PAPER						EMBOSS/SEL															

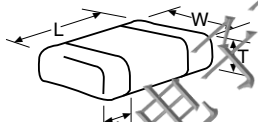

RF/Microwave C0G (NP0) Capacitors



Ultra Low ESR, "U" Series, C0G (NP0) Chip Capacitors

GENERAL INFORMATION

"U" Series capacitors are C0G (NP0) chip capacitors specially designed for "Ultra" low ESR for applications in the communications market. Max ESR and effective capacitance

are met on each value producing lot to lot uniformity. Sizes available are EIA chip sizes 0603, 0805, and 1210.

DIMENSIONS (inches (millimeters))

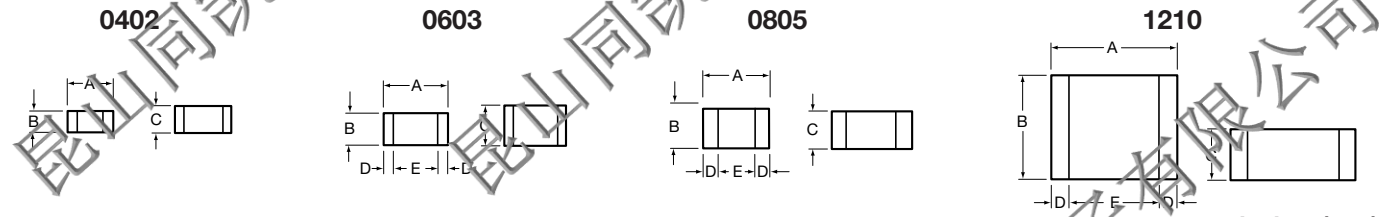

Size	A	B	C	D	E
0402	0.039±0.004 (1.00±0.1)	0.020±0.004 (0.50±0.1)	0.024 (0.6) max	N/A	N/A
0603	0.060±0.010 (1.52±0.25)	0.030±0.010 (0.76±0.25)	0.036 (0.91) max	0.010±0.005 (0.25±0.13)	0.030 (0.76) min
0805	0.079±0.008 (2.01±0.2)	0.049±0.008 (1.25±0.2)	0.040±0.005 (1.02±0.127)	0.020±0.010 (0.51±0.255)	0.020 (0.51) min
1210	0.126±0.008 (3.2±0.2)	0.098±0.008 (2.49±0.2)	0.050±0.005 (1.27±0.127)	0.025±0.015 (0.635±0.381)	0.040 (1.02) min

HOW TO ORDER

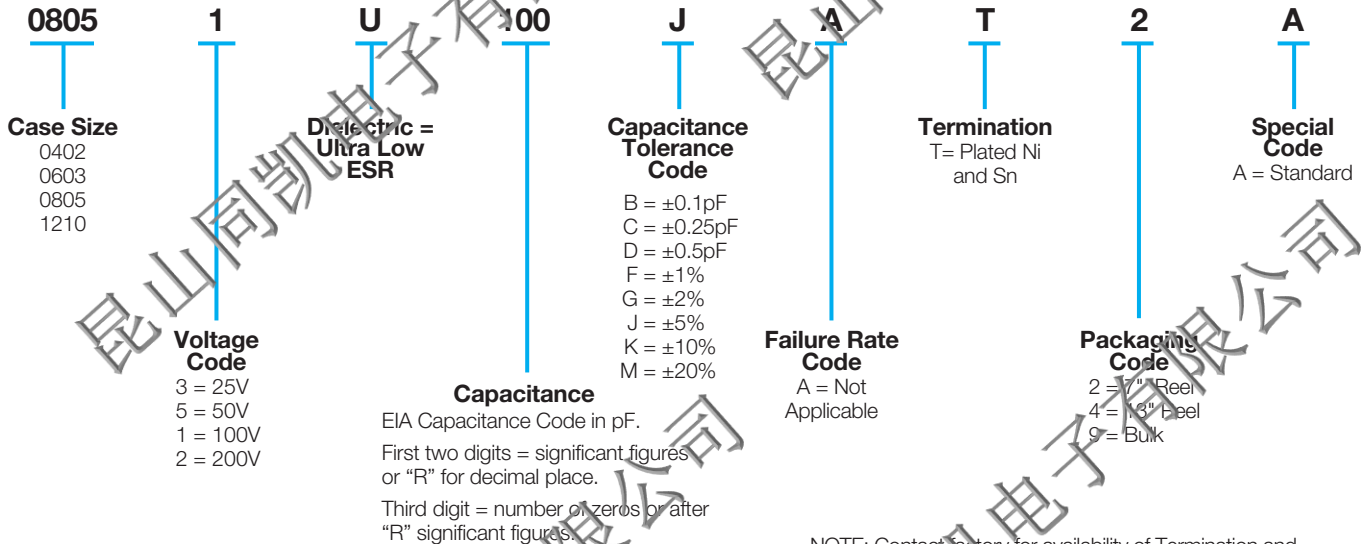

NOTE: Contact factory for availability of Termination and Tolerance Options for Specific Part Numbers.

ELECTRICAL CHARACTERISTICS

Capacitance Values and Tolerances:

- Size 0402 - 0.2 pF to 22 pF @ 1 MHz
- Size 0603 - 1.0 pF to 100 pF @ 1 MHz
- Size 0805 - 1.6 pF to 160 pF @ 1 MHz
- Size 1210 - 2.4 pF to 1000 pF @ 1 MHz

Temperature Coefficient of Capacitance (TC):

0±30 ppm/°C (-55° to +125°C)

Insulation Resistance (IR):

- 10¹² Ω min. @ 25°C and rated WVDC
- 10¹¹ Ω min. @ 125°C and rated WVDC

Working Voltage (WVDC):

- | Size | Working Voltage |
|------|-------------------|
| 0402 | 50, 25 WVDC |
| 0603 | 200, 100, 50 WVDC |
| 0805 | 200, 100 WVDC |
| 1210 | 200, 100 WVDC |

Dielectric Working Voltage (DWV):

250% of rated WVDC

Equivalent Series Resistance Typical (ESR):

- 0402 - See Performance Curve, page 9
- 0603 - See Performance Curve, page 9
- 0805 - See Performance Curve, page 9
- 1210 - See Performance Curve, page 9

Marking: Laser marking EIA J marking standard (except 0603) (capacitance code and tolerance upon request).

MILITARY SPECIFICATIONS

Meets or exceeds the requirements of MIL-C-55681

RF/Microwave C0G (NP0) Capacitors



Ultra Low ESR, "U" Series, C0G (NP0) Chip Capacitors

TYPICAL
SERIES RESONANT FREQUENCY
"U" SERIES CHIP

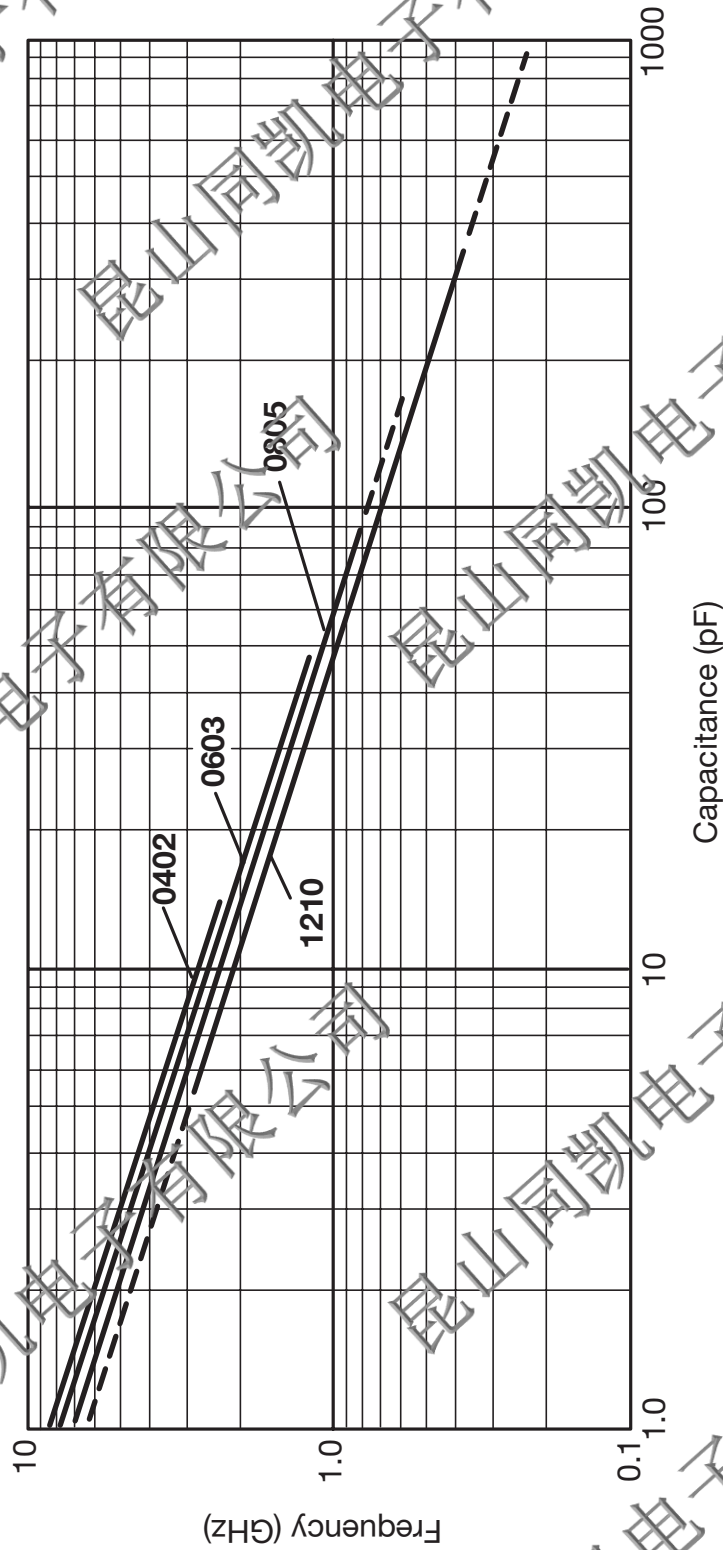

Designer Kits

Communication Kits “U” Series



“U” SERIES KITS

Solder Plated, Nickel Barrier

0402

Kit 5000 UZ*			
Cap. Value pF	Tol.†	Cap. Value pF	Tol.†
0.5	B	4.7	B
1.0	B	5.6	B
1.5	B	6.8	B
1.8	B	8.2	B
2.2	B	10.0	J
2.4	B	12.0	J
3.0	B	15.0	J
3.6	B		

* 150 Capacitors 10 each of 15 values.

0603

Kit 4000 UZ**			
Cap. Value pF	Tol.†	Cap. Value pF	Tol.†
1.0	±.25pF	6.8	±.25pF
1.2	±.25pF	7.5	±.25pF
1.5	±.25pF	8.2	±.25pF
1.8	±.25pF	10.0	±5%
2.0	±.25pF	12.0	±5%
2.4	±.25pF	15.0	±5%
2.7	±.25pF	18.0	±5%
3.0	±.25pF	22.0	±5%
3.3	±.25pF	27.0	±5%
3.9	±.25pF	33.0	±5%
4.7	±.25pF	39.0	±5%
5.6	±.25pF	47.0	±5%

** 240 Capacitors 10 each of 24 values.

0805

Kit 3000 UZ***					
Cap. Value pF	Tol.†	Cap. Value pF	Tol.†	Cap. Value pF	Tol.†
1.0	C	7.5	C	33	J
1.5	C	8.2	C	36	J
2.2	C	9.1	C	39	J
2.4	C	10.0	J	47	J
2.7	C	12.0	J	56	J
3.0	C	15.0	J	68	J
3.3	C	18.0	J	82	J
3.9	C	22.0	J	100	J
4.7	C	24.0	J	130	J
5.6	C	27.0	J	160	J

*** 300 Capacitors 10 each of 30 values.

1210

Kit 3500 UZ***					
Cap. Value pF	Tol.†	Cap. Value pF	Tol.†	Cap. Value pF	Tol.†
2.2	C	18	J	68	J
2.7	C	20	J	82	J
4.7	C	24	J	100	J
5.6	C	27	J	120	J
6.8	C	30	J	150	J
8.2	C	36	J	240	J
9.1	C	39	J	300	J
10	J	47	J	390	J
13	J	51	J	470	J
15	J	56	J	680	J

†Tolerance – B = ±0.1pF
C = ±0.25pF
J = ±5%

X8R Dielectric

General Specifications

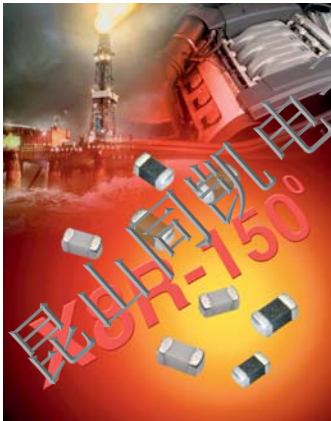

AVX have developed a range of multilayer ceramic capacitors designed for use in applications up to 150°C. These capacitors are manufactured with an X8R dielectric material which has a capacitance variation of $\pm 15\%$ between -55°C and $+150^\circ\text{C}$.

The need for X8R performance has been driven by customer requirements for parts that operate at elevated temperatures. They provide a highly reliable capacitor with low loss and stable capacitance over temperature.

They are ideal for automotive, under the hood sensors, measure while drilling and log while drilling. Typical applications include wire line logging tools such as gamma ray receivers, acoustic transceivers and micro-resistivity tools. They can also be used as bulk capacitors for high temperature camera modules.

X8R capacitors are available as standard and Automotive AEC-Q200 qualified parts. Optional termination systems, tin, FLEXITERM™ and conductive epoxy for hybrid applications are available. Providing this series with our FLEXITERM™ termination system provides further advantage to customers by way of enhanced resistance to both, temperature cycling and mechanical damage.

PART NUMBER (see page 2 for complete part number explanation)

0805

Size
0603
0805
1206

5

Voltage
25V = 3
50V = 5

F

Dielectric
X8R = F

104

Capacitance Code (in pF)
2 Sig. Digits + Number of Zeros
e.g. 10 μF = 106

K

Capacitance Tolerance
J = $\pm 5\%$
K = $\pm 10\%$
M = $\pm 20\%$

4

Failure Rate
4 = Automotive
A = Not Applicable

T

Terminations
T = Plated Ni and Sn
Z = FLEXITERM™
U = Conductive Epoxy for Hybrid apps

2

Packaging
2 = 7" Reel
4 = 13" Reel

A

Special Code
A = Std. Product

NOTE: Contact factory for availability of Termination and Tolerance Options for Specific Part Numbers.

SIZE		0603		0805		1206	
Cap	WVDC	25V	50V	25V	50V	25V	50V
271	270	G	G	J	J		
331	330	G	G	J	J		
471	470	G	G	J	J		
681	680	G	G	J	J		
102	1000	G	G	J	J	J	J
152	1500	G	G	J	J	J	J
182	1800	G	G	J	J	J	J
222	2200	G	G	J	J	J	J
272	2700	G	G	J	J	J	J
332	3300	G	G	J	J	J	J
392	3900	G	G	J	J	J	J
472	4700	G	G	J	J	J	J
562	5600	G	G	J	J	J	J
682	6800	G	G	J	J	J	J
822	8200	G	G	J	J	J	J
103	0.01	G	G	J	J	J	J
123	0.012	G	G	J	J	J	J
153	0.015	G	G	J	J	J	J
183	0.018	G	G	J	J	J	J
223	0.022	G	G	J	J	J	J
273	0.027	G	G	J	J	J	J
333	0.033	G	G	J	J	J	J
393	0.039	G	G	J	J	J	J
473	0.047	G	G	J	J	J	J
563	0.056	G	G	N	N	M	M
683	0.068	G	G	N	N	M	M
823	0.082	G	G	N	N	M	M
104	0.1	G	G	N	N	M	M
124	0.12	G	G	N	N	M	M
154	0.15	G	G	N	N	M	M
184	0.18	G	G	N	N	M	M
224	0.22	G	G	N	N	M	M
274	0.27	G	G	N	N	M	M
334	0.33	G	G	N	N	M	M
394	0.39	G	G	N	N	M	M
474	0.47	G	G	N	N	M	M
684	0.68	G	G			M	M
824	0.82	G	G				
105	1	G	G				

Letter	A	C	E	G	J	K	M	N	P	Q	X	Y	Z
Max. Thickness	0.33 (0.013)	0.56 (0.022)	0.71 (0.028)	0.86 (0.034)	0.94 (0.037)	1.02 (0.040)	1.27 (0.050)	1.40 (0.055)	1.52 (0.060)	1.78 (0.070)	2.29 (0.090)	2.54 (0.100)	2.79 (0.110)

PAPER

EMBOSSED



= AEC-Q200 Qualified

= Under development (Contact factory for advanced samples)

X8R Dielectric



General Specifications

APPLICATIONS FOR X8R CAPACITORS

- All market sectors with a 150°C requirement
- Automotive on engine applications
- Oil exploration applications
- Hybrid automotive applications
 - Battery control
 - Inverter / converter circuits
 - Motor control applications
 - Water pump
- Hybrid commercial applications
 - Emergency circuits
 - Sensors
 - Temperature regulation

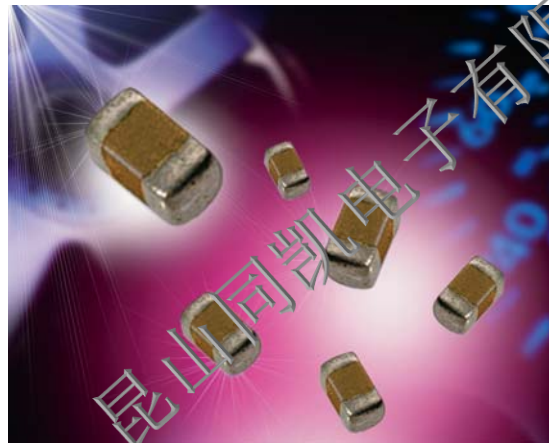
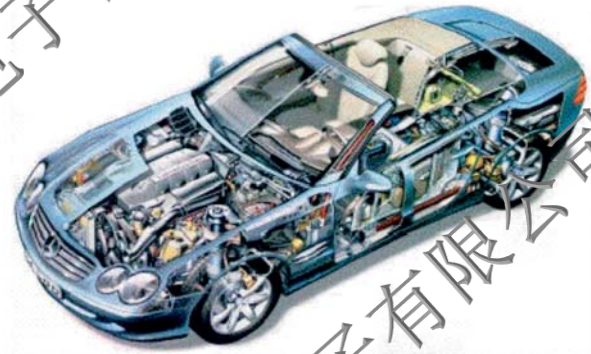

ADVANTAGES OF X8R MLC CAPACITORS

- Capacitance variation of $\pm 15\%$ between -55°C and $+150^{\circ}\text{C}$
- Qualified to the highest automotive AEC-Q200 standards
- Excellent reliability compared to other capacitor technologies
- RoHS compliant
- Low ESR / ESL compared to other technologies
- Tin solder finish
- FLEXITERM™ available
- Hybrid available
- 50V range available

ENGINEERING TOOLS FOR HIGH VOLTAGE MLC CAPACITORS

- Samples
- Technical Articles
- Application Engineering
- Application Support

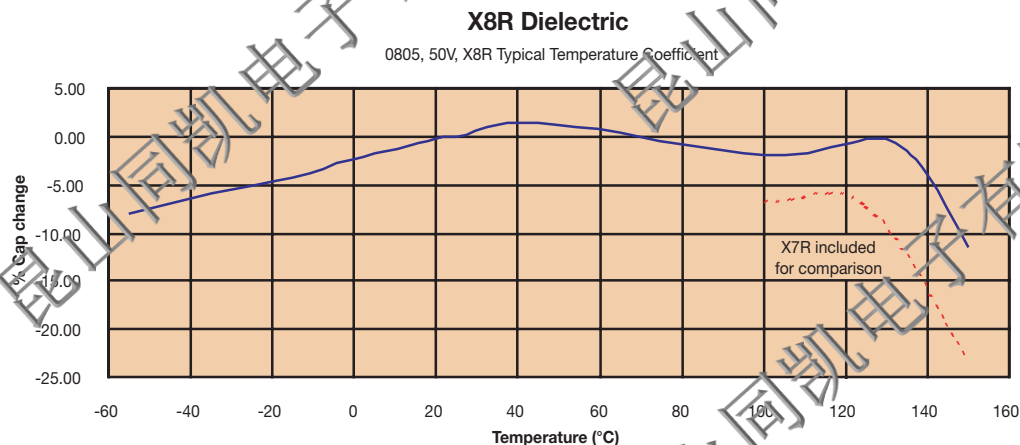

X7R Dielectric



General Specifications

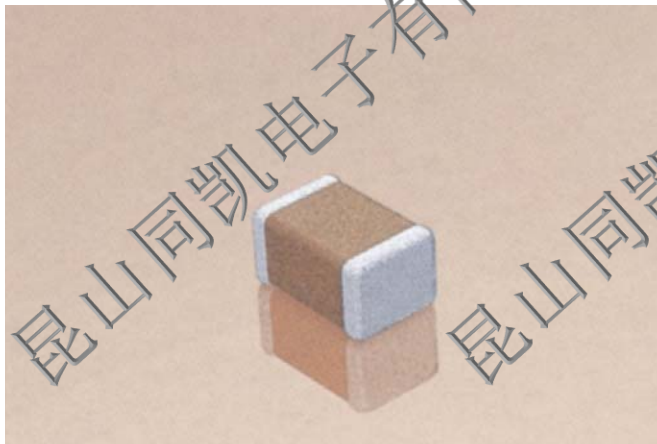

X7R formulations are called "temperature stable" ceramics and fall into EIA Class II materials. X7R is the most popular of these intermediate dielectric constant materials. Its temperature variation of capacitance is within $\pm 15\%$ from 55°C to $+125^\circ\text{C}$. This capacitance change is non-linear.

Capacitance for X7R varies under the influence of electrical operating conditions such as voltage and frequency.

X7R dielectric chip usage covers the broad spectrum of industrial applications where known changes in capacitance due to applied voltages are acceptable.

PART NUMBER (see page 2 for complete part number explanation)

0805	5	C	103	M	A	T	2	A
Size (L" x W")	Voltage 4V = 4 6.3V = 6 10V = Z 16V = Y 25V = 3 50V = 5 100V = 1 200V = 2 500V = 7	Dielectric X7R = C	Capacitance Code (In pF) 2 Sig. Digits + Number of Zeros	Capacitance Tolerance J = $\pm 5\%$ K = $\pm 10\%$ M = $\pm 20\%$	Failure Rate A = Not Applicable	Terminations T = Plated Ni and Sn 7 = Gold Plated* Z = FLEXITERM™**	Packaging 2 = 7" Reel 4 = 13" Reel 7 = Bulk Cass. 9 = Bulk	Special Code A = Std. Product
						*Optional termination		Contact Factory For Multiples
						**See FLEXITERM™ X7R section		

NOTE: Contact factory for availability of Termination and Tolerance Options for Specific Part Numbers.
Contact factory for non-specified capacitance values.

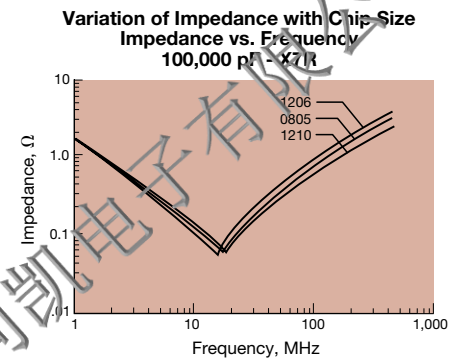
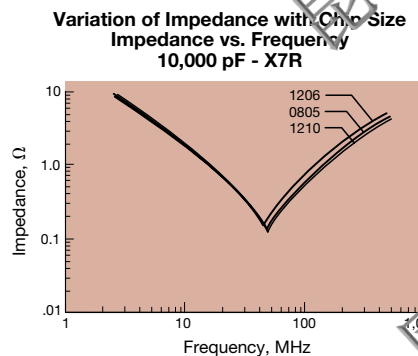
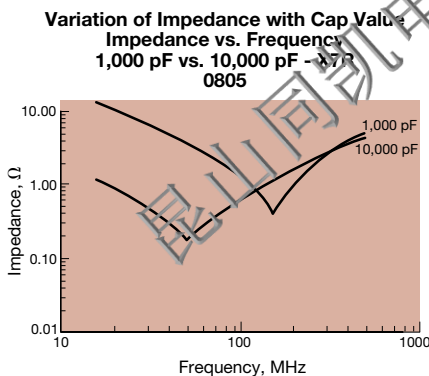
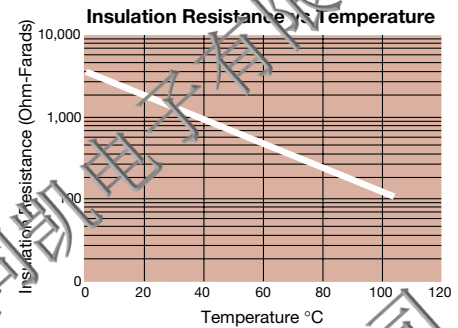
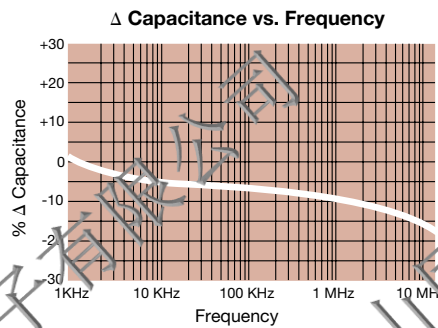
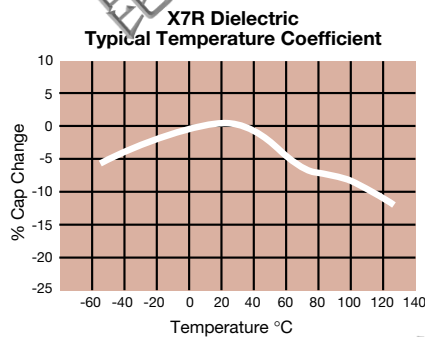

X7R Dielectric

Specifications and Test Methods

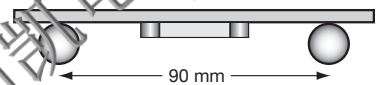

Parameter/Test		X7R Specification Limits	Measuring Conditions	
Operating Temperature Range		-55°C to +125°C	Temperature Cycle Chamber	
Capacitance		Within specified tolerance	Freq.: 1.0 kHz \pm 10% Voltage: 1.0Vrms \pm .2V For Cap > 10 μ F, 0.5Vrms @ 120Hz	
Dissipation Factor		\leq 2.5% for \geq 50V DC rating \leq 3.0% for 25V DC rating \leq 3.5% for 16V DC rating \leq 5.0% for \leq 10V DC rating		
Insulation Resistance		100,000M Ω or 1000M Ω - μ F, whichever is less	Charge device with rated voltage for 120 \pm 5 secs @ room temp/humidity	
Dielectric Strength		No breakdown or visual defects	Charge device with 300% of rated voltage for 1-5 seconds, w/charge and discharge current limited to 50 mA (max) Note: Charge device with 150% of rated voltage for 500V devices.	
Resistance to Flexure Stresses	Appearance	No defects	Deflection: 2mm Test Time: 30 seconds 1mm/sec  90 mm	
	Capacitance Variation	\leq \pm 12%		
	Dissipation Factor	Meets Initial Values (As Above)		
	Insulation Resistance	\geq Initial Value x 0.3		
Solderability		\geq 95% of each terminal should be covered with fresh solder	Dip device in eutectic solder at 230 \pm 5°C for 5.0 \pm 0.5 seconds	
Resistance to Solder Heat	Appearance	No defects, \geq 25% leaching of either end terminal	Dip device in eutectic solder at 260°C for 60 seconds. Store at room temperature for 24 \pm 2 hours before measuring electrical properties.	
	Capacitance Variation	\leq \pm 7.5%		
	Dissipation Factor	Meets Initial Values (As Above)		
	Insulation Resistance	Meets Initial Values (As Above)		
	Dielectric Strength	Meets Initial Values (As Above)		
Thermal Shock	Appearance	No visual defects	Step 1: -55°C \pm 2°	30 \pm 3 minutes
	Capacitance Variation	\leq \pm 7.5%	Step 2: Room Temp	\leq 3 minutes
	Dissipation Factor	Meets Initial Values (As Above)	Step 3: +125°C \pm 2°	30 \pm 3 minutes
	Insulation Resistance	Meets Initial Values (As Above)	Step 4: Room Temp	\leq 3 minutes
	Dielectric Strength	Meets Initial Values (As Above)	Repeat for 5 cycles and measure after 24 \pm 2 hours at room temperature	
Load Life	Appearance	No visual defects	Charge device with 1.5 rated voltage (\leq 10V) in test chamber set at 125°C \pm 2°C for 1000 hours (+48, -0) Remove from test chamber and stabilize at room temperature for 24 \pm 2 hours before measuring.	
	Capacitance Variation	\leq \pm 12.5%		
	Dissipation Factor	\leq Initial Value x 2.0 (See Above)		
	Insulation Resistance	\geq Initial Value x 0.3 (See Above)		
	Dielectric Strength	Meets Initial Values (As Above)		
Load Humidity	Appearance	No visual defects	Store in a test chamber set at 85°C \pm 2°C/ 85% \pm 5% relative humidity for 1000 hours (+48, -0) with rated voltage applied. Remove from chamber and stabilize at room temperature and humidity for 24 \pm 2 hours before measuring.	
	Capacitance Variation	\leq \pm 12.5%		
	Dissipation Factor	\leq Initial Value x 2.0 (See Above)		
	Insulation Resistance	\geq Initial Value x 0.3 (See Above)		
	Dielectric Strength	Meets Initial Values (As Above)		

X7R Dielectric

Capacitance Range



PREFERRED SIZES ARE SHADED

SIZE	0201		0402			0603				0805				1206				
Soldering	Reflow Only		Reflow Only			Reflow Only				Reflow/Wave				Reflow/Wave				
Packaging	All Paper		All Paper			All Paper				Paper/Embossed				Paper/Embossed				
(L) Length	MM (in.)	0.60 ± 0.03 (0.024 ± 0.001)	1.00 ± 0.10 (0.040 ± 0.004)			1.60 ± 0.15 (0.063 ± 0.006)				2.01 ± 0.20 (0.079 ± 0.008)				3.20 ± 0.20 (0.126 ± 0.008)				
(W) Width	MM (in.)	0.9 ± 0.03 (0.011 ± 0.001)	0.50 ± 0.10 (0.020 ± 0.004)			0.81 ± 0.05 (0.032 ± 0.003)				1.25 ± 0.20 (0.049 ± 0.008)				1.60 ± 0.20 (0.063 ± 0.008)				
(t) Terminal	MM (in.)	0.15 ± 0.05 (0.006 ± 0.002)	0.25 ± 0.15 (0.010 ± 0.006)			0.35 ± 0.15 (0.014 ± 0.006)				0.50 ± 0.25 (0.020 ± 0.010)				0.50 ± 0.25 (0.020 ± 0.010)				
WVDC		10 16	16 25 50	6.3 10 16	16 25 50 100 200	6.3 10 16 25 50 100 200	6.3 10 16 25 50 100 200	6.3 10 16 25 50 100 200	6.3 10 16 25 50 100 200	6.3 10 16 25 50 100 200	6.3 10 16 25 50 100 200	6.3 10 16 25 50 100 200	6.3 10 16 25 50 100 200	6.3 10 16 25 50 100 200	6.3 10 16 25 50 100 200			
Cap (pF)	100	A A																
	150	A A																
	220	A A			C													
	330	A A			C			G	G	G	J	J	J	J	J	J		
	470	A A			C			G	G	G	J	J	J	J	J	J		
	680	A A			C			G	G	G	J	J	J	J	J	J		
	1000	A A	A		C			G	G	G	J	J	J	J	J	J		
	1500	A			C			G	G	G	J	J	J	J	J	J		
	2200	A			C			G	G	G	J	J	J	J	J	J		
	3300	A			C			G	G	G	J	J	J	J	J	J		
	4700	A			C			G	G	G	J	J	J	J	J	J		
	6800	A			C			G	G	G	J	J	J	J	J	J		
Cap (µF)	0.010	A		C	C			G	G	G	J	J	J	J	J	J		
	0.015			C	C			G	G	G	J	J	J	J	J	J		
	0.022			C	C			G	G	G	J	J	J	J	J	J		
	0.033							G	G	G	J	J	J	J	J	J		
	0.047							G	G	G	J	J	J	J	J	J		
	0.068							G	G	G	J	J	J	J	J	J		
	0.10							G	G	G	J	J	J	J	J	J		
	0.15							G	G	G	J	J	J	J	J	J		
	0.22							G	G	G	J	J	J	J	J	J		
	0.33										N	N	N	N	N	N		
	0.47										N	N	N	N	N	N		
	0.68										N	N	N	N	N	N		
	1.0							J	J		N	N	N	N	N	N		
	1.5										N	N	N	N	N	N		
	2.2							J			N	N	N	N	N	N		
	3.3										N	N	N	N	N	N		
	4.7										P	P						
	10										P	P						
	22																	
	47																	
	100																	
WVDC		10 16	16 25 50	6.3 10 16	16 25 50 100 200	6.3 10 16 25 50 100 200	6.3 10 16 25 50 100 200	6.3 10 16 25 50 100 200	6.3 10 16 25 50 100 200	6.3 10 16 25 50 100 200	6.3 10 16 25 50 100 200	6.3 10 16 25 50 100 200	6.3 10 16 25 50 100 200	6.3 10 16 25 50 100 200	6.3 10 16 25 50 100 200			

Letter	A	C	E	G	J	K	M	N	P	Q	X	Y	Z
Max. Thickness	0.33 (0.013)	0.56 (0.022)	0.71 (0.028)	0.86 (0.034)	0.94 (0.037)	1.02 (0.040)	1.27 (0.050)	1.40 (0.055)	1.52 (0.060)	1.78 (0.070)	2.29 (0.090)	2.5 (0.100)	2.79 (0.110)
	PAPER					EMBOSSED							

= Under Development

X7S Dielectric



General Specifications

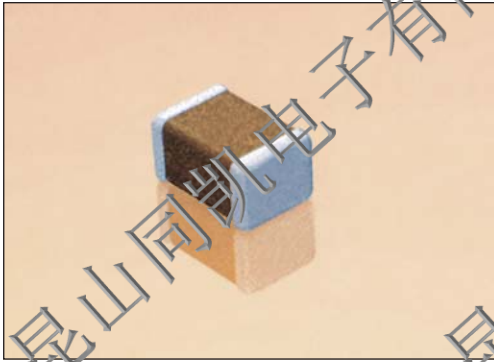

GENERAL DESCRIPTION

X7S formulations are called “temperature stable” ceramics and fall into EIA Class II materials. Its temperature variation of capacitance is within $\pm 22\%$ from -55°C to $+125^{\circ}\text{C}$. This capacitance change is non-linear.

Capacitance for X7S varies under the influence of electrical operating conditions such as voltage and frequency.

X7S dielectric chip usage covers the broad spectrum of industrial applications where known changes in capacitance due to applied voltages are acceptable.

PART NUMBER (see page 2 for complete part number explanation)

1206

Size
(L" x W")

Z

Voltage
4 = 4V
6 = 6.3V
Z = 10V
Y = 16V
3 = 25V
5 = 50V
1 = 100V
2 = 200V

Z

Dielectric
Z = X7S

105

Capacitance Code (10 pF)
2 Sig. Digits + Number of Zeros

M

Capacitance Tolerance
K = $\pm 10\%$
M = $\pm 20\%$

A

Failure Rate
A = N7

T

Terminations
T = Plated Ni and Sn

2

Packaging
2 = 7" Reel
4 = 13" Reel
7 = Bulk Cass.

A

Special Code
A = Std. Product

NOTE: Contact factory for availability of Tolerance Options for Specific Part Numbers.

TYPICAL ELECTRICAL CHARACTERISTICS

X7S Dielectric Typical Temperature Coefficient

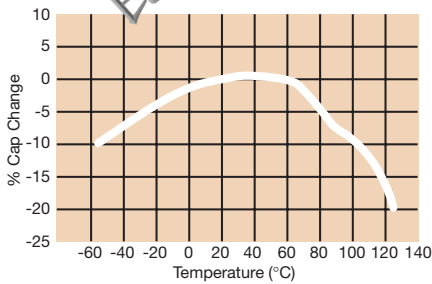

Δ Capacitance vs. Frequency

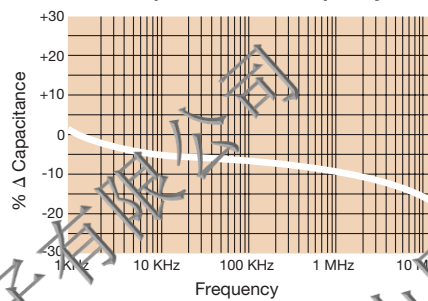

Insulation Resistance vs Temperature

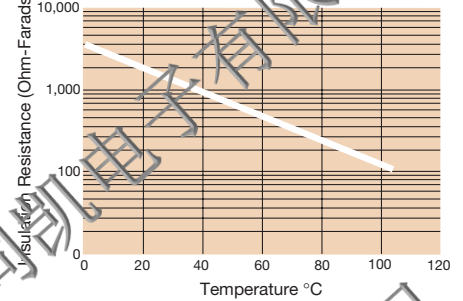

Variation of Impedance with Cap Value Impedance vs. Frequency 1,000 pF vs. 10,000 pF - X7S 0805

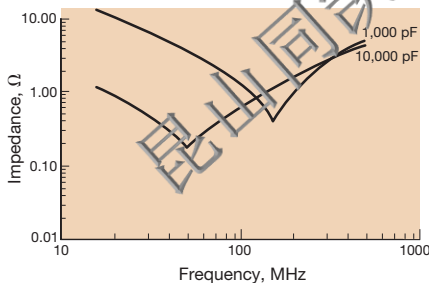

Variation of Impedance with Chip Size Impedance vs. Frequency 10,000 pF - X7S

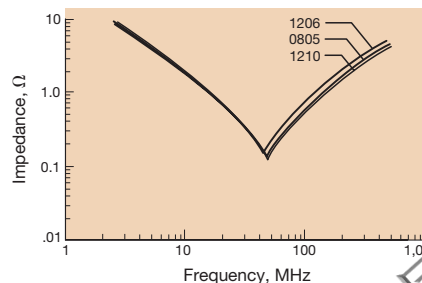

Variation of Impedance with Chip Size Impedance vs. Frequency 100,000 pF - X7S

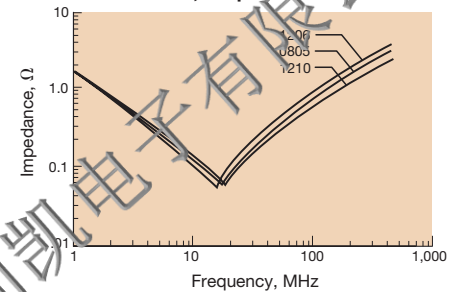

X7S Dielectric

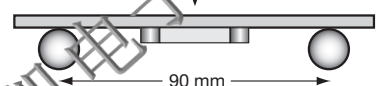

Specifications and Test Methods

Parameter/Test		X7S Specification Limits	Measuring Conditions	
Operating Temperature Range		-55°C to +125°C	Temperature Cycle Chamber	
Capacitance		Within specified tolerance	Freq.: 1.0 kHz \pm 10% Voltage: 1.0Vrms \pm .2V For Cap > 10 μ F, 0.5Vrms @ 120Hz	
Dissipation Factor		\leq 2.5% for \geq 50V DC rating \leq 3.0% for 25V DC rating \leq 3.5% for 16V DC rating \leq 5.0% for \leq 10V DC rating		
Insulation Resistance		100,000M Ω or 1000M Ω - μ F, whichever is less	Charge device with rated voltage for 120 \pm 5 secs @ room temp/humidity	
Dielectric Strength		No breakdown or visual defects	Charge device with 300% of rated voltage for 1-5 seconds, w/charge and discharge current limited to 50 mA (max)	
Resistance to Flexure Stresses	Appearance	No defects	Deflection: 2mm Test Time: 30 seconds 1mm/sec 	
	Capacitance Variation	\leq \pm 12%		
	Dissipation Factor	Meets Initial Values (As Above)		
	Insulation Resistance	\geq Initial Value \times 0.3		
Solderability		\geq 95% of each terminal should be covered with fresh solder	Dip device in eutectic solder at 230 \pm 5°C for 5.0 \pm 0.5 seconds	
Resistance to Solder Heat	Appearance	No defects, \geq 2% leaching of either end terminal	Dip device in eutectic solder at 260°C for 60 seconds. Store at room temperature for 24 \pm 2 hours before measuring electrical properties.	
	Capacitance Variation	\leq \pm 7.5%		
	Dissipation Factor	Meets Initial Values (As Above)		
	Insulation Resistance	Meets Initial Values (As Above)		
	Dielectric Strength	Meets Initial Values (As Above)		
Thermal Shock	Appearance	No visual defects	Step 1: -55°C \pm 2°	30 \pm 3 minutes
	Capacitance Variation	\leq \pm 7.5%	Step 2: Room Temp	\leq 3 minutes
	Dissipation Factor	Meets Initial Values (As Above)	Step 3: +125°C \pm 2°	30 \pm 3 minutes
	Insulation Resistance	Meets Initial Values (As Above)	Step 4: Room Temp	\leq 3 minutes
	Dielectric Strength	Meets Initial Values (As Above)	Repeat for 5 cycles and measure after 24 \pm 2 hours at room temperature	
	Load Life		No visual defects	Charge device with 1.5 rated voltage (\leq 10V) in test chamber set at 125°C \pm 2°C for 1000 hours (+48, -0)
Load Humidity	Appearance	No visual defects	Remove from test chamber and stabilize at room temperature for 24 \pm 2 hours before measuring. Store in a test chamber set at 80°C \pm 2°C/ 85% \pm 5% relative humidity for 1000 hours (+48, -0) with rated voltage applied. Remove from chamber and stabilize at room temperature and humidity for 24 \pm 2 hours before measuring.	
	Capacitance Variation	\leq \pm 12.5%		
	Dissipation Factor	\leq Initial Value \times 2.0 (See Above)		
	Insulation Resistance	\geq Initial Value \times 0.3 (See Above)		
	Dielectric Strength	Meets Initial Values (As Above)		

X7S Dielectric

Capacitance Range



PREFERRED SIZES ARE SHADED

SIZE	0402	0603	0805	1206	1210
Soldering	Reflow Only	Reflow Only	Reflow/Wave	Reflow/Wave	Reflow Only
Packaging	All Paper	All Paper	Paper/Embossed	Paper/Embossed	Paper/Embossed
(L) Length	MM (in.) 0.90 ± 0.10 (0.040 ± 0.004)	1.60 ± 0.15 (0.063 ± 0.006)	2.01 ± 0.20 (0.079 ± 0.008)	3.20 ± 0.20 (0.126 ± 0.008)	3.20 ± 0.20 (0.126 ± 0.008)
(W) Width	MM (in.) 0.50 ± 0.10 (0.020 ± 0.004)	0.81 ± 0.15 (0.032 ± 0.006)	1.25 ± 0.20 (0.049 ± 0.008)	1.60 ± 0.20 (0.063 ± 0.008)	2.50 ± 0.20 (0.098 ± 0.008)
(t) Terminal	MM (in.) 0.25 ± 0.15 (0.010 ± 0.006)	0.35 ± 0.15 (0.014 ± 0.006)	0.50 ± 0.25 (0.020 ± 0.010)	0.50 ± 0.25 (0.020 ± 0.010)	0.50 ± 0.25 (0.020 ± 0.010)
WVDC	6.3	6.3	25	4	6.3
Cap (pF)	100				
	150				
	220				
	330				
	470				
	680				
	1000				
	1500				
	2200				
	3300				
	4700				
	6800				
Cap (µF)	0.010				
	0.015				
	0.022				
	0.033	C			
	0.047	C			
	0.068	C			
	0.10	C			
	0.15				
	0.22		G		
	0.33		G		
	0.47		G		
	0.68		G		
	1.0		G		
	1.5			N	Q
	2.2			N	Q
	3.3			N	Q
	4.7			N	Q
	10				Q
	22				
	47				Z
	100				
WVDC	6.3	6.3	25	4	6.3

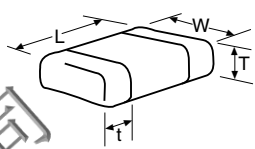

Letter	A	C	E	G	J	K	M	N	P	Q	X	Y	Z
Max. Thickness	0.33 (0.013)	0.56 (0.022)	0.71 (0.028)	0.86 (0.034)	0.94 (0.037)	1.02 (0.040)	1.27 (0.050)	1.40 (0.055)	1.52 (0.060)	1.78 (0.070)	2.29 (0.090)	2.54 (0.100)	2.79 (0.110)

PAPER

EMBOSSED

X5R Dielectric



General Specifications

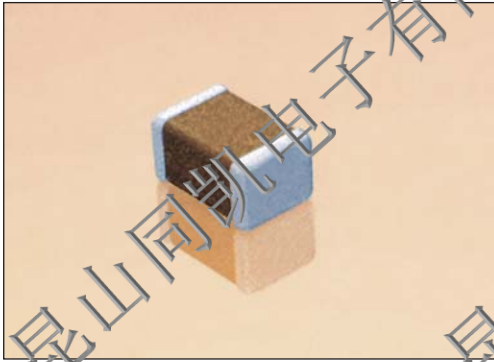

GENERAL DESCRIPTION

- General Purpose Dielectric for Ceramic Capacitors
- EIA Class II Dielectric
- Temperature variation of capacitance is within $\pm 15\%$ from -55°C to $+85^{\circ}\text{C}$
- Well suited for decoupling and filtering applications
- Available in High Capacitance values (up to $100\mu\text{F}$)

PART NUMBER (see page 2 for complete part number explanation)

1210

Size
(L" x W")

4

Voltage
4 = 4V
6 = 6.3V
Z = 10V
Y = 16V
3 = 25V
D = 35V
5 = 50V

D

Dielectric
D = X5R

107

Capacitance Code (in pF)
2 Sig. Digits + Number of Zeros

M

Capacitance Tolerance
K = $\pm 10\%$
M = $\pm 20\%$

A

Failure Rate
A = N7

T

Terminations
T = Plated Ni and Sn

2

Packaging
2 = 7" Reel
4 = 13" Reel
7 = Bulk Cass.
9 = Bulk

A

Special Code
A = Std.

NOTE: Contact factory for availability of Tolerance Options for Specific Part Numbers.
Contact factory for high specified capacitance values.

TYPICAL ELECTRICAL CHARACTERISTICS

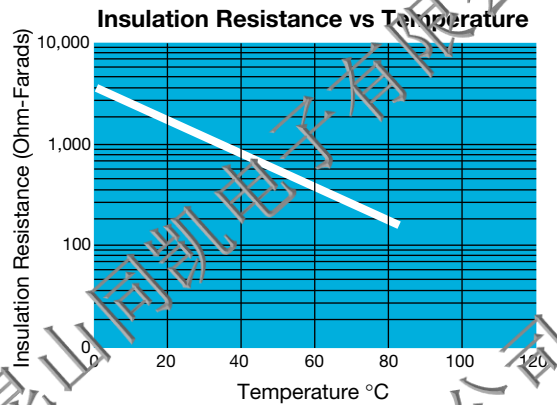
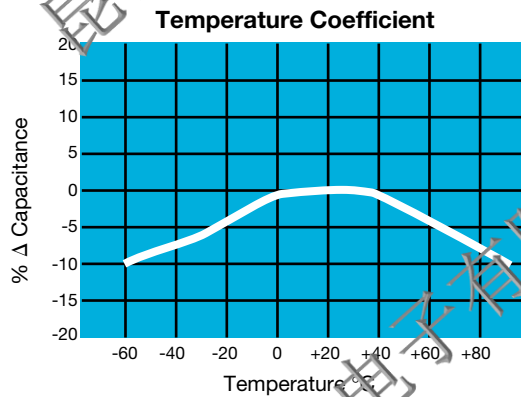

X5R Dielectric

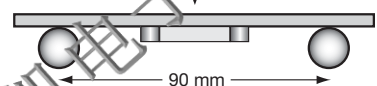

Specifications and Test Methods

Parameter/Test		X5R Specification Limits	Measuring Conditions	
Operating Temperature Range		-55°C to +85°C	Temperature Cycle Chamber	
Capacitance		Within specified tolerance	Freq.: 1.0 kHz ± 10% Voltage: 1.0Vrms ± .2V For Cap > 10 µF, 0.5Vrms @ 120Hz	
Dissipation Factor		≤ 2.5% for ≥ 50V DC rating ≤ 3.0% for 25V DC rating ≤ 3.5% for 16V DC rating ≤ 5.0% for ≤ 10V DC rating		
Insulation Resistance		100,000MΩ or 500MΩ - µF, whichever is less	Charge device with rated voltage for 120 ± 5 secs @ room temp/humidity	
Dielectric Strength		No breakdown or visual defects	Charge device with 300% of rated voltage for 1-5 seconds, w/charge and discharge current limited to 50 mA (max)	
Resistance to Flexure Stresses	Appearance	No defects	Deflection: 2mm Test Time: 30 seconds 1mm/sec 	
	Capacitance Variation	≤ ±12%		
	Dissipation Factor	Meets Initial Values (As Above)		
	Insulation Resistance	≥ Initial Value x 0.3		
Solderability		≥ 95% of each terminal should be covered with fresh solder	Dip device in eutectic solder at 230 ± 5°C for 5.0 ± 0.5 seconds	
Resistance to Solder Heat	Appearance	No defects, ≤ 2% leaching of either end terminal	Dip device in eutectic solder at 260°C for 60 seconds. Store at room temperature for 24 ± 2 hours before measuring electrical properties.	
	Capacitance Variation	≤ ±7.5%		
	Dissipation Factor	Meets Initial Values (As Above)		
	Insulation Resistance	Meets Initial Values (As Above)		
	Dielectric Strength	Meets Initial Values (As Above)		
Thermal Shock	Appearance	No visual defects	Step 1: -55°C ± 2°	30 ± 3 minutes
	Capacitance Variation	≤ ±7.5%	Step 2: Room Temp	≤ 3 minutes
	Dissipation Factor	Meets Initial Values (As Above)	Step 3: +85°C ± 2°	30 ± 3 minutes
	Insulation Resistance	Meets Initial Values (As Above)	Step 4: Room Temp	≤ 3 minutes
	Dielectric Strength	Meets Initial Values (As Above)	Repeat for 5 cycles and measure after 24 ± 2 hours at room temperature	
			Repeat for 5 cycles and measure after 24 ± 2 hours at room temperature	
Load Life	Appearance	No visual defects	Charge device with 1.5X rated voltage in test chamber set at 85°C ± 2°C for 1000 hours (+48, -0). Note: Contact factory for specific high CV devices that are tested at 1.5X rated voltage. Remove from test chamber and stabilize at room temperature for 24 ± 2 hours before measuring.	
	Capacitance Variation	≤ ±12.5%		
	Dissipation Factor	≤ Initial Value x 2.0 (See Above)		
	Insulation Resistance	≥ Initial Value x 0.3 (See Above)		
	Dielectric Strength	Meets Initial Values (As Above)		
Load Humidity	Appearance	No visual defects	Store in a test chamber set at 85°C ± 2°C/ 85% ± 5% relative humidity for 1000 hours (+48, -0) with rated voltage applied. Remove from chamber and stabilize at room temperature and humidity for 24 ± 2 hours before measuring.	
	Capacitance Variation	≤ ±12.5%		
	Dissipation Factor	≤ Initial Value x 2.0 (See Above)		
	Insulation Resistance	≥ Initial Value x 0.3 (See Above)		
	Dielectric Strength	Meets Initial Values (As Above)		

Y5V Dielectric



General Specifications

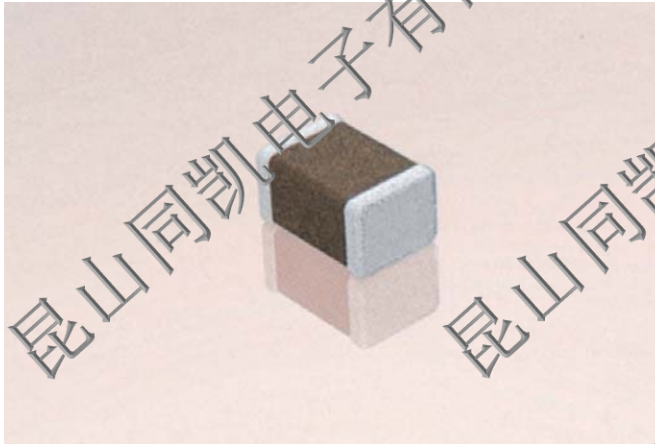

Y5V formulations are for general-purpose use in a limited temperature range. They have a wide temperature characteristic of $\pm 22\%$ – 82% capacitance change over the operating temperature range of -30°C to $+85^{\circ}\text{C}$.

These characteristics make Y5V ideal for decoupling applications within limited temperature range.

PART NUMBER (see page 2 for complete part number explanation)

0805

Size
(L" x W")

3

Voltage
6.3V = 6
10V = Z
16V = Y
25V = 3
50V = 5

G

Dielectric
Y5V \pm G

104

Capacitance Code (In pF)
2 Sig. Digits + Number of Zeros

Z

Capacitance Tolerance
Z = $+80$ – 20%

A

Failure Rate
A = Not Applicable

T

Terminations
T = Plated Ni and Sn

2

Packaging
2 = 7" Reel
4 = 13" Reel

A

Special Code
A = Std. Product

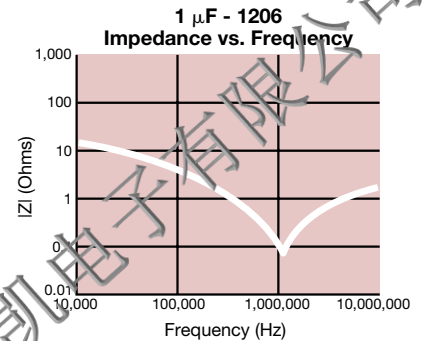
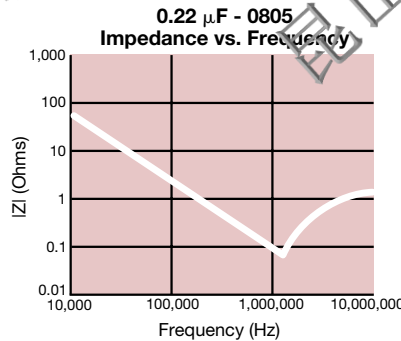
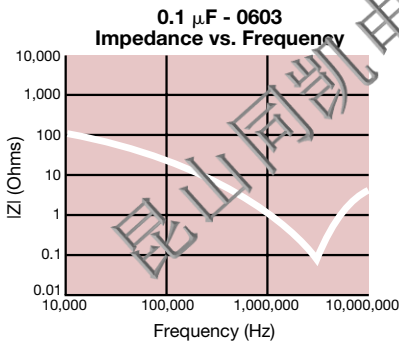
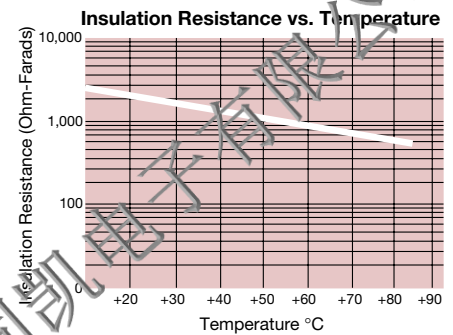
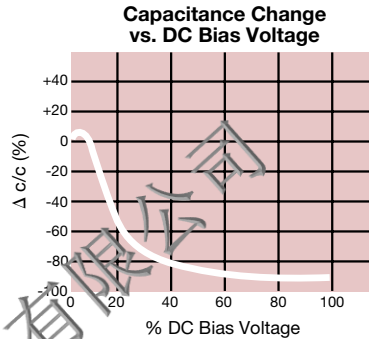
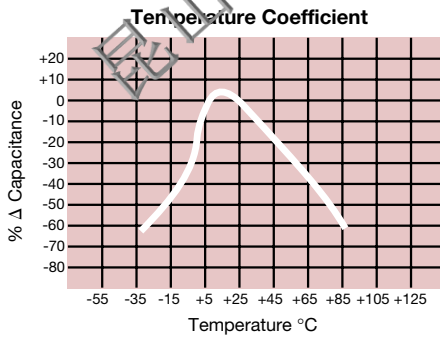

Y5V Dielectric

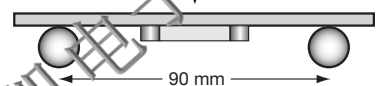

Specifications and Test Methods

Parameter/Test		Y5V Specification Limits	Measuring Conditions	
Operating Temperature Range		-30°C to +85°C	Temperature Cycle Chamber	
Capacitance		Within specified tolerance		
Dissipation Factor		$\leq 5.0\%$ for $\geq 50V$ DC rating $\leq 7.0\%$ for 25V DC rating $\leq 9.0\%$ for 16V DC rating $\leq 12.5\%$ for $\leq 10V$ DC rating	Freq.: 1.0 kHz $\pm 10\%$ Voltage: 1.0Vrms $\pm .2V$ For Cap > 10 μF , 0.5Vrms @ 120Hz	
Insulation Resistance		100,000M Ω or 500M Ω - μF , whichever is less	Charge device with rated voltage for 120 ± 5 secs @ room temp/humidity	
Dielectric Strength		No breakdown or visual defects	Charge device with 300% of rated voltage for 1-5 seconds, w/charge and discharge current limited to 50 mA (max)	
Resistance to Flexure Stresses	Appearance	No defects	Deflection: 2mm Test Time: 30 seconds 1mm/sec 	
	Capacitance Variation	$\leq \pm 30\%$		
	Dissipation Factor	Meets Initial Values (As Above)		
	Insulation Resistance	\geq Initial Value $\times 0.1$		
Solderability		$\geq 95\%$ of each terminal should be covered with fresh solder	Dip device in eutectic solder at 230 $\pm 5^\circ C$ for 5.0 ± 0.5 seconds	
Resistance to Solder Heat	Appearance	No defects, $\leq 2\%$ leaching of either end terminal	Dip device in eutectic solder at 260°C for 60 seconds. Store at room temperature for 24 ± 2 hours before measuring electrical properties.	
	Capacitance Variation	$\leq \pm 20\%$		
	Dissipation Factor	Meets Initial Values (As Above)		
	Insulation Resistance	Meets Initial Values (As Above)		
	Dielectric Strength	Meets Initial Values (As Above)		
Thermal Shock	Appearance	No visual defects	Step 1: -30°C $\pm 2^\circ$	30 ± 3 minutes
	Capacitance Variation	$\leq \pm 20\%$	Step 2: Room Temp	≤ 3 minutes
	Dissipation Factor	Meets Initial Values (As Above)	Step 3: +85°C $\pm 2^\circ$	30 ± 3 minutes
	Insulation Resistance	Meets Initial Values (As Above)	Step 4: Room Temp	≤ 3 minutes
	Dielectric Strength	Meets Initial Values (As Above)	Repeat for 5 cycles and measure after 24 ± 2 hours at room temperature	
	Appearance	No visual defects		
Load Life	Capacitance Variation	$\leq \pm 30\%$	Charge device with twice rated voltage in test chamber set at 85°C $\pm 2^\circ C$ for 1000 hours (+48, -0) Remove from test chamber and stabilize at room temperature for 24 ± 2 hours before measuring.	
	Dissipation Factor	\leq Initial Value $\times 1.5$ (See Above)		
	Insulation Resistance	\geq Initial Value $\times 0.1$ (See Above)		
	Dielectric Strength	Meets Initial Values (As Above)		
	Appearance	No visual defects		
Load Humidity	Capacitance Variation	$\leq \pm 30\%$	Store in a test chamber set at 85°C $\pm 2^\circ C$ / 85% $\pm 5\%$ relative humidity for 1000 hours (+48, -0) with rated voltage applied. Remove from chamber and stabilize at room temperature and humidity for 24 ± 2 hours before measuring.	
	Dissipation Factor	\leq Initial Value $\times 1.5$ (See above)		
	Insulation Resistance	\geq Initial Value $\times 0.1$ (See Above)		
	Dielectric Strength	Meets Initial Values (As Above)		
	Appearance	No visual defects		

MLCC Tin/Lead Termination "B"



General Specifications

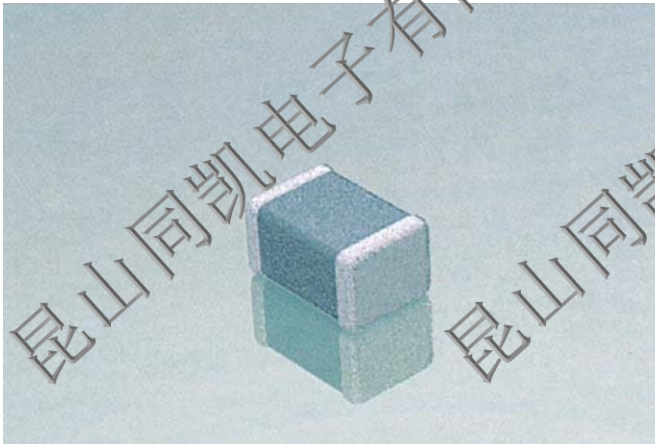

AVX Corporation will support those customers for commercial and military Multilayer Ceramic Capacitors with a termination consisting of 5% minimum lead. This termination is indicated by the use of a "B" in the 12th position of the AVX Catalog Part Number. This fulfills AVX's commitment to providing a full range of products to our customers. AVX has provided in the following pages a full range of values that we are currently offering in this special "B" termination. Please contact the factory if you require additional information on our MLCC Tin/Lead Termination "B" products.

PART NUMBER (see page 2 for complete part number explanation)

LD05	5	A	101	J	A	B	2	A
Size	Voltage	Dielectric	Capacitance Code (In pF)	Capacitance Tolerance	Failure Rate	Terminations	Packaging	Special Code
LD02 - 0402 LD03 - 0603 LD04 - 0504* LD05 - 0805 LD06 - 1206 LD10 - 1210 LD12 - 1812 LD13 - 1825 LD14 - 2225	6.3V = 6 10V = Z 16V = Y 25V = 3 50V = 5 100V = 1 200V = 2 500V = 7	COG (NPO) = A X7R = C X5R = D X8R = F	2 Sig. Digits + Number of Zeros	B = ±.10 pF (<10pF) C = ±.25 pF (<10pF) D = ±.50 pF (<10pF) F = ±1% (≥ 10 pF) G = ±2% (≥ 10 pF) J = ±5% K = ±10% M = ±20%	A = Not Applicable	B = 5% min lead X = FLEXITERM™ with 5% min lead	2 = 7" Reel 4 = 13" Reel 7 = Bulk Cass. 9 = Bulk	A = Std. Product
							Contact Factory For Multiples	

*LD04 has the same CV ranges as LD03.

NOTE: Contact factory for availability of Tolerance Options for Specific Part Numbers.
Contact factory for non-specific capacitance values.

See FLEXITERM™ section
for CV options

NP0	Refer to page 4 for Electrical Graphs
X7R	Refer to page 14 for Electrical Graphs
X7S	Refer to page 18 for Electrical Graphs
X5R	Refer to page 21 for Electrical Graphs
Y5V	Refer to page 24 for Electrical Graphs

MLCC Tin/Lead Termination "B"



Capacitance Range (X8R Dielectric)

SIZE		LD03		LD05		LD06	
	WVDC	25V	50V	25V	50V	25V	50V
271	Cap	G	G				
331	(pF)	G	G	J	J		
471		G	G	J	J		
681		G	G	J	J		
102		G	G	J	J	J	J
152		G	G	J	J	J	J
182		G	G	J	J	J	J
222		G	G	J	J	J	J
272		G	G	J	J	J	J
332		G	G	J	J	J	J
392		G	G	J	J	J	J
472		G	G	J	J	J	J
562		G	G	J	J	J	J
682		G	G	J	J	J	J
822		G	G	J	J	J	J
103	Cap	G	G	J	J	J	J
123	(µF)	G	G	J	J	J	J
153		G	G	J	J	J	J
183		G	G	J	J	J	J
223		G	G	J	J	J	J
273		G	G	J	J	J	J
333		G	G	J	J	J	J
393		G	G	J	J	J	J
473		G	G	J	J	J	J
563		G		N	N	M	M
683		G		N	N	M	M
823				N	N	M	M
104	0.1			N	N	M	M
124	0.12			N	N	M	M
154	0.15			N	N	M	M
184	0.18			N	N	M	M
224	0.22			N	N	M	M
274	0.27					M	M
334	0.33					M	M
394	0.39					M	
474	0.47					M	
684	0.68						
824	0.82						
105	1						
SIZE	WVDC	25V	50V	25V	50V	25V	50V
		LD03		LD05		LD06	

Letter	A	C	E	G	J	K	M	N	P	Q	X	Y	Z
Max. Thickness	0.33 (0.013)	0.56 (0.022)	0.71 (0.028)	0.86 (0.034)	0.94 (0.037)	1.02 (0.040)	1.27 (0.050)	1.40 (0.055)	1.52 (0.060)	1.78 (0.070)	2.29 (0.090)	2.54 (0.100)	2.79 (0.110)
	PAPER					EMBOSSD							

MLCC Tin/Lead Termination "B"



Capacitance Range (NP0 Dielectric)

PREFERRED SIZES ARE SHADED

SIZE	LD02			LD03			LD05				LD06							
Soldering	Reflow Only			Reflow Only			Reflow/Wave				Reflow/Wave							
Packaging	A Paper			All Paper			Paper/Embossed				Paper/Embossed							
(L) Length	1.00 ± 0.10 (0.040 ± 0.004)			1.60 ± 0.15 (0.063 ± 0.006)			2.01 ± 0.20 (0.079 ± 0.008)				3.20 ± 0.20 (0.126 ± 0.008)							
(W) Width	0.50 ± 0.10 (0.020 ± 0.004)			0.81 ± 0.15 (0.032 ± 0.006)			1.25 ± 0.20 (0.049 ± 0.008)				1.60 ± 0.20 (0.063 ± 0.008)							
(t) Terminal	0.25 ± 0.15 (0.010 ± 0.006)			0.35 ± 0.15 (0.014 ± 0.006)			0.50 ± 0.25 (0.020 ± 0.010)				0.50 ± 0.25 (0.020 ± 0.010)							
WVDC	16	25	50	6.3	25	50	100	16	25	50	100	200	16	25	50	100	200	500
0.5	C	C	C	G	G	G	G	J	J	J	J	J	J	J	J	J	J	J
1.0	C	C	C	G	G	G	G	J	J	J	J	J	J	J	J	J	J	J
1.2	C	C	C	G	G	G	G	J	J	J	J	J	J	J	J	J	J	J
1.5	C	C	C	G	G	G	G	J	J	J	J	J	J	J	J	J	J	J
1.8	C	C	C	G	G	G	G	J	J	J	J	J	J	J	J	J	J	J
2.2	C	C	C	G	G	G	G	J	J	J	J	J	J	J	J	J	J	J
2.7	C	C	C	G	G	G	G	J	J	J	J	J	J	J	J	J	J	J
3.3	C	C	C	G	G	G	G	J	J	J	J	J	J	J	J	J	J	J
3.9	C	C	C	G	G	G	G	J	J	J	J	J	J	J	J	J	J	J
4.7	C	C	C	G	G	G	G	J	J	J	J	J	J	J	J	J	J	J
5.6	C	C	C	G	G	G	G	J	J	J	J	J	J	J	J	J	J	J
6.8	C	C	C	G	G	G	G	J	J	J	J	J	J	J	J	J	J	J
8.2	C	C	C	G	G	G	G	J	J	J	J	J	J	J	J	J	J	J
10	C	C	C	G	G	G	G	J	J	J	J	J	J	J	J	J	J	J
12	C	C	C	G	G	G	G	J	J	J	J	J	J	J	J	J	J	J
15	C	C	C	G	G	G	G	J	J	J	J	J	J	J	J	J	J	J
18	C	C	C	G	G	G	G	J	J	J	J	J	J	J	J	J	J	J
22	C	C	C	G	G	G	G	J	J	J	J	J	J	J	J	J	J	J
27	C	C	C	G	G	G	G	J	J	J	J	J	J	J	J	J	J	J
33	C	C	C	G	G	G	G	J	J	J	J	J	J	J	J	J	J	J
39	C	C	C	G	G	G	G	J	J	J	J	J	J	J	J	J	J	J
47	C	C	C	G	G	G	G	J	J	J	J	J	J	J	J	J	J	J
56	C	C	C	G	G	G	G	J	J	J	J	J	J	J	J	J	J	J
68	C	C	C	G	G	G	G	J	J	J	J	J	J	J	J	J	J	J
82	C	C	C	G	G	G	G	J	J	J	J	J	J	J	J	J	J	J
100	C	C	C	G	G	G	G	J	J	J	J	J	J	J	J	J	J	J
120	C	C	C	G	G	G	G	J	J	J	J	J	J	J	J	J	J	J
150	C	C	C	G	G	G	G	J	J	J	J	J	J	J	J	J	J	J
180	C	C	C	G	G	G	G	J	J	J	J	J	J	J	J	J	J	J
220	C	C	C	G	G	G	G	J	J	J	J	J	J	J	J	J	J	J
270				G	G	G	G	J	J	J	J	M	J	J	J	J	J	M
330				G	G	G	G	J	J	J	J	M	J	J	J	J	J	M
390				G	G	G	G	J	J	J	J	M	J	J	J	J	J	M
470				G	G	G	G	J	J	J	J	M	J	J	J	J	J	M
560				G	G	G	G	J	J	J	J	M	J	J	J	J	J	M
680				G	G	G	G	J	J	J	J		J	J	J	J	J	P
820				G	G	G	G	J	J	J	J		J	J	J	J	J	P
1000				G	G	G		J	J	J	J		J	J	J	J	J	Q
1200								J	J	J	J		J	J	J	J	J	Q
1500								J	J	J	J		J	J	J	J	J	Q
1800								J	J	J	J		J	J	M	M	M	
2200								J	J	J	J		J	J	M	M	M	
2700								J	J	M			J	J	M	M	M	
3300										J			J	J	M	M	M	
3900										J			J	J	M	M	M	
4700										J			J	J	M	M	M	
5600										J			J	J	M			
6800										M			M	M				
8200										M			M	M				
Cap (µF)										M			M	M				
0.010																		
0.012																		
0.015																		
0.018																		
0.022																		
0.027																		
0.033																		
0.039																		
0.047																		
0.068																		
0.082																		
0.1																		
WVDC	16	25	50	6.3	25	50	100	16	25	50	100	200	16	25	50	100	200	500
SIZE	LD02			LD03			LD05				LD06							
Letter	A	C	E	G	J	K	M	N	P	Q	X	Y	Z					
Max. Thickness	0.33 (0.013)	0.56 (0.022)	0.71 (0.028)	0.86 (0.034)	0.94 (0.037)	1.02 (0.040)	1.27 (0.050)	1.40 (0.055)	1.52 (0.060)	1.78 (0.070)	2.29 (0.090)	2.54 (0.100)	2.79 (0.110)					
	PAPER						EMBOSSED											

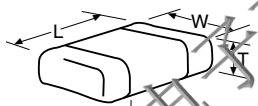

MLCC Tin/Lead Termination "B"



Capacitance Range (X7R Dielectric)

PREFERRED SIZES ARE SHADED

SIZE	LD02					LD03					LD05					LD06									
Soldering	Reflow Only					Reflow Only					Reflow/Wave					Reflow/Wave									
Packaging	All Paper					All Paper					Paper/Embossed					Paper/Embossed									
(L) Length	1.60 ± 0.10 (0.049 ± 0.004)					1.60 ± 0.15 (0.063 ± 0.006)					2.01 ± 0.20 (0.079 ± 0.008)					3.20 ± 0.20 (0.126 ± 0.008)									
(W) Width	1.50 ± 0.10 (0.020 ± 0.004)					0.81 ± 0.15 (0.032 ± 0.006)					1.25 ± 0.20 (0.049 ± 0.008)					1.60 ± 0.20 (0.063 ± 0.008)									
(t) Terminal	0.25 ± 0.15 (0.010 ± 0.006)					0.35 ± 0.15 (0.014 ± 0.006)					0.50 ± 0.25 (0.020 ± 0.010)					0.50 ± 0.25 (0.020 ± 0.010)									
WDC	16	25	50	6.3	10	16	25	50	100	200	6.3	10	16	25	50	100	200	6.3	10	16	25	50	100	200	500
Cap (pF)			C						G	G	G				J	J	J	J	J	J					K
			C						G	G	G				J	J	J	J	J	J					K
			C						G	G	G				J	J	J	J	J	J					K
			C						G	G	G				J	J	J	J	J	J					K
			C						G	G	G				J	J	J	J	J	J					M
			C						G	G	G				J	J	J	J	J	J					M
			C						G	G	G				J	J	J	J	J	J					M
			C						G	G	G				J	J	J	J	J	J					M
			C						G	G	G				J	J	J	J	J	J					M
			C						G	G	G				J	J	J	J	J	J					M
			C						G	G	G				J	J	J	J	J	J					M
			C						G	G	G				J	J	J	J	J	J					M
			C						G	G	G				J	J	J	J	J	J					M
			C						G	G	G				J	J	J	J	J	J					M
			C						G	G	G				J	J	J	J	J	J					M
			C						G	G	G				J	J	J	J	J	J					M
			C						G	G	G				J	J	J	J	J	J					M
			C						G	G	G				J	J	J	J	J	J					M
			C						G	G	G				J	J	J	J	J	J					M
			C						G	G	G				J	J	J	J	J	J					M
			C						G	G	G				J	J	J	J	J	J					M
			C						G	G	G				J	J	J	J	J	J					M
			C						G	G	G				J	J	J	J	J	J					M
			C						G	G	G				J	J	J	J	J	J					M
			C						G	G	G				J	J	J	J	J	J					M
			C						G	G	G				J	J	J	J	J	J					M
			C						G	G	G				J	J	J	J	J	J					M
			C						G	G	G				J	J	J	J	J	J					M
			C						G	G	G				J	J	J	J	J	J					M
			C						G	G	G				J	J	J	J	J	J					M
			C						G	G	G				J	J	J	J	J	J					M
			C						G	G	G				J	J	J	J	J	J					M
			C						G	G	G				J	J	J	J	J	J					M
			C						G	G	G				J	J	J	J	J	J					M
			C						G	G	G				J	J	J	J	J	J					M
			C						G	G	G				J	J	J	J	J	J					M
			C						G	G	G				J	J	J	J	J	J					M
			C						G	G	G				J	J	J	J	J	J					M
			C						G	G	G				J	J	J	J	J	J					M
			C						G	G	G				J	J	J	J	J	J					M
			C						G	G	G				J	J	J	J	J	J					M
			C						G	G	G				J	J	J	J	J	J					M
			C						G	G	G				J	J	J	J	J	J					M
			C						G	G	G				J	J	J	J	J	J					M
			C						G	G	G				J	J	J	J	J	J					M
			C						G	G	G				J	J	J	J	J	J					M
			C						G	G	G				J	J	J	J	J	J					M
			C						G	G	G				J	J	J	J	J	J					M
			C						G	G	G				J	J	J	J	J	J					M
			C						G	G	G				J	J	J	J	J	J					M
			C						G	G	G				J	J	J	J	J	J					M
			C						G	G	G				J	J	J	J	J	J					M
			C						G	G	G				J	J	J	J	J	J					M
			C						G	G	G				J	J	J	J	J	J					M
			C						G	G	G				J	J	J	J	J	J					M
			C						G	G	G				J	J	J	J	J	J					M
			C						G	G	G				J	J	J	J	J	J					M
			C						G	G	G				J	J	J	J	J	J					M
			C						G	G	G				J	J	J	J	J	J					M
			C						G	G	G				J	J	J	J	J	J					M
			C						G	G	G				J	J	J	J	J	J					M
			C						G	G	G				J	J	J	J	J	J					M
			C						G	G	G				J	J	J	J	J	J					M
			C						G	G	G				J	J	J	J	J	J					M
			C						G	G	G				J	J	J	J	J	J					M
			C						G	G	G				J	J	J	J	J	J					M
			C						G	G	G				J	J	J	J	J	J					M
			C						G	G	G				J	J	J	J	J	J					M
			C						G	G	G				J	J	J	J	J	J					M
			C						G	G	G				J	J	J	J	J	J					M
			C						G	G	G				J	J	J	J	J	J					M
			C						G	G	G				J	J	J	J	J	J					M
			C						G	G	G				J	J	J	J	J	J					M
			C						G	G	G				J	J	J	J	J	J					M
			C						G	G	G				J	J	J	J	J	J					M
			C						G	G	G				J	J	J	J	J	J					M
			C						G	G	G				J	J	J	J	J	J					M
			C						G	G	G				J	J	J	J	J	J					M
			C						G	G	G				J	J	J	J	J	J					M
			C						G	G	G				J	J	J	J	J	J					M
			C						G	G	G				J	J	J	J	J	J					M
			C						G	G	G				J	J	J	J	J	J					M
			C						G	G	G				J	J	J	J	J	J					M
			C						G	G	G				J	J	J	J	J	J					M
			C						G	G	G				J	J	J	J	J	J					M
			C						G	G	G				J	J	J	J	J	J					M
			C						G	G	G				J	J	J	J	J	J					M
			C						G	G	G				J	J	J	J	J	J					M
			C						G	G	G				J	J	J	J	J	J					M
			C						G	G	G				J	J	J	J	J	J					M
			C						G	G	G														

MLCC Tin/Lead Termination "B"



Capacitance Range (X7R Dielectric)

PREFERRED SIZES ARE SHADED

SIZE	LD10					LD12					LD13		LD14		
Soldering	Reflow Only										Reflow Only		Reflow Only		
Packaging	Paper/Embossed										All Embossed		All Embossed		
(L) Length	3.20 ± 0.20 (0.126 ± 0.008)					4.50 ± 0.30 (0.177 ± 0.012)					4.50 ± 0.30 (0.177 ± 0.012)		5.72 ± 0.25 (0.225 ± 0.010)		
(W) Width	2.50 ± 0.20 (0.098 ± 0.008)					3.20 ± 0.20 (0.126 ± 0.008)					6.40 ± 0.40 (0.252 ± 0.016)		6.35 ± 0.25 (0.250 ± 0.010)		
(t) Terminal	0.50 ± 0.25 (0.020 ± 0.010)					0.61 ± 0.36 (0.024 ± 0.014)					0.61 ± 0.36 (0.024 ± 0.014)		0.64 ± 0.39 (0.025 ± 0.015)		
WVDC	10	16	25	50	100	200	500	50	100	200	500	50	100	50	100
Cap (pF)															
100															
150															
220															
330															
470															
680															
1000															
1500	J	J	J	J	J	J	J	M							
2200	J	J	J	J	J	J	J	M							
3300	J	J	J	J	J	J	J	M							
4700	J	J	J	J	J	J	J	M							
6800	J	J	J	J	J	J	J	M							
Cap (µF)															
0.010	J	J	J	J	J	J	J	K	K	K	M	M	M	P	
0.015	J	J	J	J	J	J	J	P	K	K	P	M	M	M	P
0.022	J	J	J	J	J	J	J	Q	K	K	P	M	M	M	P
0.033	J	J	J	J	J	J	J	M	K	K	X	M	M	M	P
0.047	J	J	J	J	J	J	J	M	K	K	Z	M	M	M	P
0.068	J	J	J	J	J	J	J	M	K	K	K	M	M	M	P
0.10	J	J	J	J	J	J	J	M	K	K	K	M	M	M	P
0.15	J	J	J	J	J	M			K	K	P	M	M	M	P
0.22	J	J	J	J	J	P			K	K	P	M	M	M	P
0.33	J	J	J	J	J	Z			K	M		M	M	M	P
0.47	M	M	M	M	M	Z			K	P		M	M	M	P
0.68	M	M	M	X	Z	Z			M	Q		M	M	M	P
1.0	N	N	P	X	Z				M	X		M		M	P
1.5	N	N	Z	Z	Z				Z	Z		M		M	X
2.2	Z	Z	Z	Z	Z				Z	Z				M	
3.3	Z	Z	Z	Z	Z				Z						
4.7	Z	Z	Z	Z	Z				Z						
10	Z	Z	Z	Z	Z										
22	Z	Z													
47															
100															
WVDC	10	16	25	50	100	200	500	50	100	200	500	50	100	50	100

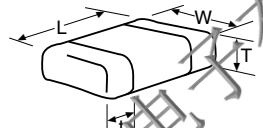

Letter	A	C	E	G	J	K	M	N	P	Q	X	Y	Z
Max. Thickness	0.33 (0.013)	0.56 (0.022)	0.71 (0.028)	0.86 (0.034)	0.94 (0.037)	1.02 (0.040)	1.27 (0.050)	1.40 (0.055)	1.52 (0.060)	1.78 (0.070)	2.29 (0.090)	2.54 (0.100)	2.79 (0.110)
	PAPER					EMBOSSSED							

 = Under Development



MLCC Low Profile



General Specifications

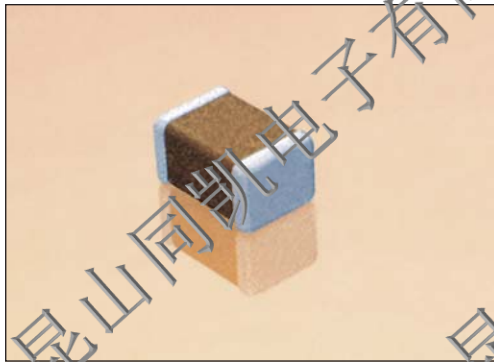

GENERAL DESCRIPTION

AVX introduces the LT series comprising a range of low profile products in our X5R dielectric. X5R is a Class II dielectric with temperature variation of capacitance within $\pm 15\%$ from -55°C to $+85^{\circ}\text{C}$. Offerings include 0402, 0603, 0805, and 1206 packages in compact, low profile designs. The LT series is ideal for decoupling and filtering applications where height clearance is limited.

PART NUMBER (see page 2 for complete part number explanation)

LT05	Z	D	475	K	M	T	2	S
Size	Voltage	Dielectric	Capacitance Code (in pF)	Capacitance Tolerance	Failure Rate	Terminations	Packaging	Special Code
LT02 - 0402 LT03 - 0603 LT05 - 0805 LT06 - 1206	4V = 4 6.3V = 6 10V = Z 16V = Y	X5R = D	2 Sig. Digits + Number of Zeros	K = $\pm 10\%$ M = $\pm 20\%$	A = Not Applicable	T = Plated Ni and Sn	2 = 7" Reel 4 = 13" Reel 7 = Bulk Cass. 9 = Bulk	CSXW See table below
							Contact Factory For Multiples	

CAPACITANCE RANGE (X5R DIELECTRIC)

SIZE	LT02	LT03			LT05		LT06
WVDC	4	4	6.3	16	6.3	10	16
Cap (µF)							
0.33							
0.47							
0.68							
1.0	C			S			
1.5							
2.2							
3.3							
4.7		S					
10					X	S X	X
22							W
47							
100							
WVDC	4		6.3	16	6.3	10	16
SIZE	LT02	LT03			LT05		LT06

Special Code Table

Letter	C	S	X	W
Max. Thickness	0.356 (0.014)	0.56 (0.022)	0.95 (0.038)	1.02 (0.040)
	PAPER			



Automotive MLCC

Automotive



GENERAL DESCRIPTION

AVX Corporation has supported the Automotive Industry requirements for Multilayer Ceramic Capacitors consistently for more than 10 years. Products have been developed and tested specifically for automotive applications and all manufacturing facilities are QS9000 and VDA 6.4 approved.

As part of our sustained investment in capacity and state of the art technology, we are now transitioning from the established Pd/Ag electrode system to a Base Metal Electrode system (BME).

AVX is using AECQ200 as the qualification vehicle for this transition. A detailed qualification package is available on request and contains results on a range of part numbers including:

- X7R dielectric components containing BME electrode and copper terminations with a Ni/Sn plated overcoat.
- X7R dielectric components, BME electrode with epoxy finish for conductive glue mounting.
- X7R dielectric components BME electrode and soft terminations with a Ni/Sn plated overcoat.
- NP0 dielectric components containing Pd/Ag electrode and silver termination with a Ni/Sn plated overcoat.

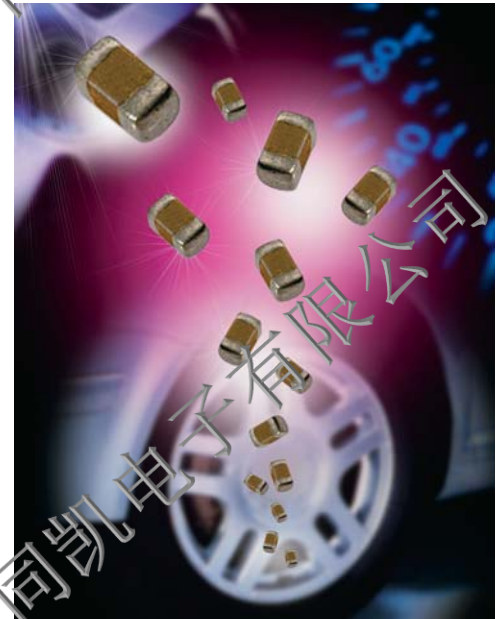

HOW TO ORDER

0805	5	A	104	K	4	T	2	A
Size	Voltage	Dielectric	Capacitance Code (In pF)	Capacitance Tolerance	Failure Rate	Terminations	Packaging	Special Code
0603 0805 1206 1210 1812	10V = Z 16V = Y 25V = 3 50V = 5 100V = 1 200V = 2 500V = 7	NP0 = A X7R = C X8R = F	2 Significant Digits + Number of Zeros e.g. 10µF = 106	J = ±5% K = ±10% M = ±20%	4 = Automotive	T = Plated Ni and Sn Z = FLEXITERM™ U = Conductive Epoxy	2 = 7" Reel 4 = 13" Reel	A = Std. Product

NOTE: Contact factory for non-specified capacitance values.

COMMERCIAL VS AUTOMOTIVE MLCC PROCESS COMPARISON

	Commercial	Automotive
Administrative	Standard Part Numbers. No restriction on who purchases these parts.	Specific Automotive Part Number. Used to control supply of product to Automotive customers.
Design	Minimum ceramic thickness of 0.020"	Minimum Ceramic thickness of 0.029" (0.74mm) on all X7R product.
Dicing	Side & End Margins = 0.003" min	Side & End Margins = 0.004" min Cover Layers = 0.005" min
Lot Qualification (Destructive Physical Analysis - DPA)	As per IEC 60384-21	Increased sample plan – stricter criteria.
Visual/Cosmetic Quality	Standard process and inspection	100% inspection
Application Robustness	Standard sampling for accelerated wave solder on X7R dielectrics	Increased sampling for accelerated wave solder on X7R and NP0 followed by lot by lot reliability testing.

All Tests have Accept/Reject Criteria 0/1

Automotive MLCC



NP0/X7R Dielectric

FLEXITERM™ FEATURES

a) Bend Test

The capacitor is soldered to the PC Board as shown:

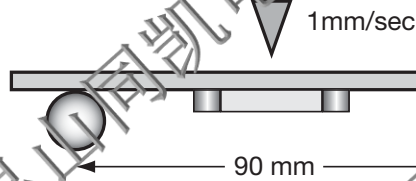

b) Temperature Cycle testing

“Soft Termination” has the ability to withstand at least 1000 cycles between -55°C and +125°C

Typical bend test results are shown below:

Style	Conventional Term	Soft Term
0603	>2mm	>5
0805	>2mm	>5
1206	>2mm	>5

ELECTRODE AND TERMINATION OPTIONS

NP0 DIELECTRIC

**NP0 Ag/Pd Electrode
Nickel Barrier Termination
PCB Application**

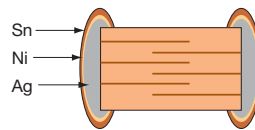

Figure 1 Termination Code T

X7R DIELECTRIC

**X7R Dielectric
PCB Application**

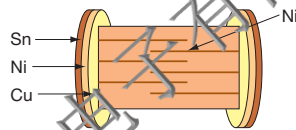

Figure 2 Termination Code T

**X7R Nickel Electrode
Soft Termination
PCB Application**

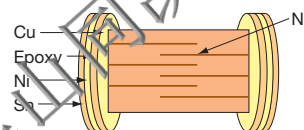

Figure 3 Termination Code Z

**Conductive Epoxy Termination
Hybrid Application**

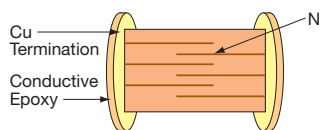

Figure 4 Termination Code U

Automotive MLCC NP0



Capacitance Range

		0402		0603			0805			1206					1210				1812	
		25V	50V	25V	50V	100V	25V	50V	100V	25V	50V	100V	200V	500V	25V	50V	100V	200V	50V	100V
100	10pF	C	C	G	G	G	J	J	J	J	J	J	J							
120	12	C	C	G	G	G	J	J	J	J	J	J	J							
150	15	C	C	G	G	G	J	J	J	J	J	J	J							
180	18	C	C	G	G	G	J	J	J	J	J	J	J							
220	22	C	C	G	G	G	J	J	J	J	J	J	J							
270	27	C	C	G	G	G	J	J	J	J	J	J	J							
330	33	C	C	G	G	G	J	J	J	J	J	J	J							
390	39	C	C	G	G	G	J	J	J	J	J	J	J							
470	47	C	C	G	G	G	J	J	J	J	J	J	J							
510	51	C	C	G	G	G	J	J	J	J	J	J	J							
560	56	C	C	G	G	G	J	J	J	J	J	J	J							
680	68	C	C	G	G	G	J	J	J	J	J	J	J							
820	82	C	C	G	G	G	J	J	J	J	J	J	J							
100	100	C	C	G	G	G	J	J	J	J	J	J	J							
120	120			G	G	G	J	J	J	J	J	J	J							
150	150			G	G	G	J	J	J	J	J	J	J							
180	180			G	G	G	J	J	J	J	J	J	J							
220	220			G	G	G	J	J	J	J	J	J	J							
270	270			G	G	G	J	J	J	J	J	J	J							
330	330			G	G	G	J	J	J	J	J	J	J							
390	390			G	G	G	J	J	J	J	J	J	J							
470	470			G	G	G	J	J	J	J	J	J	J							
560	560						J	J	J	J	J	J	J							
680	680						J	J	J	J	J	J	J							
820	820						J	J	J	J	J	J	J							
1000	1000						J	J	J	J	J	J	J							
1200	1200						J	J	J	J	J	J	J		J	J	J	J		
1500	1500								J	M	M	M	M		J	J	M	M	M	
1800	1800								J	M	M	M	M		J	J	M	M	M	
2200	2200								J	M	M	M	M		J	J	M	M	M	
2700	2700								J	M	M	M	M		J	J	M	M	M	
3300	3300								J	M	M	M	M		J	J	P	P		K K
3900	3900														J	J	P	P		K K
4700	4700														J	J	P	P		K K
103	10nF																			
		25V	50V	25V	50V	100V	25V	50V	100V	25V	50V	100V	200V	500V	25V	50V	100V	200V	50V	100V
		0402		0603			0805			1206					1210				1812	

Letter	A	C	E	G	J	K	M	N	P	Q	X	Y	Z
Max.	0.33	0.66	0.71	0.86	0.94	1.02	1.27	1.40	1.52	1.78	2.29	2.54	2.79
Thickness	(0.013)	(0.022)	(0.028)	(0.034)	(0.037)	(0.040)	(0.050)	(0.055)	(0.060)	(0.070)	(0.090)	(0.100)	(0.110)
	PAPER					EMBOSSED							

Automotive MLCC X7R



Capacitance Range

		0603					0805					1206					1210					1812		2220
		16V	25V	50V	100V	200V	16V	25V	50V	100V	200V	16V	25V	50V	100V	200V	500V	16V	25V	50V	100V	50V	100V	50V
102	Cap 1	G	G	G	G	G	J	J	J	J	J	J	J	J	J	J	K	K	K	K	K	K		
182	(nF) 1.8	G	G	G	G	G	J	J	J	J	J	J	J	J	J	J	K	K	K	K	K	K		
222	2.2	G	G	G	G	G	J	J	J	J	J	J	J	J	J	J	K	K	K	K	K	K		
332	3.3	G	G	G	G	G	J	J	J	J	J	J	J	J	J	J	K	K	K	K	K	K		
472	4.7	G	G	G	G	G	J	J	J	J	J	J	J	J	J	J	K	K	K	K	K	K		
103	10	G	G	G	G	G	J	J	J	J	J	J	J	J	J	J	K	K	K	K	K	K		
123	12	G	G	G	G	G	J	J	J	M		J	J	J	J	J	K	K	K	K	K	K		
153	15	G	G	G	G	G	J	J	J	M		J	J	J	J	J	K	K	K	K	K	K		
183	18	G	G	G	G	G	J	J	J	M		J	J	J	J	J	K	K	K	K	K	K		
223	22	G	G	G	G	G	J	J	J	M		J	J	J	J	J	K	K	K	K	K	K		
273	27	G	G	G	G	G	J	J	J	M		J	J	J	J	J	K	K	K	K	K	K		
333	33	G	G	G	G	G	J	J	J	M		J	J	J	J	J	K	K	K	K	K	K		
473	47	G	G	G	G	G	J	J	J	M		J	J	J	M		K	K	K	K	K	K		
563	56	G	G	G	G	G	J	J	J	M		J	J	J	M		K	K	K	M	K	K		
683	68	G	G	G	G	G	J	J	J	M		J	J	J	M		K	K	K	M	K	K		
823	82	G	G	G	G	G	J	J	J	M		J	J	J	M		K	K	K	M	K	K		
104	100	G	G	G			J	J	M			J	J	J	M		K	K	K	M	K	K		
124	120						J	J	M			J	J	M	M		K	K	K	P	K	K		
154	150						M	N	M			J	J	M	M		K	K	K	P	K	K		
224	220						M	N	M			J	M	M	Q		M	M	M	P	M	M		
334	330						N	N	M			J	M	P	Q		P	P	P	Q	X	X		
474	470						N	N	M			M	M	P	Q		P	P	P	Q	X	X		
684	680						N	N				M	Q	P	Q		P	P	Q	X	X	X		
105	Cap 1						N	N				M	Q	P	Q		P	Q	Q	X	X	X		
155	(µF) 1.5											Q	Q	Q			P	Q	Z	Z	X	X		
225	2.2											Q	Q	Q			X	Z	Z	Z	Z			
335	3.3																X	Z	Z	Z	Z			
475	4.7																X	Z	Z	Z	Z			
106	10																						Z	
		16V	25V	50V	100V	200V	16V	25V	50V	100V	200V	16V	25V	50V	100V	200V	500V	16V	25V	50V	100V	50V	100V	50V
		0603					0805					1206					1210					1812		2220
Letter		A	C	E	G	J	K	M	N	P	Q	X	Y	Z										
Max. Thickness		0.33 (0.013)	0.56 (0.022)	0.71 (0.028)	0.86 (0.034)	0.94 (0.037)	1.02 (0.040)	1.27 (0.050)	1.40 (0.055)	1.52 (0.060)	1.78 (0.070)	2.29 (0.090)	2.54 (0.100)	2.79 (0.110)										
PAPER										EMBOSSED														

Automotive MLCC X8R



Capacitance Range

SIZE		0603		0805		1206	
	WVDC	25V	50V	25V	50V	25V	50V
271	Cap	G	G				
331	(pF)	G	G	J	J		
471		G	G	J	J		
681		G	G	J	J		
102	1000	G	G	J	J	J	J
152	1500	G	G	J	J	J	J
182	1800	G	G	J	J	J	J
222	2200	G	G	J	J	J	J
272	2700	G	G	J	J	J	J
332	3300	G	G	J	J	J	J
392	3900	G	G	J	J	J	J
472	4700	G	G	J	J	J	J
562	5600	G	G	J	J	J	J
682	6800	G	G	J	J	J	J
822	8200	G	G	J	J	J	J
103	Cap	G	G	J	J	J	J
153	(uF)	G	G	J	J	J	J
183	0.012	G	G	J	J	J	J
223	0.015	G	G	J	J	J	J
273	0.018	G	G	J	J	J	J
333	0.022	G	G	J	J	J	J
393	0.027	G	G	J	J	J	J
473	0.033	G	G	J	J	J	J
563	0.039	G	G	J	J	J	J
683	0.047	G	G	J	J	J	J
823	0.056	G		N	N	N	M
104	0.068	G		N	N	N	M
124	0.082	G		N	N	N	M
154	0.1	G		N	N	N	M
184	0.12	G		N	N	N	M
224	0.15			N	N	N	M
274	0.18			N	N	N	M
334	0.22			N	N	N	M
394	0.27			N	N	N	M
474	0.33			N	N	N	M
564	0.39			N	N	N	M
684	0.47			N	N	N	M
824	0.68						M
105	0.82						
105	1						
SIZE	WVDC	25V	50V	25V	50V	25V	50V

Letter	A	C	E	G	J	K	M	N	P	Q	X	Y	Z
Max.	0.33	0.55	0.71	0.86	0.94	1.02	1.27	1.40	1.52	1.78	2.29	2.54	2.79
Thickness	(0.013)	(0.022)	(0.028)	(0.034)	(0.037)	(0.040)	(0.050)	(0.055)	(0.060)	(0.070)	(0.090)	(0.100)	(0.110)
	PAPER					EMBOSSED							

= AEC-Q200 Qualified
 = Under development (Contact factory for advanced samples)

APS Series



APS for COTS+ Applications



GENERAL DESCRIPTION

As part of our continuing support to high reliability customers, AVX has launched an Automotive Plus Series of parts (APS) qualified and manufactured in accordance with automotive AEC-Q200 standard. Each production batch is quality tested to an enhanced requirement and shipped with a certificate of conformance. On a quarterly basis a reliability package is issued to all APS customers.

A detailed Qualification package is available on request and contains results on a range of part numbers including:

- X7R dielectric components containing BME electrode and copper terminations with a Ni/Sn plated overcoat.
- X7R dielectric components BME electrode and soft terminations with a Ni/Sn plated overcoat (FLEXITERM™).
- X7R for Hybrid applications.
- NP0 dielectric components containing Pd/Ag electrode and silver termination with a Ni/Sn plated overcoat.

We are also able to support customers who require an AEC-Q200 grade component finished with Tin/Lead.

HOW TO ORDER

AP03	5	A	104	K	Q	T	2	A
Size	Voltage	Dielectric	Capacitance Code (In pF)	Capacitance Tolerance	Failure Rate	Terminations	Packaging	Special Code
AP03=0603	16V = 1	NP0 = A	2 Significant Digits + Number of Zeros e.g. 10µF = 106	J = ±5% K = ±10% M = ±20%	Q = APS	T = Plated Ni and Sn** Z = FLEXITERM™** U = Conductive Epoxy** B = 5% min lead X = FLEXITERM™ with 5% min lead	2 = 7" Reel 4 = 13" Reel	A = Std. Product
AP05=0805	25V = 3	X7R = C						
AP06=1206	50V = 3							
AP10=1210	100V = 1							
AP12=1812	200V = 2 300V = 7							

**RoHS compliant

NOTE: Contact factory for availability of Termination and Tolerance Options for Specific Part Numbers.

NP0 Automotive Plus Series / APS



Capacitance Range

		0603			0805			1206					1210				1812	
		25V	50V	100V	25V	50V	100V	25V	50V	100V	200V	500V	25V	50V	100V	200V	50V	100V
100	10pF	G	G	G	J	J	J	J	J	J	J	J						
120	12	G	G	G	J	J	J	J	J	J	J	J						
150	15	G	G	G	J	J	J	J	J	J	J	J						
180	18	G	G	G	J	J	J	J	J	J	J	J						
220	22	G	G	G	J	J	J	J	J	J	J	J						
270	27	G	G	G	J	J	J	J	J	J	J	J						
330	33	G	G	G	J	J	J	J	J	J	J	J						
390	39	G	G	G	J	J	J	J	J	J	J	J						
470	47	G	G	G	J	J	J	J	J	J	J	J						
510	51	G	G	G	J	J	J	J	J	J	J	J						
560	56	G	G	G	J	J	J	J	J	J	J	J						
680	68	G	G	G	J	J	J	J	J	J	J	J						
820	82	G	G	G	J	J	J	J	J	J	J	J						
100	100	G	G	G	J	J	J	J	J	J	J	J						
120	120	G	G	G	J	J	J	J	J	J	J	J						
150	150	G	G	G	J	J	J	J	J	J	J	J						
180	180	G	G	G	J	J	J	J	J	J	J	J						
220	220	G	G	G	J	J	J	J	J	J	J	J						
270	270	G	G	G	J	J	J	J	J	J	J	J						
330	330	G	G	G	J	J	J	J	J	J	J	J						
390	390	G	G	G	J	J	J	J	J	J	J	J						
470	470	G	G	G	J	J	J	J	J	J	J	J						
560	560				J	J	J	J	J	J	J	J						
680	680				J	J	J	J	J	J	J	J						
820	820				J	J	J	J	J	J	J	J						
1000	1000				J	J	J	J	J	J	J	J	J	J	J			
1200	1200												J	J	M	M		
1500	1500												J	J	M	M		
1800	1800												J	J	M	M		
2200	2200												J	J	M	M		
2700	2700												J	J	M	M		
3300	3300												J	J	M	M		
3900	3900												J	J	P		K	K
4700	4700												J	J	P		K	K
100nF	10nF												J	J	P		K	K
		0603			0805			1206					1210				1812	

Letter	A	C	E	G	J	K	M	N	P	Q	X	Y	Z
Max. Thickness	0.33 (0.013)	0.50 (0.020)	0.71 (0.028)	0.86 (0.034)	0.94 (0.037)	1.02 (0.040)	1.27 (0.050)	1.40 (0.055)	1.52 (0.060)	1.78 (0.070)	2.29 (0.090)	2.54 (0.100)	2.79 (0.110)
	PAPER					EMBOSSED							

AEC-Q200 qualified
TS 16949, ISO 9001 certified



X7R Automotive Plus Series / APS



Capacitance Range

		0603					0805					1206					1210					1812		2220
		16V	25V	50V	100V	200V	16V	25V	50V	100V	200V	16V	25V	50V	100V	200V	500V	16V	25V	50V	100V	50V	100V	50V
102	Cap 1	G	G	G	G	G	J	J	J	J	J	J	J	J	J	J	K	K	K	K	K	K		
182	(nF) 1.8	G	G	G	G	G	J	J	J	J	J	J	J	J	J	J	K	K	K	K	K	K		
222	2.2	G	G	G	G	G	J	J	J	J	J	J	J	J	J	J	K	K	K	K	K	K		
332	3.3	G	G	G	G	G	J	J	J	J	J	J	J	J	J	J	K	K	K	K	K	K		
472	4.7	G	G	G	G	G	J	J	J	J	J	J	J	J	J	J	K	K	K	K	K	K		
103	10	G	G	G	G	G	J	J	J	J	J	J	J	J	J	J	K	K	K	K	K	K		
123	12	G	G	G	G	G	J	J	J	M		J	J	J	J		K	K	K	K	K	K		
153	15	G	G	G	G	G	J	J	J	M		J	J	J	J		K	K	K	K	K	K		
183	18	G	G	G	G	G	J	J	J	M		J	J	J	J		K	K	K	K	K	K		
223	22	G	G	G	G	G	J	J	J	M		J	J	J	J		K	K	K	K	K	K		
273	27	G	G	G	G	G	J	J	J	M		J	J	J	J		K	K	K	K	K	K		
333	33	G	G	G	G	G	J	J	J	M		J	J	J	J		K	K	K	K	K	K		
473	47	G	G	G	G	G	J	J	J	M		J	J	J	M		K	K	K	K	K	K		
563	56	G	G	G	G	G	J	J	J	M		J	J	J	M		K	K	K	M	K	K		
683	68	G	G	G	G	G	J	J	J	M		J	J	J	M		K	K	K	M	K	K		
823	82	G	G	G	G	G	J	J	J	M		J	J	J	M		K	K	K	M	K	K		
104	100	G	G	G			J	J	M			J	J	J	M		K	K	K	M	K	K		
124	120						J	J	M			J	J	M	M		K	K	K	P	K	K		
154	150						M	N	M			J	J	M	M		K	K	K	P	K	K		
224	220						M	N	M			J	M	M	Q		M	M	M	P	M	M		
334	330						N	N	M			J	M	P	Q		P	P	P	Q	X	X		
474	470						N	N	M			M	M	P	Q		P	P	P	Q	X	X		
684	680						N	N				M	Q	P	Q		P	P	Q	X	X	X		
105	Cap 1						N	N				M	S	Q			P	Q	Q	X	X	X		
155	(µF) 1.5											Q	Q	Q			P	Q	Z	X	X	X		
225	2.2											Q	Q	Q			X	Z	Z	Z	Z	Z		
335	3.3																X	Z	Z	Z	Z	Z		
475	4.7																X	Z	Z	Z	Z	Z		
106	10																						Z	
		16V	25V	50V	100V	200V	16V	25V	50V	100V	200V	16V	25V	50V	100V	200V	500V	16V	25V	50V	100V	50V	100V	50V
		0603					0805					1206					1210					1812		2220

Letter	A	C	E	G	J	K	M	N	P	Q	X	Y	Z		
Max.	0.33	0.56	0.71	0.86	0.94	1.02	1.27	1.40	1.52	1.78	2.29	2.54	2.79		
Thickness	(0.013)	(0.022)	(0.028)	(0.034)	(0.037)	(0.040)	(0.050)	(0.055)	(0.060)	(0.070)	(0.090)	(0.100)	(0.110)		
	PAPER								EMBOSSED						

AEC-Q200 qualified
 TS 16949, ISO 9001 certified



MLCC with FLEXITERM™



General Specifications

GENERAL DESCRIPTION

With increased requirements from the automotive industry for additional component robustness, AVX recognized the need to produce a MLCC with enhanced mechanical strength. It was noted that many components may be subject to severe flexing and vibration when used in various under the hood automotive and other harsh environment applications.

To satisfy the requirement for enhanced mechanical strength, AVX had to find a way of ensuring electrical integrity is maintained whilst external forces are being applied to the component. It was found that the structure of the termination needed to be flexible and after much research and development, AVX launched FLEXITERM™. FLEXITERM™ is designed to enhance the mechanical flexure and temperature cycling performance of a standard ceramic capacitor with an X7R dielectric. **The industry standard for flexure is 2mm minimum. Using FLEXITERM™, AVX provides up to 5mm of flexure without internal cracks. Beyond 5mm, the capacitor will generally fail “open”.**

As well as for automotive applications FLEXITERM™ will provide Design Engineers with a satisfactory solution when designing PCB's which may be subject to high levels of board flexure.

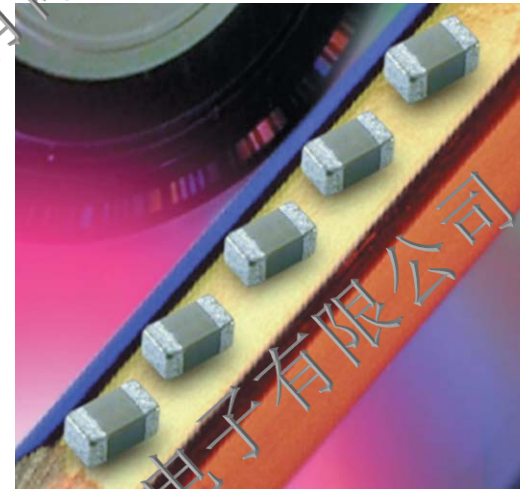

PRODUCT ADVANTAGES

- High mechanical performance able to withstand, 5mm bend test guaranteed.
- Increased temperature cycling performance, 3000 cycles and beyond.
- Flexible termination system.
- Reduction in circuit board flex failures.
- Base metal electrode system.
- Automotive or commercial grade products available.

APPLICATIONS

High Flexure Stress Circuit Boards

- e.g. Depanelization: Components near edges of board.

Variable Temperature Applications

- Soft termination offers improved reliability performance in applications where there is temperature variation.
- e.g. All kind of engine sensors: Direct connection to battery rail.

Automotive Applications

- Improved reliability.
- Excellent mechanical performance and thermo mechanical performance.

HOW TO ORDER

0805

Style
0603
0805
1206
1210
1812

5

Voltage
6 = 6.3V
Z = 10V
Y = 16V
3 = 25V
5 = 50V
1 = 100V
2 = 200V

C

Dielectric
C = X7R
F = X8R

104

Capacitance Code (in pF)
2 Sig. Digits +
Number of Zeros
e.g., 104 = 100nF

K

Capacitance Tolerance
J = ±5%
K = ±10%
M = ±20%

A

Failure Rate
A = Commercial
4 = Automotive

Z

Terminations
Z = FLEXITERM™

2

Packaging
2 = 7" reel
4 = 13" reel

A

Special Code
A = Std. Product

NOTE: Contact factory for availability of Tolerance Options for Specific Part Numbers.

Specifications and Test Methods

PERFORMANCE TESTING

AEC-Q200 Qualification:

- Created by the Automotive Electronics Council
- Specification defining stress test qualification for passive components

Testing:

Key tests used to compare soft termination to AEC-Q200 qualification:

- Bend Test
- Temperature Cycle Test



BOARD BEND TEST PROCEDURE

According to AEC-Q200

Test Procedure as per AEC-Q200:

Sample size: 20 components
Span: 90mm Minimum deflection spec: 2 mm

- Components soldered onto FR4 PCB (Figure 1)
- Board connected electrically to the test equipment (Figure 2)

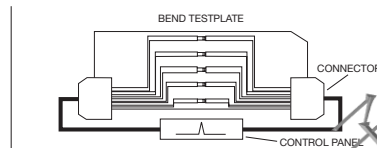

Fig 1 - PCB layout with electrical connections

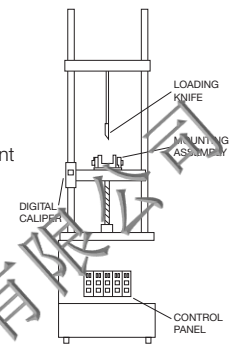
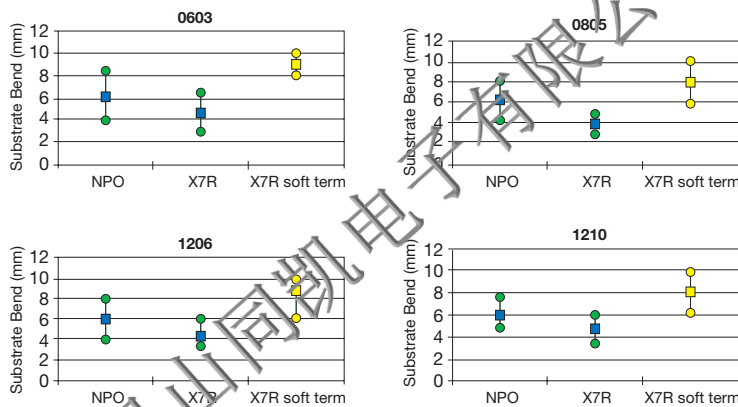

Fig 2 - Board Bend test equipment

BOARD BEND TEST RESULTS

AEC-Q200 Vrs AVX FLEXITERM™ Bend Test



AVX ENHANCED SOFT TERMINATION BEND TEST PROCEDURE

Bend Test

The capacitor is soldered to the printed circuit board as shown and is bent up to 10mm at 1mm per second:

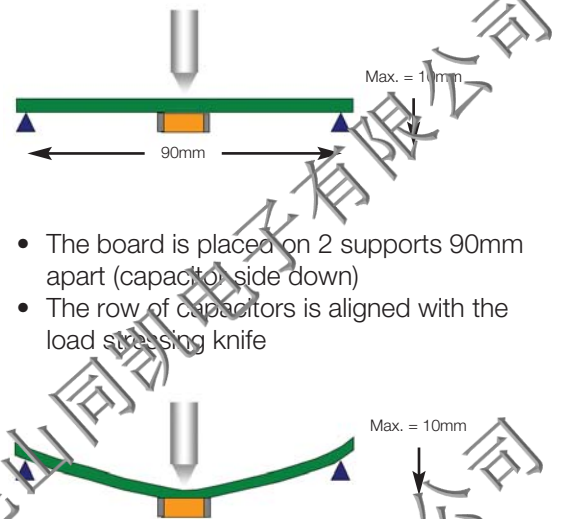

- The board is placed on 2 supports 90mm apart (capacitor side down)
- The row of capacitors is aligned with the load stressing knife

- The load is applied and the deflection where the part starts to crack is recorded (Note: Equipment detects the start of the crack using a highly sensitive current detection circuit)
- The maximum deflection capability is 10mm

TABLE SUMMARY

Typical bend test results are shown below:

Style	Conventional Termination	FLEXITERM™
0603	>2mm	>5mm
0805	>2mm	>5mm
1206	>2mm	>5mm

TEMPERATURE CYCLE TEST PROCEDURE

Test Procedure as per AEC-Q200:

The test is conducted to determine the resistance of the component when it is exposed to extremes of alternating high and low temperatures.

- Sample lot size quantity 70 pieces
- TC chamber cycle from -55°C to +125°C for 1000 cycles
- Interim electrical measurements at 250, 500, 1000 cycles
- Measure parameter capacitance dissipation factor, insulation resistance

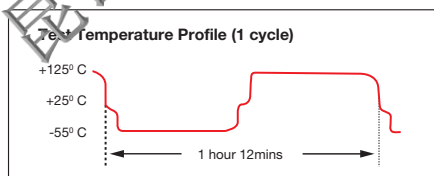

MLCC with FLEXITERM™



Specifications and Test Methods

BEYOND 1000 CYCLES, TEMPERATURE CYCLE TEST RESULTS

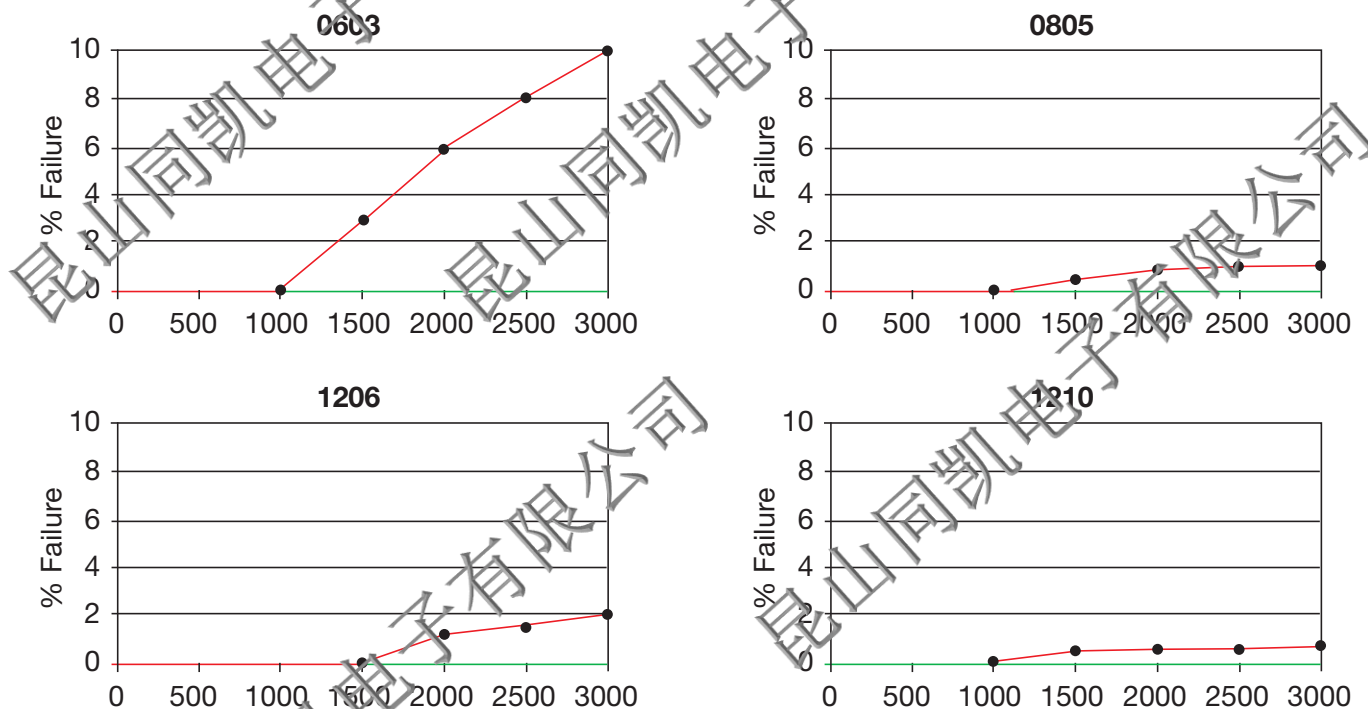

Soft Term - No Defects up to 3000 cycles

AEC-Q200 specification states 1000 cycles compared to AVX 3000 temperature cycles.

FLEXITERM™ TEST SUMMARY

- Qualified to AEC-Q200 test/specification with the exception of using AVX 3000 temperature cycles (up to +150°C bend test guaranteed greater than 5mm).
- FLEXITERM™ provides improved performance compared to standard termination systems.
- Board bend test improvement by a factor of 2 to 4 times.
- Temperature Cycling:
 - 0% Failure up to 3000 cycles
 - No ESR change up to 3000 cycles

WITHOUT SOFT TERMINATION

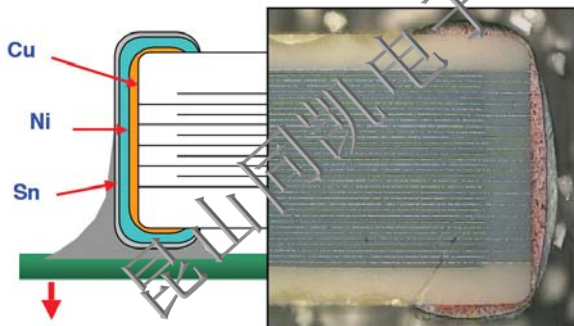

Major fear is of latent board flex failures.

WITH SOFT TERMINATION

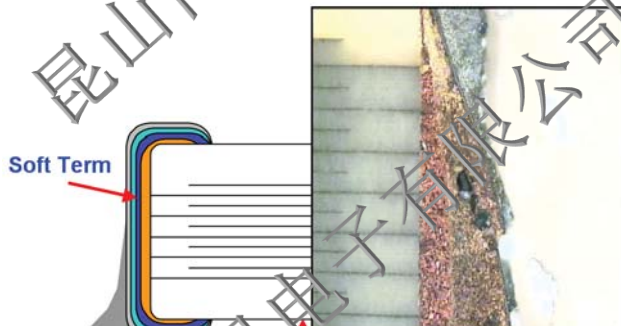

Far superior mechanical performance. Generally open failure mode beyond 5mm flexure.

MLCC with FLEXITERM™



X8R Dielectric Capacitance Range

SIZE		0603		0805		1206	
	WVDC	25V	50V	25V	50V	25V	50V
271	Cap	G	G				
331	(pF)	G	G	J	J		
471		G	G	J	J		
681		G	G	J	J		
102	1000	G	G	J	J	J	J
152	1500	G	G	J	J	J	J
182	1800	G	G	J	J	J	J
222	2200	G	G	J	J	J	J
272	2700	G	G	J	J	J	J
332	3300	G	G	J	J	J	J
392	3900	G	G	J	J	J	J
472	4700	G	G	J	J	J	J
562	5600	G	G	J	J	J	J
682	6800	G	G	J	J	J	J
822	8200	G	G	J	J	J	J
103	Cap	G	G	J	J	J	J
153	(µF)	G	G	J	J	J	J
183	0.012	G	G	J	J	J	J
223	0.015	G	G	J	J	J	J
273	0.018	G	G	J	J	J	J
333	0.022	G	G	J	J	J	J
393	0.027	G	G	J	J	J	J
473	0.033	G	G	J	J	J	J
563	0.039	G	G	J	J	J	J
683	0.047	G	G	J	J	J	J
823	0.056	G		N	N	N	M
104	0.068	G		N	N	N	M
124	0.082	G		N	N	N	M
154	0.1	G		N	N	N	M
184	0.12	G		N	N	N	M
224	0.15			N	N	N	M
274	0.18			N	N	N	M
334	0.22			N	N	N	M
394	0.27			N	N	N	M
474	0.33			N	N	N	M
564	0.39			N	N	N	M
684	0.47			N	N	N	M
824	0.68						M
105	0.82						
105	1						
SIZE	WVDC	25V	50V	25V	50V	25V	50V

Letter	A	C	E	G	J	K	M	N	P	Q	X	Y	Z
Max.	0.33	0.5	0.71	0.86	0.94	1.02	1.27	1.40	1.52	1.78	2.29	2.54	2.79
Thickness	(0.013)	(0.022)	(0.028)	(0.034)	(0.037)	(0.040)	(0.050)	(0.055)	(0.060)	(0.070)	(0.090)	(0.100)	(0.110)
	PAPER					EMBOSSED							

= AEC-Q200 Qualified
 = Under development (Contact factory for advanced samples)

Capacitor Array



Capacitor Array (IPC)

BENEFITS OF USING CAPACITOR ARRAYS

AVX capacitor arrays offer designers the opportunity to lower placement costs, increase assembly line output through lower component count per board and to reduce real estate requirements.

Reduced Costs

Placement costs are greatly reduced by effectively placing one device instead of four or two. This results in increased throughput and translates into savings on machine time. Inventory levels are lowered and further savings are made on solder materials, etc.

Space Saving

Space savings can be quite dramatic when compared to the use of discrete chip capacitors. As an example, the 0508 4-element array offers a space reduction of >40% vs. 4 x 0402 discrete capacitors and of >70% vs. 4 x 0603 discrete capacitors. (This calculation is dependent on the spacing of the discrete components.)

Increased Throughput

Assuming that there are 220 passive components placed in a mobile phone:

A reduction in the passive count to 200 (by replacing discrete components with arrays) results in an increase in throughput of approximately 9%.

A reduction of 40 placements increases throughput by 18%.

For high volume users of cap arrays using the very latest placement equipment capable of placing 10 components per second, the increase in throughput can be very significant and can have the overall effect of reducing the number of placement machines required to mount components:

If 120 million 2-element arrays or 40 million 4-element arrays were placed in a year, the requirement for placement equipment would be reduced by one machine.

During a 20Hr operational day a machine places 720K components. Over a working year of 167 days the machine can place approximately 120 million. If 2-element arrays are mounted instead of discrete components, then the number of placements is reduced by a factor of two and in the scenario where 120 million 2-element arrays are placed there is a saving of one pick and place machine.

Smaller volume users can also benefit from replacing discrete components with arrays. The total number of placements is reduced thus creating spare capacity on placement machines. This in turn generates the opportunity to increase overall production output without further investment in new equipment.

W2A (0508) Capacitor Arrays

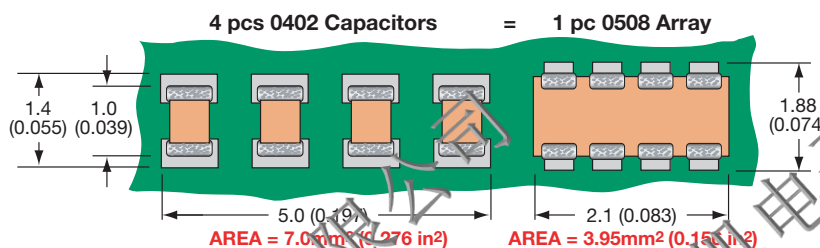

The 0508 4-element capacitor array gives a PCB space saving of over 40% vs four 0402 discretés and over 70% vs four 0603 discrete capacitors.

W3A (0612) Capacitor Arrays

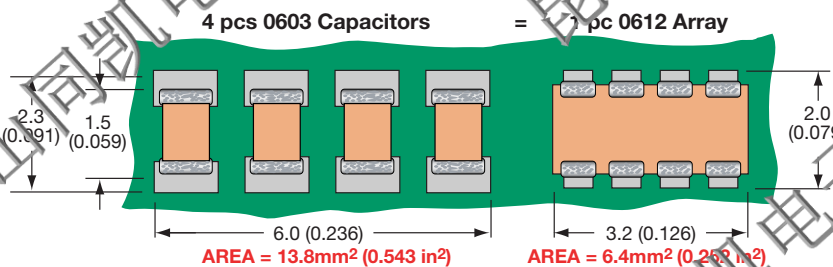

The 0612 4-element capacitor array gives a PCB space saving of over 50% vs four 0603 discretés and over 70% vs four 0805 discrete capacitors.



Capacitor Array

Capacitor Array (IPC)

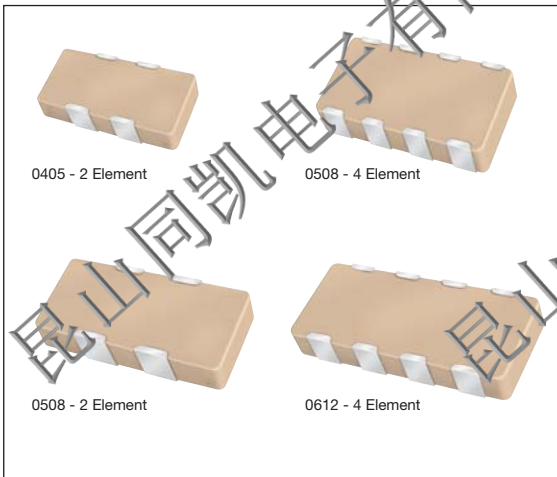

GENERAL DESCRIPTION

AVX is the market leader in the development and manufacture of capacitor arrays. The smallest array option available from AVX, the 0405 2-element device, has been an enormous success in the Telecommunications market. The array family of products also includes the 0612 4-element device as well as 0508 2-element and 4-element series, all of which have received widespread acceptance in the marketplace.

AVX capacitor arrays are available in X5R, X7R and NP0 (COG) ceramic dielectrics to cover a broad range of capacitance values. Voltage ratings from 6.3 Volts up to 100 Volts are offered. AVX also now offers a range of automotive capacitor arrays qualified to AEC-Q200 (see separate table).

Key markets for capacitor arrays are Mobile and Cordless Phones, Digital Set Top Boxes, Computer Motherboards and Peripherals as well as Automotive applications, RF Modems, Networking Products, etc.

AVX Capacitor Array - W2A41A***K
S21 Magnitude

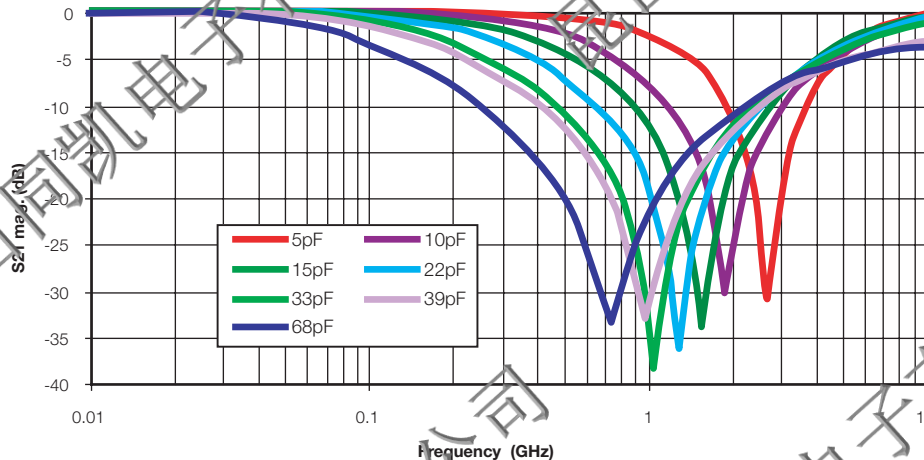

HOW TO ORDER

W	2	A	4	3	C	103	M	A	T	2A
Style	Case Size	Array	Number of Caps	Voltage	Dielectric	Capacitance Code	Capacitance Tolerance	Failure Rate	Termination Code	Packaging & Quantity Code
	1 = 0405 2 = 0508 3 = 0612			Z = 10V 3 = 16V 3 = 25V 5 = 50V 1 = 100V	A = NP0 C = X7R D = X5R	2 Sig Digits + Number of Zeros	J = ±5% K = ±10% M = ±20%	A = Commercial 4 = Automotive	T = Plated Ni and Sn** Z = FLEXITERM™** B = 5% min lead X = FLEXITERM™ with 5% min lead	2A = 7" Reel (4000) 4A = 13" Reel (10000) 2F = 7" Reel (1000)
									**RoHS compliant	

NOTE: Contact factory for availability of Termination and Tolerance Options for Specific Part Numbers.



Capacitor Array

Capacitance Range – NP0/C0G



SIZE		0405				0508				0508				0612			
# Elements		2				2				4				4			
Soldering		Reflow Only				Reflow/Wave				Reflow/Wave				Reflow/Wave			
Packaging		All Paper				All Paper				Paper/Embossed				Paper/Embossed			
Length	MM	1.00 ± 0.15				1.30 ± 0.15				1.30 ± 0.15				1.60 ± 0.150			
	(in.)	(0.039 ± 0.006)				(0.051 ± 0.006)				(0.051 ± 0.006)				(0.063 ± 0.006)			
Width	MM	1.37 ± 0.15				2.10 ± 0.15				2.25 ± 0.15				3.20 ± 0.20			
	(in.)	(0.054 ± 0.006)				(0.083 ± 0.006)				(0.089 ± 0.006)				(0.126 ± 0.008)			
Max. Thickness	MM	0.66				0.94				0.94				1.35			
	(in.)	(0.026)				(0.037)				(0.037)				(0.053)			
WVDC		16	25	50	16	25	50	100	16	25	50	100	16	25	50	100	
1R0	1.0																
1R2	1.2																
1R5	1.5																
1R8	1.8																
2R2	2.2																
2R7	2.7																
3R3	3.3																
3R9	3.9																
4R7	4.7																
5R6	5.6																
6R8	6.8																
8R2	8.2																
100	10																
120	12																
150	15																
180	18																
220	22																
270	27																
330	33																
390	39																
470	47																
560	56																
680	68																
820	82																
101	100																
121	120																
151	150																
181	180																
221	220																
271	270																
331	330																
391	390																
471	470																
561	560																
681	680																
821	820																
102	1000																
122	1200																
152	1500																
182	1800																
222	2200																
272	2700																
332	3300																
392	3900																
472	4700																
562	5600																
682	6800																
822	8200																

Capacitor Array

Capacitance Range - X7R/X5R



SIZE		0306				0405				0508					0508					0612								
# Elements		4				2				2					4					4								
Soldering		Reflow Only				Reflow Only				Reflow/Wave					Reflow/Wave					Reflow/Wave								
Packaging		All Paper				All Paper				All Paper					Paper/Embossed					Paper/Embossed								
Length	MM	1.60 ± 0.15				1.00 ± 0.15				1.30 ± 0.15					1.30 ± 0.15					1.60 ± 0.150								
	(in.)	(0.063 ± 0.006)				(0.039 ± 0.006)				(0.051 ± 0.006)					(0.051 ± 0.006)					(0.063 ± 0.006)								
Width	MM	0.81 ± 0.15				1.37 ± 0.15				1.30 ± 0.15					2.10 ± 0.15					3.20 ± 0.20								
	(in.)	(0.032 ± 0.006)				(0.054 ± 0.006)				(0.083 ± 0.006)					(0.083 ± 0.006)					(0.126 ± 0.008)								
Max. Thickness	MM	0.50				0.66				0.94					0.94					1.35								
	(in.)	(0.020)				(0.026)				(0.037)					(0.037)					(0.053)								
WVDC		6	10	16	25	6	10	16	25	30	6	10	16	25	50	100	6	10	16	25	50	100	6	10	16	25	50	100
101	Cap	100																										
121	(µF)	120																										
151		150																										
181		180																										
221		220																										
271		270																										
331		330																										
391		390																										
471		470																										
561		560																										
681		680																										
821		820																										
102		1000																										
122		1200																										
152		1500																										
182		1800																										
222		2200																										
272		2700																										
332		3300																										
392		3900																										
472		4700																										
562		5600																										
682		6800																										
822		8200																										
103	Cap	0.010																										
123	(µF)	0.012																										
153		0.015																										
183		0.018																										
223		0.022																										
273		0.027																										
333		0.033																										
393		0.039																										
473		0.047																										
563		0.056																										
683		0.068																										
823		0.082																										
104		0.10																										
124		0.12																										
154		0.15																										
184		0.18																										
224		0.22																										
274		0.27																										
334		0.33																										
474		0.47																										
564		0.56																										
684		0.68																										
824		0.82																										
105		1.0																										
125		1.2																										
155		1.5																										
185		1.8																										
225		2.2																										
335		3.3																										
475		4.7																										
106		10																										
226		22																										
476		47																										
107		100																										

- = Currently available X7R
- = Currently available X5R
- = Under development X7R, contact factory for advance samples
- = Under development X5R, contact factory for advance samples



Automotive Capacitor Array (IPC)

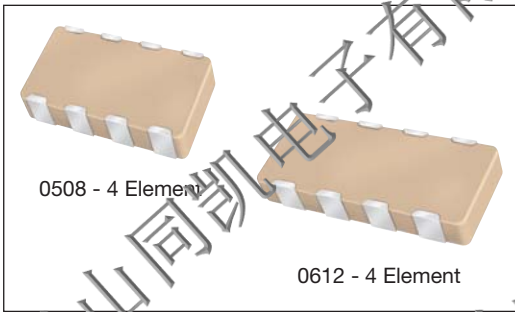

As the market leader in the development and manufacture of capacitor arrays AVX is pleased to offer a range of AEC-Q200 qualified arrays to compliment our product offering to the Automotive industry. Both the AVX 0612 and 0508 4-element capacitor array styles are qualified to the AEC-Q200 automotive specifications.

AEC-Q200 is the Automotive Industry qualification standard and a detailed qualification package is available on request.

All AVX automotive capacitor array production facilities are certified to ISO/TS 16949:2002.

HOW TO ORDER

W	3	A	4	Y	C	104	K	4	T	2A
Style	Case Size	Array	Number of Caps	Voltage	Dielectric	Capacitance Code (10 pF)	Capacitance Tolerance	Failure Rate	Terminations	Packaging & Quantity Code
	2 = 0508 3 = 0612			6 = 6.3V Z = 10V Y = 16V 3 = 25V 5 = 50V 1 = 100V	A = NP0 C = X7R	Significant Digits + Number of Zeros e.g. 10µF=106	*J = ±5% *K = ±10% M = ±20%	4 = Automotive	T = Plated Ni and Sn** Z = FLEXITERM™** B = 5% min lead X = FLEXITERM™ with 5% min lead	2A = 7" Reel (4000) 4A = 13" Reel (10000) 2F = 7" Reel (1000)

*Contact factory for availability by part number for K = ±10% and J = ±5% tolerance.

**RoHS compliant

NP0/COG

SIZE	0508					0612				
	No. of Elements					No. of Elements				
WVDC	2	2	2	2	2	4	4	4	4	4
1R0 Cap 1.0 (pF)										
1R2 1.2										
1R5 1.5										
1R8 1.8										
2R2 2.2										
2R7 2.7										
3R3 3.3										
3R9 3.9										
4R7 4.7										
5R6 5.6										
6R8 6.8										
8R2 8.2										
10 10										
12 12										
15 15										
18 18										
22 22										
27 27										
33 33										
39 39										
47 47										
56 56										
68 68										
82 82										
101 100										
121 120										
151 150										
181 180										
221 220										
271 270										
331 330										
391 390										
471 470										
561 560										
681 680										
821 820										
102 1000										
122 1200										
152 1500										
182 1800										
222 2200										
272 2700										
332 3300										
392 3900										
472 4700										
562 5600										
682 6800										
822 8200										

■ = NP0/COG

X7R

SIZE	0508				0508				0612			
	No. of Elements				No. of Elements				No. of Elements			
WVDC	2	2	2	2	4	4	4	4	4	4	4	4
101 Cap 100 (pF)												
121 120												
151 150												
181 180												
221 220												
271 270												
331 330												
391 390												
471 470												
561 560												
681 680												
821 820												
102 1000												
122 1200												
152 1500												
182 1800												
222 2200												
272 2700												
332 3300												
392 3900												
472 4700												
562 5600												
682 6800												
822 8200												
103 Cap 0.010 (µF)												
123 0.012												
153 0.015												
183 0.018												
223 0.022												
273 0.027												
333 0.033												
393 0.039												
473 0.047												
563 0.056												
683 0.068												
823 0.082												
104 0.10												
124 0.12												
154 0.15												

■ = X7R



Capacitor Array

Multi-Value Capacitor Array (IPC)



GENERAL DESCRIPTION

A recent addition to the array product range is the Multi-Value Capacitor Array. These devices combine two different capacitance values in standard 'Cap Array' packages and are available with a maximum ratio between the two capacitance values of 100:1. The multi-value array is currently available in the 0405 and 0508 2-element styles and also in the 0612 4-element style.

Whereas to date AVX capacitor arrays have been suited to applications where multiple capacitors of the same value are used, the multi-value array introduces a new flexibility to the range. The multi-value array can replace discrete capacitors of different values and can be used for broadband decoupling applications. The 0508 x 2 element multi-value array would be particularly recommended in this application. Another application is filtering the 900/1800 or 1900MHz noise in mobile phones. The 0405 2-element, low capacitance value NP0, (C0G) device would be suited to this application, in view of the space saving requirements of mobile phone manufacturers.

ADVANTAGES OF THE MULTI-VALUE CAPACITOR ARRAYS

Enhanced Performance Due to Reduced Parasitic Inductance

When connected in parallel, not only do discrete capacitors of different values give the desired self-resonance, but an additional unwanted parallel resonance also results. This parallel resonance is induced between each capacitor's self-resonant frequencies and produces a peak in impedance response. For decoupling and bypassing applications this peak will result in a frequency band of reduced decoupling and in filtering applications reduced attenuation.

The multi-value capacitor array combining capacitors in one unit, virtually eliminates the problematic parallel resonance, by minimizing parasitic inductance between the capacitors, thus enhancing the broadband decoupling/filtering performance of the part.

Reduced ESR

An advantage of connecting two capacitors in parallel is a significant reduction in ESR. However, as stated above, using discrete components brings with it the unwanted side effect of parallel resonance. The multi-value cap array is an excellent alternative as not only does it perform the same function as parallel capacitors but also it reduces the uncertainty of the frequency response.

HOW TO ORDER (Multi-Value Capacitor Array - IPC)

W	2	A	2	Y	C	102M	104M	A	T	2A
Style	Case Size	Array	Number of Caps	Voltage	Dielectric	Capacitance Code (In pF)	Capacitance Tolerance	Failure Rate	Terminations	Packaging & Quantity Code
	1 = 0405 2 = 0508 3 = 0612			Z = 10V Y = 16V 3 = 25V 5 = 50V 1 = 100V	A = NP0 C = X7R D = X5R	2 Sig. Digits + No. of Zeros	K = ±10% M = ±20%		T = Plated Ni and Sn** Z = FLEXITERM™** B = 5% min lead X = FLEXITERM™ with 5% min lead	2A = 7" Reel (4000) 4A = 13" Reel (10000) 2F = 7" Reel (1000)

NOTE: Contact factory for availability of Termination and Tolerance Options for Specific Part Numbers.

**RoHS compliant

	Cap (Min/Max)	
	NP0	X5R/X7R
0612 4-element	100/471	221/104
0508 2-element	100/471	221/104
0405 2-element	100/101	101/103

- Max. ratio between the two cap values is 1:100.
- The voltage of the higher capacitance value dictates the voltage of the multi-value part.
- Only combinations of values within a specific dielectric range are possible.

IMPEDANCE VS FREQUENCY

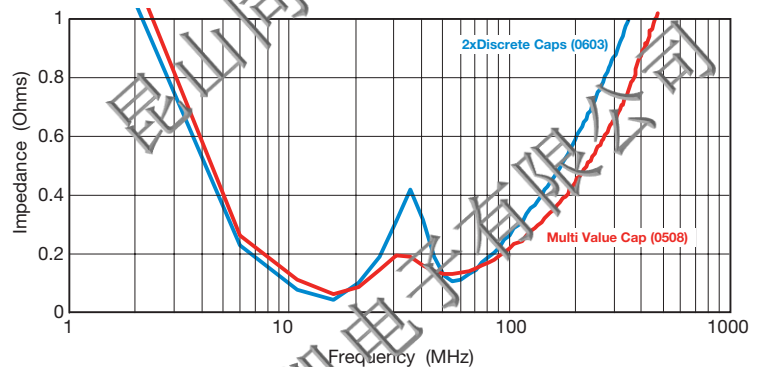

PART & PAD LAYOUT DIMENSIONS

millimeters (inches)

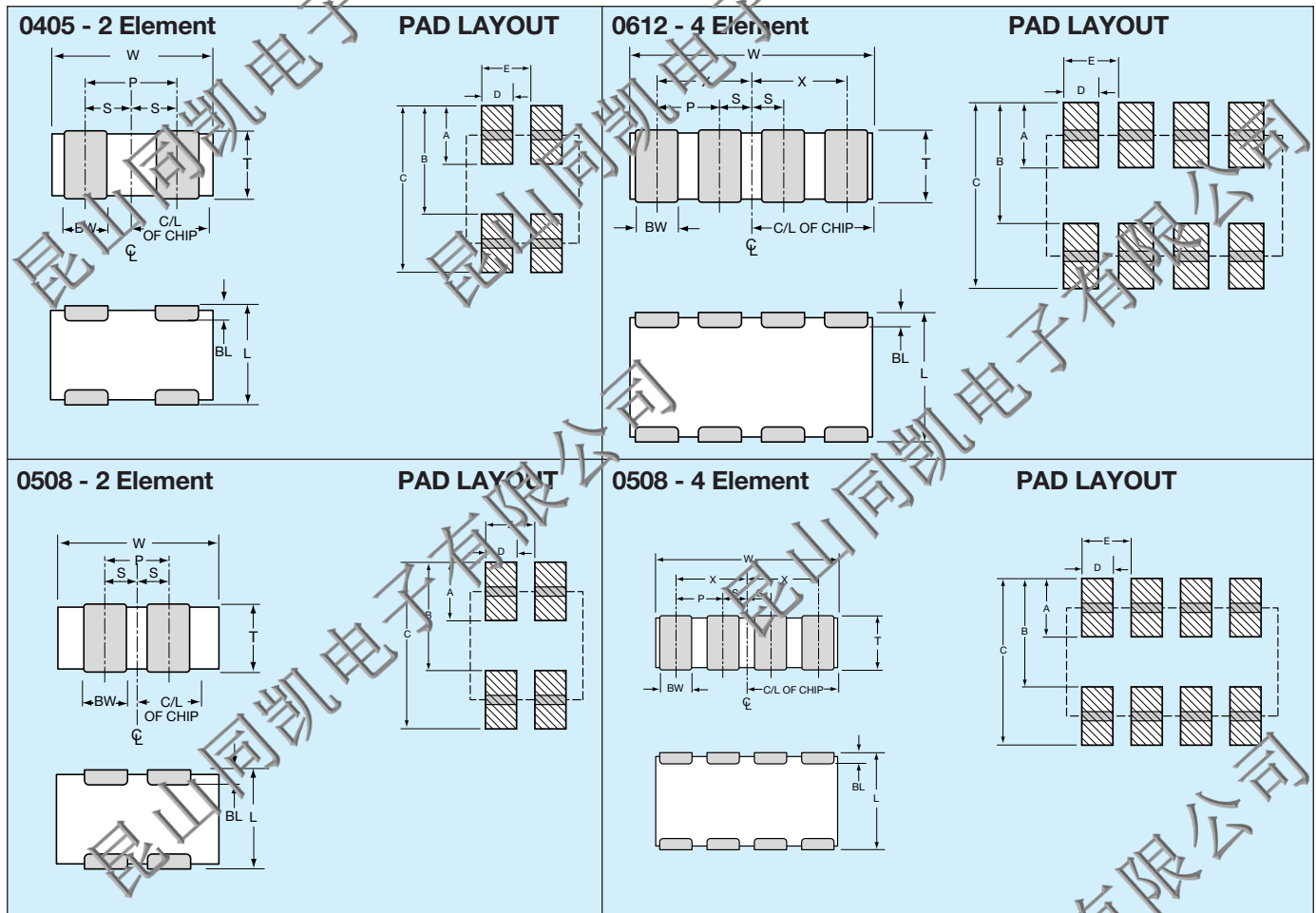

PART DIMENSIONS

0405 - 2 Element

L	W	T	BW	BL	P	S
1.00 ± 0.15 (0.039 ± 0.006)	1.37 ± 0.15 (0.054 ± 0.006)	0.66 MAX (0.026 MAX)	0.36 ± 0.10 (0.014 ± 0.004)	0.20 ± 0.10 (0.008 ± 0.004)	0.64 REF (0.025 REF)	0.32 ± 0.10 (0.013 ± 0.004)

0508 - 2 Element

L	W	T	BW	BL	P	S
1.30 ± 0.15 (0.051 ± 0.006)	2.10 ± 0.15 (0.083 ± 0.006)	0.94 MAX (0.037 MAX)	0.43 ± 0.10 (0.017 ± 0.004)	0.33 ± 0.08 (0.013 ± 0.003)	1.00 REF (0.039 REF)	0.50 ± 0.10 (0.020 ± 0.004)

0508 - 4 Element

L	W	T	BW	BL	P	X	S
1.30 ± 0.15 (0.051 ± 0.006)	2.10 ± 0.15 (0.083 ± 0.006)	0.94 MAX (0.037 MAX)	0.25 ± 0.06 (0.010 ± 0.003)	0.20 ± 0.08 (0.008 ± 0.003)	0.50 REF (0.020 REF)	0.75 ± 0.10 (0.030 ± 0.004)	0.25 ± 0.10 (0.010 ± 0.004)

0612 - 4 Element

L	W	T	BW	BL	P	X	S
1.60 ± 0.20 (0.063 ± 0.008)	3.20 ± 0.20 (0.126 ± 0.008)	1.35 MAX (0.053 MAX)	0.41 ± 0.10 (0.016 ± 0.004)	0.18 ± 0.08 (0.007 ± 0.003)	0.76 REF (0.030 REF)	1.14 ± 0.10 (0.045 ± 0.004)	0.38 ± 0.10 (0.015 ± 0.004)

PAD LAYOUT DIMENSIONS

0405 - 2 Element

A	B	C	D	E
0.46 (0.018)	0.74 (0.029)	1.20 (0.047)	0.30 (0.012)	0.64 (0.025)

0508 - 2 Element

A	B	C	D	E
0.68 (0.027)	1.32 (0.052)	2.00 (0.079)	0.16 (0.018)	1.00 (0.039)

0508 - 4 Element

A	B	C	D	E
0.56 (0.022)	1.32 (0.052)	1.88 (0.074)	0.30 (0.012)	0.50 (0.020)

0612 - 4 Element

A	B	C	D	E
0.89 (0.035)	1.65 (0.065)	2.54 (0.100)	0.46 (0.018)	0.76 (0.030)

Introduction

As switching speeds increase and pulse rise times decrease the need to reduce inductance becomes a serious limitation for improved system performance. Even the decoupling capacitors, that act as a local energy source, can generate unacceptable voltage spikes: $V = L (di/dt)$. Thus, in high speed circuits, where di/dt can be quite large, the size of the voltage spike can only be reduced by reducing L .

Figure 1 displays the evolution of ceramic capacitor toward lower inductance designs over the last few years. AVX has been at the forefront in the design and manufacture of these newer more effective capacitors.

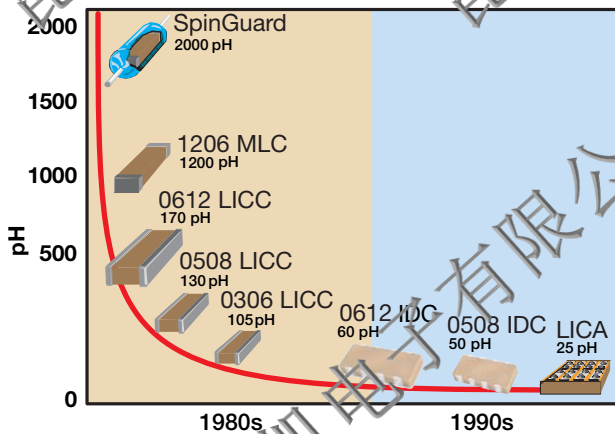

Figure 1. The evolution of Low Inductance Capacitors at AVX (values given for a 100 nF capacitor of each style)

LOW INDUCTANCE CHIP CAPACITORS

The total inductance of a chip capacitor is determined both by its length to width ratio and by the mutual inductance coupling between its electrodes. Thus a 1210 chip size has lower inductance than a 1206 chip. This design improvement is the basis of AVX's low inductance chip capacitors, LI Caps, where the electrodes are terminated on the long side of the chip instead of the short side. The 1206 becomes an 0612 as demonstrated in Figure 2. In the same manner an 0805 becomes an 0508 and 0603 becomes an 0306. This results in a reduction in inductance from around 1200 pH for conventional MLC chips to below 200 pH for Low Inductance Chip Capacitors. Standard designs and performance of these LI Caps are given on pages 55 and 56.

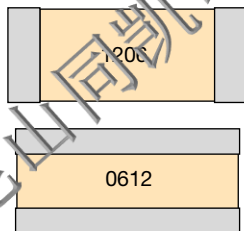
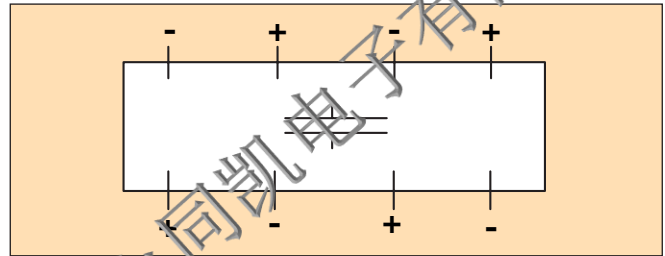

Figure 2. Change in aspect ratio: 1206 vs. 0612

INTERDIGITATED CAPACITORS

Multiple terminations of a capacitor will also help in reducing the parasitic inductance of the device. The IDC is such a device. By terminating one capacitor with 8 connections the ESL can be reduced even further. The measured inductance of the 0612 IDC is 60 pH, while the 0508 comes in around 50 pH. These FR4 mountable devices allow for even higher clock speeds in a digital decoupling scheme. Design and product offerings are shown on pages 59 and 60.



LOW INDUCTANCE CHIP ARRAYS (LICA®)

Further reduction in inductance can be achieved by designing alternative current paths to minimize the mutual inductance factor of the electrodes (Figure 3). This is achieved by AVX's LICA® product which was the result of a joint development between AVX and IBM. As shown in Figure 4, the charging current flowing out of the positive plate returns in the opposite direction along adjacent negative plates. This minimizes the mutual inductance.

The very low inductance of the LICA capacitor stems from the short aspect ratio of the electrodes, the arrangement of the tabs so as to cancel inductance, and the vertical aspect of the electrodes to the mounting surface.

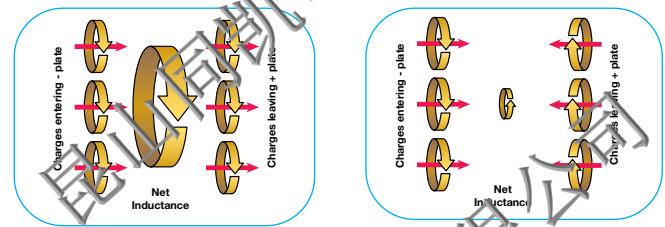

Figure 3. Net Inductance from design. In the standard Multilayer capacitor, the charge currents entering and leaving the capacitor create complementary flux fields, so the net inductance is greater. On the right, however, if the design permits the currents to be opposed, there is a net cancellation, and the inductance is much lower.

Low Inductance Capacitors



Introduction

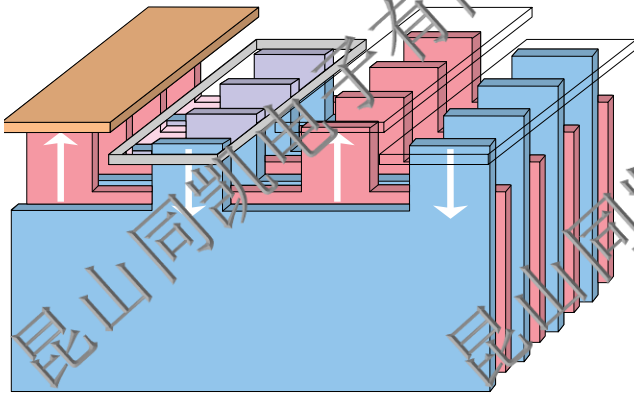

Figure 4. LICA's Electrode/Termination Construction. The current path is minimized – this reduces self-inductance. Current flowing out of the positive plate, returns in the opposite direction along the adjacent negative plate this reduces the mutual inductance.

Also the effective current path length is minimized because the current does not have to travel the entire length of both electrodes to complete the circuit. This reduces the self inductance of the electrodes. The self inductance is also minimized by the fact that the charging current is supplied by both sets of terminals reducing the path length even further!

The inductance of this arrangement is less than 30 pH, causing the self-resonance to be above 100 MHz for the same popular 100 nF capacitance. Parts available in the LICA design are shown on pages 60 and 61.

Figure 5 compares the self resonant frequencies of various capacitor designs versus capacitance values. The approximate inductance of each style is also shown.

Active development continues on low inductance capacitors. C4 termination with low temperature solder is now available for plastic packages. Consult AVX for details.

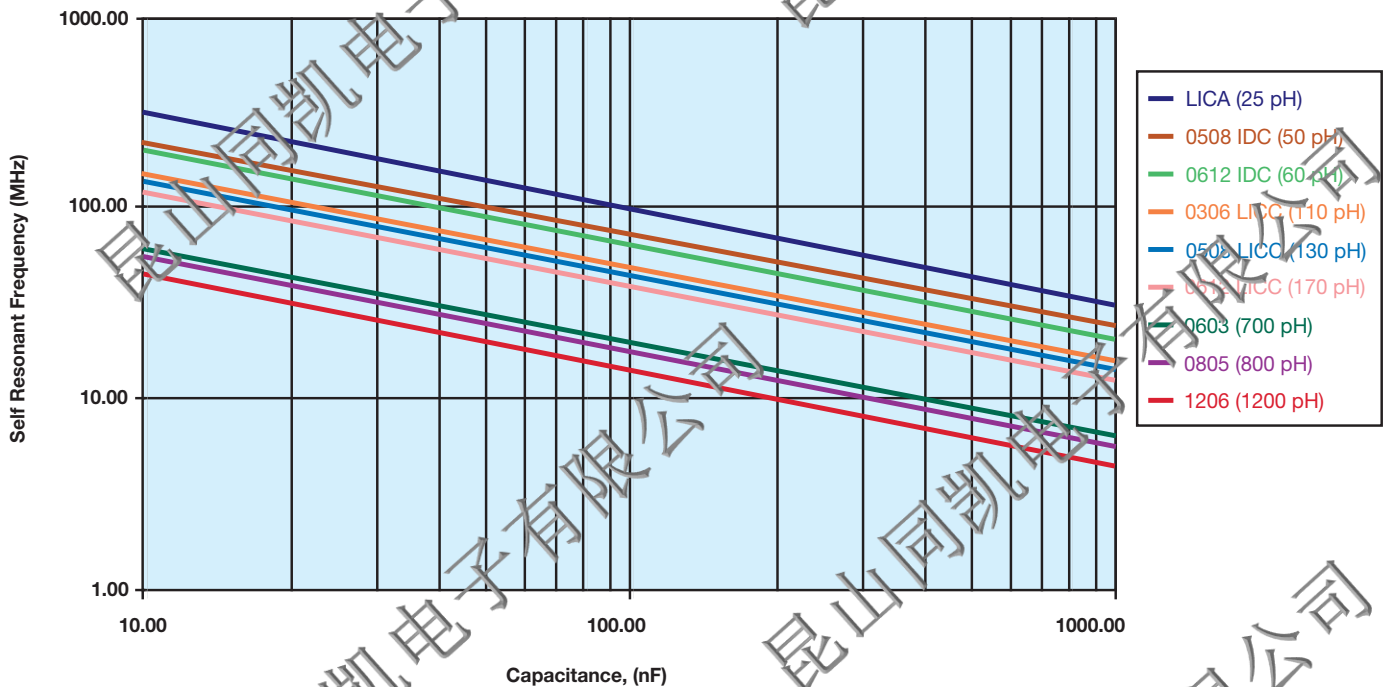

Figure 5. Self Resonant Frequency vs. Capacitance and Capacitor Design

Low Inductance Capacitors (RoHS)



0612/0508/0306 LICC (Low Inductance Chip Capacitors)

GENERAL DESCRIPTION

The total inductance of a chip capacitor is determined both by its length to width ratio and by the mutual inductance coupling between its electrodes.

Thus a 1210 chip size has a lower inductance than a 1206 chip. This design improvement is the basis of AVX's Low Inductance Chip Capacitors (LICC), where the electrodes are terminated on the long side of the chip instead of the short side. The 1206 becomes an 0612, in the same manner, an 0805 becomes an 0508, an 0603 becomes an 0306. This results in a reduction in inductance from the 1nH range found in normal chip capacitors to less than 0.2nH for LICCs. Their low profile is also ideal for surface mounting (both on the PCB and on IC package) or inside cavity mounting on the IC itself.

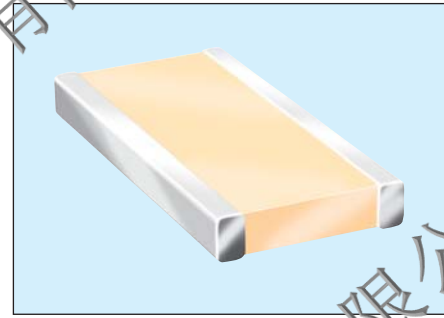

HOW TO ORDER

0612

Size
0306
0508
0612

Z

Voltage
6 = 6.3V
Z = 10V
Y = 16V
3 = 25V
5 = 50V

D

Dielectric
C = X7R
D = X5R

105

Capacitance Code (In pF)
2 Sig. Digits + Number of Zeros

M

Capacitance Tolerance
K = $\pm 10\%$
M = $\pm 20\%$

A

Failure Rate
A = M/A

T

Terminations
T = Plated Ni and Sn

2

Packaging Available
2 = 7" Reel
4 = 13" Reel

A*

Thickness
Thickness mm (in)
0.56 (0.022)
0.61 (0.024)
0.76 (0.030)
1.02 (0.040)
1.27 (0.050)

NOTE: Contact factory for availability, or Termination and Tolerance Options for Specific Part Numbers.

PERFORMANCE CHARACTERISTICS

Capacitance Tolerances	K = $\pm 10\%$; M = $\pm 20\%$
Operation Temperature Range	X7R = -55°C to +125°C; X5R = -55°C to +85°C
Temperature Coefficient	$\pm 15\%$ (0VDC)
Voltage Ratings	6.3, 10, 16, 25 VDC
Dissipation Factor	6.3V = 6.5% max; 10V = 5.0% max; 16V = 3.5% max; 25V = 3.0% max
Insulation Resistance (@+25°C, RVDC)	100,000M Ω min, or 1,000M Ω per μ F min., whichever is less

TYPICAL INDUCTANCE

Package Style	Measured Inductance (pH)
1206 MLCC	1200
0612 LICC	170
0508 LICC	130
0306 LICC	105

*Note: See Range Chart for Codes

TYPICAL IMPEDANCE CHARACTERISTICS

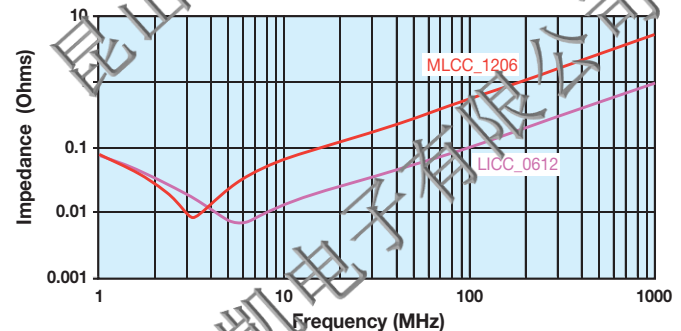
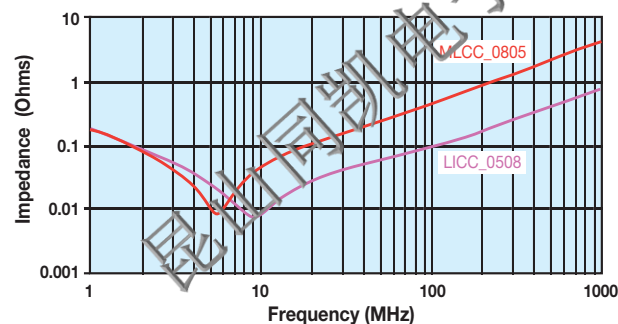

Low Inductance Capacitors (RoHS)



0612/0508/0306 LICC (Low Inductance Chip Capacitors)

SIZE	0306					0508					0612				
Packaging	Embossed					Embossed					Embossed				
Length	MM (in.)					MM (in.)					MM (in.)				
Width	MM (in.)					MM (in.)					MM (in.)				
WVDC	6.3	10	16	25	50	6.3	10	16	25	50	6.3	10	16	25	50
CAP	0.001					0.001					0.001				
(μ F)	0.0022					0.0022					0.0022				
	0.0047					0.0047					0.0047				
	0.010					0.010					0.010				
	0.015					0.015					0.015				
	0.022					0.022					0.022				
	0.047					0.047					0.047				
	0.068					0.068					0.068				
	0.10					0.10					0.10				
	0.15					0.15					0.15				
	0.22					0.22					0.22				
	0.47					0.47					0.47				
	0.68					0.68					0.68				
	1.0					1.0					1.0				
	1.5					1.5					1.5				
	2.2					2.2					2.2				
	3.3					3.3					3.3				
	4.7					4.7					4.7				
	10					10					10				

PHYSICAL DIMENSIONS AND PAD LAYOUT

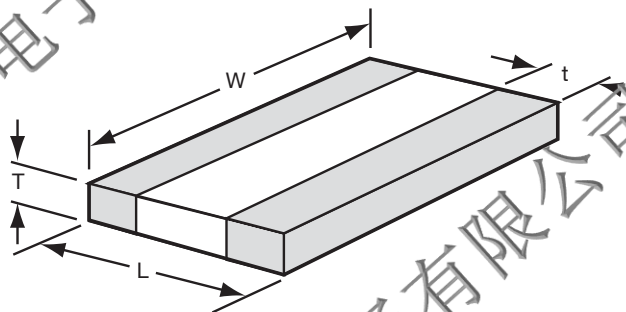

PHYSICAL CHIP DIMENSIONS

	L	W	t
0612	1.60 ± 0.25 (0.063 ± 0.010)	3.20 ± 0.25 (0.126 ± 0.010)	0.13 min. (0.005 min.)
0508	1.27 ± 0.25 (0.050 ± 0.010)	2.00 ± 0.25 (0.080 ± 0.010)	0.13 min. (0.005 min.)
0306	0.81 ± 0.15 (0.032 ± 0.006)	1.60 ± 0.15 (0.063 ± 0.006)	0.13 min. (0.005 min.)

T - See Range Chart for Thickness and Codes

PAD LAYOUT DIMENSIONS

	A	B	C
0612	0.76 (0.030)	3.05 (0.120)	.635 (0.025)
0508	0.51 (0.020)	2.03 (0.080)	0.51 (0.020)
0306	0.31 (0.012)	1.52 (0.060)	0.31 (0.012)

Solid = X7R = X5R

0306	
Code	Thickness
A	0.61 (0.024)

0508	
Code	Thickness
S	0.56 (0.022)
V	0.76 (0.030)
A	1.02 (0.040)

0612	
Code	Thickness
S	0.56 (0.022)
V	0.76 (0.030)
W	1.02 (0.040)
A	1.27 (0.050)

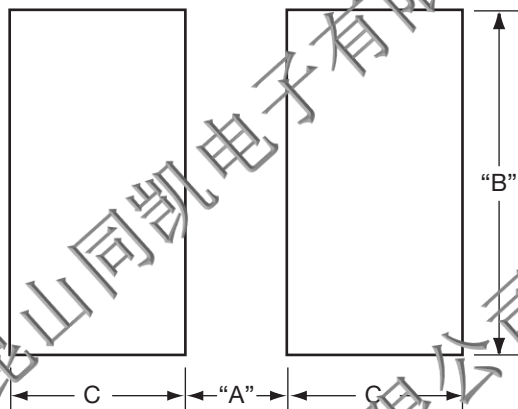

Low Inductance Capacitors (SnPb)



0612/0508/0306 X7R & X5R Dielectric – Tin Lead Termination

GENERAL DESCRIPTION

The total inductance of a chip capacitor is determined both by its length to width ratio and by the mutual inductance coupling between its electrodes.

Thus a 1210 chip size has a lower inductance than a 1206 chip. This design improvement is the basis of AVX's Low Inductance Chip Capacitors (LICC), where the electrodes are terminated on the long side of the chip instead of the short side. The 1206 becomes an 0612 in the same manner, an 0805 becomes an 0508, an 0603 becomes an 0306. This results in a reduction in inductance from the 1nH range found in normal chip capacitors to less than 0.2nH for LICCs. Their low profile is also ideal for surface mounting (both on the PCB and on IC package) or inside cavity mounting on the IC itself.

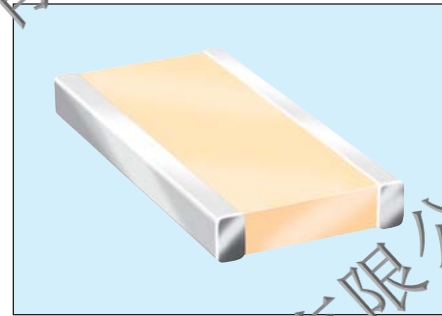

HOW TO ORDER

LD18

Size
LD16
LD17
LD18

Z

Voltage
6 = 6.3V
Z = 10V
Y = 16V
3 = 25V
5 = 50V

D

Dielectric
C = X7R
D = X5R

105

Capacitance Code (In pF)
2 Sig. Digits + Number of Zeros

M

Capacitance Tolerance
K = ±10%
M = ±20%

A

Failure Rate
A = N/A

B

Terminations
B = 5% min lead

2

Packaging Available
2 = 7" Reel
4 = 13" Reel

A*

Thickness
Thickness
mm (in)
0.56 (0.022)
0.61 (0.024)
0.76 (0.030)
1.02 (0.040)
1.27 (0.050)

NOTE: Contact factory for availability of Termination and Tolerance Options for Specific Part Numbers.

Low Inductance Capacitors (SnPb)



0612/0508/0306 X7R & X5R Dielectric –
Tin Lead Termination

PREFERRED SIZES ARE SHADED

SIZE	LD16					LD17					LD18				
Soldering	Reflow Only					Reflow Only					Reflow/Wave				
Packaging	All Paper					All Paper					Paper/Embossed				
(L) Length (mm)	0.81 ± 0.15 (0.032 ± 0.006)					1.27 ± 0.25 (0.050 ± 0.010)					1.60 ± 0.25 (0.063 ± 0.010)				
(W) Width (mm)	1.60 ± 0.15 (0.063 ± 0.006)					2.00 ± 0.25 (0.080 ± 0.010)					3.20 ± 0.25 (0.126 ± 0.010)				
WVDC	6.3	10	16	25	50	6.3	10	16	25	50	6.3	10	16	25	50
Cap (pF)	1000	A	A	A	A	S	S	S	S	V	S	S	S	S	V
	2200	A	A	A	A	S	S	S	S	V	S	S	S	S	V
	4700	A	A	A	A	S	S	S	S	V	S	S	S	S	V
Cap (µF)	0.010	A	A	A	A	S	S	S	S	V	S	S	S	S	V
	0.015	A	A	A	A	S	S	S	S	V	S	S	S	S	W
	0.022	A	A	A	A	S	S	S	S	V	S	S	S	S	W
	0.047	A	A	A		S	S	S	V	A	S	S	S	S	W
	0.068	A	A	A		S	S	S	A	A	S	S	S	V	W
	0.10	A	A	A		S	S	V	A	A	S	S	S	V	W
	0.15	A	A			S	S	V			S	S	S	W	W
	0.22	A	A			S	S	A			S	S	V		
	0.47					S	V	A			S	V			
	0.68					A	A				V	V	W		
	1.0					A	A				V	V	A		
	1.5										W	W			
	2.2										A	A			
	3.3														
	4.7														
	10														
WVDC	6.3	10	16	25	50	6.3	10	16	25	50	6.3	10	16	25	50
SIZE	0306					0508					0612				

0306		0508		0612	
Code	Thickness	Code	Thickness	Code	Thickness
A	0.61 (0.024)	S	0.56 (0.022)	S	0.56 (0.022)
		V	0.76 (0.030)	V	0.76 (0.030)
		A	1.02 (0.040)	W	1.02 (0.040)
				A	1.27 (0.050)

Solid = X7R



= X5R

IDC Low Inductance Capacitors (RoHS)

0612/0508 IDC (InterDigitated Capacitors)

GENERAL DESCRIPTION

- Very low equivalent series inductance (ESL), surface mountable, high speed decoupling capacitor in 0612 and 0508 case size.
- Measured inductances of 60 pH (for 0612) and 50 pH (for 0508), are the lowest in the FR4 mountable device family. Now use 10T devices with inductances of 45 pH (for 0612) and 35 pH (for 0508).
- Opposing current flow creates opposing magnetic fields. This causes the fields to cancel, effectively reducing the equivalent series inductance.
- Perfect solution for decoupling high speed microprocessors by allowing the engineers to lower the power delivery inductance of the entire system through the use of eight vias.
- Overall reduction in decoupling components due to very low series inductance and high capacitance.

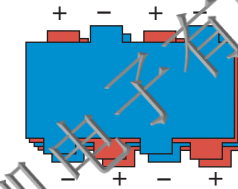

HOW TO ORDER

W	3	L	1	6	D	225	M	A	T	3	A
Style	Case Size	Low Inductance	Number of Terminals	Voltage	Dielectric	Capacitance Code (In pF)	Capacitance Tolerance	Failure Rate	Termination	Packaging Available	Thickness
	2 = 0508 3 = 0612	ESL = 50pH ESL = 60pH	1 = 8 Terminals	4 = 4V 6 = 6.3V Z = 10V Y = 16V	C = X7R D = X5R	2 Sig. Digits + Number of Zeros	M = ±20%	A = N/A	T = Plated Ni and Sn	1=7" Reel 3=13" Reel	Max. Thickness mm (in.) A=0.95 (0.037) S=0.55 (0.022)

NOTE: Contact factory for availability of Termination and Tolerance Options for Specific Part Numbers.

PERFORMANCE CHARACTERISTICS

Capacitance Tolerance	±20% Preferred
Operation Temperature Range	X7R = -55°C to +125°C; X5R = -55°C to +85°C
Temperature Coefficient	±15% (0VDC)
Voltage Ratings	4, 6.3, 10, 16 VDC
Dissipation Factor	4V, 6.3V = 6.5% max; 10V = 5.0% max; 16V = 3.5% max
Insulation Resistance (@+25°C, RVDC)	100,000MΩ min, or 1,000MΩ per μF min., whichever is less

Dielectric Strength	No problems observed after 2.5 x RVDC for 5 seconds at 50mA max current
CTE (ppm/C)	12.0
Thermal Conductivity	4-5W/M K
Terminations Available	Plated Nickel and Solder
Max. Thickness	0.037" (0.95mm)

TYPICAL ESL AND IMPEDANCE

Package Style	Measured Inductance (pH)
1206 MLCC	1200
0612 LCC	170
0612 IDC	60
0508 IDC	50

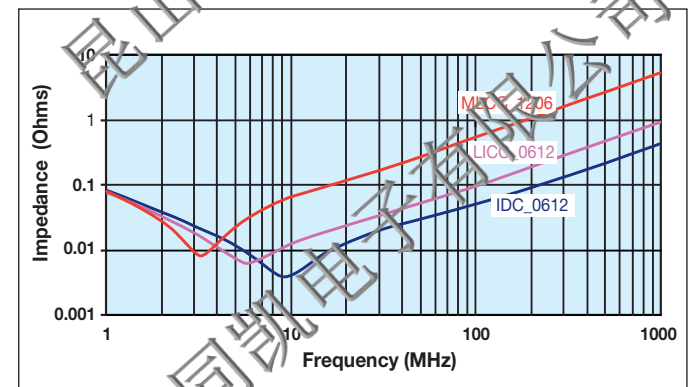

IDC Low Inductance Capacitors (RoHS) **AVX**

0612/0508 IDC (InterDigitated Capacitors)

SIZE		0508				0612																																																																																																																																																																																																																	
Length	MM (in.)	2.03 ± 0.20 (0.080 ± 0.008)				3.20 ± 0.20 (0.126 ± 0.008)																																																																																																																																																																																																																	
Width	MM (in.)	1.27 ± 0.20 (0.050 ± 0.008)				1.60 ± 0.20 (0.063 ± 0.008)																																																																																																																																																																																																																	
Terminal Pitch	MM (in.)	0.50 ± 0.05 (0.020 ± 0.002)				0.80 ± 0.10 (0.031 ± 0.004)																																																																																																																																																																																																																	
Thickness	MM (in.)	0.25 MAX. (0.022) MAX.				0.95 MAX. (0.037) MAX.																																																																																																																																																																																																																	
WVDC		4	6.3	10	16	4	6.3	10	16	4	6.3	10	16	4	6.3	10	16																																																																																																																																																																																																						
CAP (µF) and Thickness		<table border="1"> <tr><td>0.047</td><td></td><td></td><td></td><td></td><td></td><td></td><td></td><td></td><td></td><td></td><td></td><td></td><td></td><td></td><td></td><td></td><td></td></tr> <tr><td>0.068</td><td></td><td></td><td></td><td></td><td></td><td></td><td></td><td></td><td></td><td></td><td></td><td></td><td></td><td></td><td></td><td></td><td></td></tr> <tr><td>0.10</td><td></td><td></td><td></td><td></td><td></td><td></td><td></td><td></td><td></td><td></td><td></td><td></td><td></td><td></td><td></td><td></td><td></td></tr> <tr><td>0.22</td><td></td><td></td><td></td><td></td><td></td><td></td><td></td><td></td><td></td><td></td><td></td><td></td><td></td><td></td><td></td><td></td><td></td></tr> <tr><td>0.33</td><td></td><td></td><td></td><td></td><td></td><td></td><td></td><td></td><td></td><td></td><td></td><td></td><td></td><td></td><td></td><td></td><td></td></tr> <tr><td>0.47</td><td></td><td></td><td></td><td></td><td></td><td></td><td></td><td></td><td></td><td></td><td></td><td></td><td></td><td></td><td></td><td></td><td></td></tr> <tr><td>0.68</td><td></td><td></td><td></td><td></td><td></td><td></td><td></td><td></td><td></td><td></td><td></td><td></td><td></td><td></td><td></td><td></td><td></td></tr> <tr><td>1.0</td><td></td><td></td><td></td><td></td><td></td><td></td><td></td><td></td><td></td><td></td><td></td><td></td><td></td><td></td><td></td><td></td><td></td></tr> <tr><td>1.5</td><td></td><td></td><td></td><td></td><td></td><td></td><td></td><td></td><td></td><td></td><td></td><td></td><td></td><td></td><td></td><td></td><td></td></tr> <tr><td>2.2</td><td></td><td></td><td></td><td></td><td></td><td></td><td></td><td></td><td></td><td></td><td></td><td></td><td></td><td></td><td></td><td></td><td></td></tr> <tr><td>3.3</td><td></td><td></td><td></td><td></td><td></td><td></td><td></td><td></td><td></td><td></td><td></td><td></td><td></td><td></td><td></td><td></td><td></td></tr> </table>																0.047																		0.068																		0.10																		0.22																		0.33																		0.47																		0.68																		1.0																		1.5																		2.2																		3.3																	
0.047																																																																																																																																																																																																																							
0.068																																																																																																																																																																																																																							
0.10																																																																																																																																																																																																																							
0.22																																																																																																																																																																																																																							
0.33																																																																																																																																																																																																																							
0.47																																																																																																																																																																																																																							
0.68																																																																																																																																																																																																																							
1.0																																																																																																																																																																																																																							
1.5																																																																																																																																																																																																																							
2.2																																																																																																																																																																																																																							
3.3																																																																																																																																																																																																																							

Consult factory for additional requirements

= X7R
 = X5R

PHYSICAL DIMENSIONS AND PAD LAYOUT

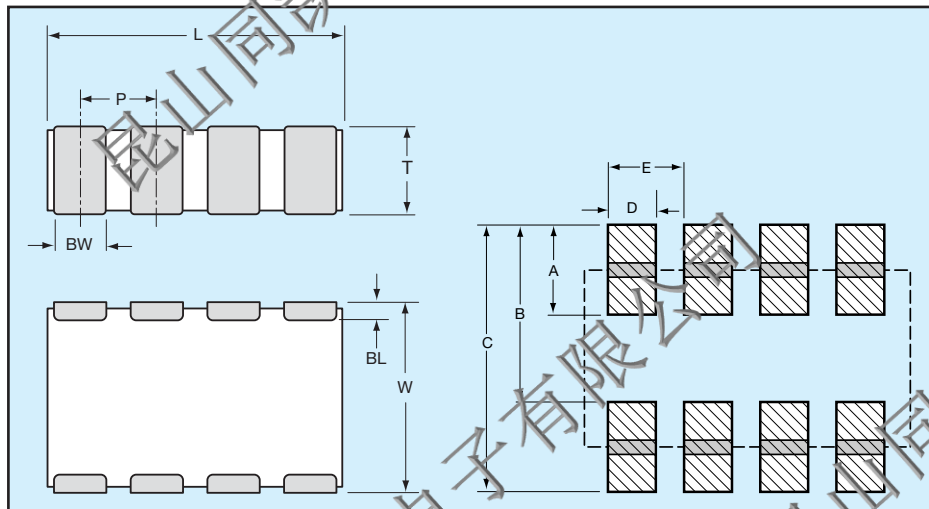

PHYSICAL CHIP DIMENSIONS millimeters (inches)

0612

L	W	BW	BL	P
3.20 ± 0.20 (0.126 ± 0.008)	1.60 ± 0.20 (0.063 ± 0.008)	0.41 ± 0.10 (0.016 ± 0.004)	0.18 ^{+0.25} _{-0.08} (0.007 ^{+0.010} _{-0.003})	0.80 ± 0.10 (0.031 ± 0.004)

0508

L	W	BW	BL	P
2.03 ± 0.20 (0.080 ± 0.008)	1.27 ± 0.20 (0.050 ± 0.008)	0.254 ± 0.10 (0.010 ± 0.004)	0.18 ^{+0.25} _{-0.08} (0.007 ^{+0.010} _{-0.003})	0.50 ± 0.05 (0.020 ± 0.002)

PAD LAYOUT DIMENSIONS

0612

A	B	C	D	E
0.89 (0.035)	1.65 (0.065)	2.54 (0.100)	0.46 (0.018)	0.80 (0.031)

0508

A	B	C	D	E
0.64 (0.025)	1.27 (0.050)	1.91 (0.075)	0.28 (0.011)	0.50 (0.020)

IDC Low Inductance Capacitors (SnPb)

0612/0508 IDC with Sn/Pb Termination

GENERAL DESCRIPTION

AVX will support those customers who desire commercial and military type ceramic capacitors with a new series consisting of a termination with a 5% minimum lead content. This new series is AVX's "LD" series incorporating a "B" in the 12th position of the AVX Catalog Part Number. This fulfills AVX's commitment to providing a full range of products.

- Very low equivalent series inductance (ESL), surface mountable, high speed decoupling capacitor in 0612 and 0508 case size.
- Measured inductances of 60 pH (for 0612) and 50 pH (for 0508) are the lowest in the FR4 mountable device family. Now use 10T devices with inductances of 45 pH (for 0612) and 35 pH (for 0508).
- Opposing current flow creates opposing magnetic fields. This causes the fields to cancel, effectively reducing the equivalent series inductance.
- Perfect solution for decoupling high speed microprocessors by allowing the engineers to lower the power delivery inductance of the entire system through the use of eight vias.
- Overall reduction in decoupling components due to very low series inductance and high capacitance.

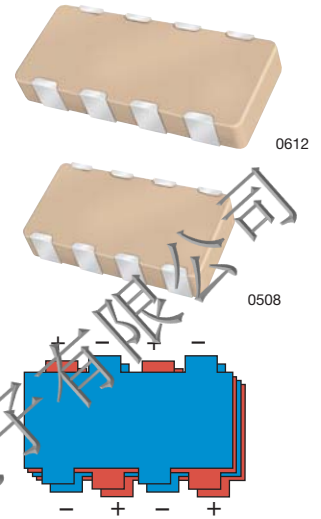

HOW TO ORDER

L	3	L	1	6	D	225	M	A	B	3	A
Style	Case Size	Low Inductance	Number of Terminals	Voltage	Dielectric	Capacitance Code (in pF)	Capacitance Tolerance	Failure Rate	Termination	Packaging Available	Thickness
	2 = 0508 3 = 0612	ESL = 50pH ESL = 60pH	7 = 8 Terminals	4 = 4V 6 = 6.3V Z = 10V Y = 16V	C = X7R D = X5R	2 Sig. Digits + Number of Zeros	M = ±20%	A = N/A	B = 5% min. Lead	1=7" Reel 3=13" Reel	Max. Thickness mm (in.) A=0.95 (0.037) S=0.55 (0.022)

NOTE: Contact factory for availability of Termination and Tolerance Options for Specific Part Numbers.

PERFORMANCE CHARACTERISTICS

Capacitance Tolerance	±20% Preferred
Operation Temperature Range	X7R = -55°C to +125°C; X5R = -55°C to +85°C
Temperature Coefficient	±15% (0VDC)
Voltage Ratings	4, 6.3, 10, 16 VDC
Dissipation Factor	4V, 6.3V = 6.5% max; 10V = 5.0% max; 16V = 3.5% max
Insulation Resistance (@+25°C, RVDC)	100,000MΩ min, or 1,000MΩ per μF min., whichever is less

Dielectric Strength	No problems observed after 2.5 x RVDC for 5 seconds at 50mA max current
CTE (ppm/C)	12.0
Thermal Conductivity	4-5W/M K
Terminations Available	Plated Nickel and 5% min. Lead
Max. Thickness	0.037" (0.95mm)

TYPICAL ESL AND IMPEDANCE

Package Style	Measured inductance (pH)
1206 MLCC	1200
0612 LCC	170
0612 IDC	60
0508 IDC	50

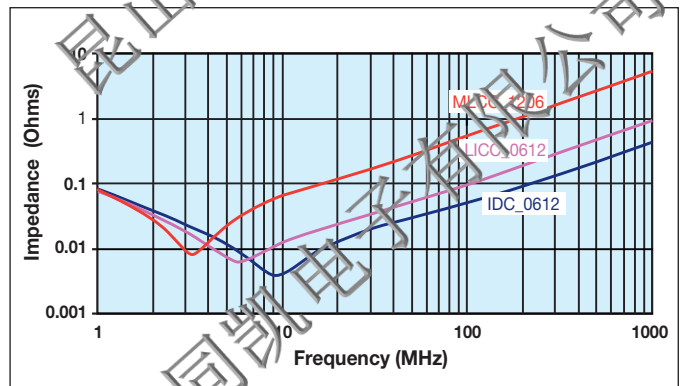

IDC Low Inductance Capacitors (SnPb) **AVX**

0612/0508 IDC with Sn/Pb Termination

SIZE	Thin 0508				0508				Thin 0612				0612																																																																																																																																																																																														
Length	MM (in.) 2.03 ± 0.20 (0.080 ± 0.008)				2.03 ± 0.20 (0.080 ± 0.008)				3.20 ± 0.20 (0.126 ± 0.008)				3.20 ± 0.20 (0.126 ± 0.008)																																																																																																																																																																																														
Width	1.27 ± 0.20 (0.050 ± 0.008)				1.27 ± 0.20 (0.050 ± 0.008)				1.60 ± 0.20 (0.063 ± 0.008)				1.60 ± 0.20 (0.063 ± 0.008)																																																																																																																																																																																														
Terminal Pitch	0.50 ± 0.05 (0.020 ± 0.002)				0.50 ± 0.05 (0.020 ± 0.002)				0.80 ± 0.10 (0.031 ± 0.004)				0.80 ± 0.10 (0.031 ± 0.004)																																																																																																																																																																																														
Thickness	0.25 MAX. (0.022) MAX.				0.95 MAX. (0.037) MAX.				0.55 MAX. (0.032) MAX.				0.95 MAX. (0.037) MAX.																																																																																																																																																																																														
WVDC	4	6.3	10	16	4	6.3	10	16	4	6.3	10	16	4	6.3	10	16																																																																																																																																																																																											
CAP (µF) and Thickness	<table border="1"> <tr> <td>0.047</td> <td></td><td></td><td></td><td></td><td></td><td></td><td></td><td></td><td></td><td></td><td></td><td></td><td></td><td></td><td></td><td></td> </tr> <tr> <td>0.068</td> <td></td><td></td><td></td><td></td><td></td><td></td><td></td><td></td><td></td><td></td><td></td><td></td><td></td><td></td><td></td><td></td> </tr> <tr> <td>0.10</td> <td></td><td></td><td></td><td></td><td></td><td></td><td></td><td></td><td></td><td></td><td></td><td></td><td></td><td></td><td></td><td></td> </tr> <tr> <td>0.22</td> <td></td><td></td><td></td><td></td><td></td><td></td><td></td><td></td><td></td><td></td><td></td><td></td><td></td><td></td><td></td><td></td> </tr> <tr> <td>0.33</td> <td></td><td></td><td></td><td></td><td></td><td></td><td></td><td></td><td></td><td></td><td></td><td></td><td></td><td></td><td></td><td></td> </tr> <tr> <td>0.47</td> <td></td><td></td><td></td><td></td><td></td><td></td><td></td><td></td><td></td><td></td><td></td><td></td><td></td><td></td><td></td><td></td> </tr> <tr> <td>0.68</td> <td></td><td></td><td></td><td></td><td></td><td></td><td></td><td></td><td></td><td></td><td></td><td></td><td></td><td></td><td></td><td></td> </tr> <tr> <td>1.0</td> <td></td><td></td><td></td><td></td><td></td><td></td><td></td><td></td><td></td><td></td><td></td><td></td><td></td><td></td><td></td><td></td> </tr> <tr> <td>1.5</td> <td></td><td></td><td></td><td></td><td></td><td></td><td></td><td></td><td></td><td></td><td></td><td></td><td></td><td></td><td></td><td></td> </tr> <tr> <td>2.2</td> <td></td><td></td><td></td><td></td><td></td><td></td><td></td><td></td><td></td><td></td><td></td><td></td><td></td><td></td><td></td><td></td> </tr> <tr> <td>3.3</td> <td></td><td></td><td></td><td></td><td></td><td></td><td></td><td></td><td></td><td></td><td></td><td></td><td></td><td></td><td></td><td></td> </tr> </table>																0.047																	0.068																	0.10																	0.22																	0.33																	0.47																	0.68																	1.0																	1.5																	2.2																	3.3																
0.047																																																																																																																																																																																																											
0.068																																																																																																																																																																																																											
0.10																																																																																																																																																																																																											
0.22																																																																																																																																																																																																											
0.33																																																																																																																																																																																																											
0.47																																																																																																																																																																																																											
0.68																																																																																																																																																																																																											
1.0																																																																																																																																																																																																											
1.5																																																																																																																																																																																																											
2.2																																																																																																																																																																																																											
3.3																																																																																																																																																																																																											

Consult factory for additional requirements

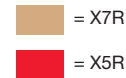

PHYSICAL DIMENSIONS AND PAD LAYOUT

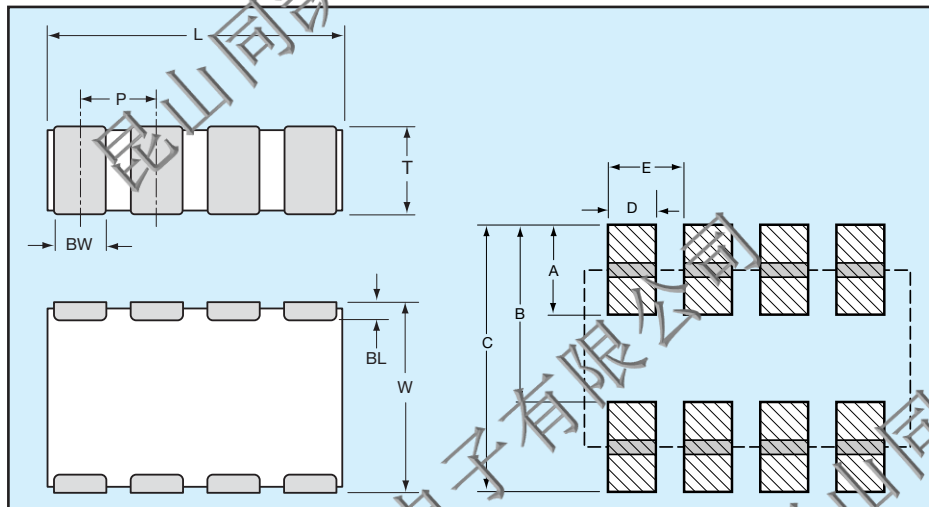

PHYSICAL CHIP DIMENSIONS millimeters (inches)

0612

L	W	BW	BL	P
3.20 ± 0.20 (0.126 ± 0.008)	1.60 ± 0.20 (0.063 ± 0.008)	0.41 ± 0.10 (0.016 ± 0.004)	0.18 ^{+0.25} _{-0.08} (0.007 ^{+0.010} _{-0.003})	0.80 ± 0.10 (0.031 ± 0.004)

0508

L	W	BW	BL	P
2.03 ± 0.20 (0.080 ± 0.008)	1.27 ± 0.20 (0.050 ± 0.008)	0.254 ± 0.10 (0.010 ± 0.004)	0.18 ^{+0.25} _{-0.08} (0.007 ^{+0.010} _{-0.003})	0.50 ± 0.05 (0.020 ± 0.002)

PAD LAYOUT DIMENSIONS

0612

A	B	C	D	E
0.89 (0.035)	1.65 (0.065)	2.54 (0.100)	0.46 (0.018)	0.80 (0.031)

0508

A	B	C	D	E
0.64 (0.025)	1.27 (0.050)	1.91 (0.075)	0.28 (0.011)	0.50 (0.020)

Low Inductance Capacitors



LICA® (Low Inductance Decoupling Capacitor Arrays)

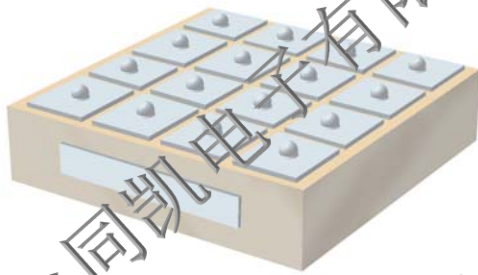

LICA® arrays utilize up to four separate capacitor sections in one ceramic body (see Configurations and Capacitance Options). These designs exhibit a number of technical advancements:

Low Inductance features—

- Low resistance platinum electrodes in a low aspect ratio pattern
- Double electrode pickup and perpendicular current paths
- C4 “flip-chip” technology for minimal interconnect inductance

HOW TO ORDER

LICA	3	T	102	M	3	F	C	4	A	A
Style & Size	5V = 9 10V = Z 25V = 3	D = X5R T = T55T S = High K T55T	Cap/Section (EIA Code) 102 = 1000 pF 103 = 10 nF 104 = 100 nF	Capacitance Tolerance M = ±20% P = GMV	Height Code 6 = 0.500mm 3 = 0.650mm 1 = 0.875mm 5 = 1.100mm 7 = 1.600mm	Termination F = C4 Solder Balls- 97Pb/3Sn H = C4 Solder Balls L = Low ESR P = Cr-Cu-Au N = Cr-Ni-Au X = None	Reel Packaging M = 7" Reel R = 13" Reel 6 = 2"x2" Waffle Pack 8 = 2"x2" Black Waffle Pack 7 = 2"x2" Waffle Pack w/ termination facing up A = 2"x2" Black Waffle Pack w/ termination facing up G = 4"x4" Waffle Pack w/ clear lid	# of Caps/Part 1 = one 2 = two 4 = four	Inspection Code A = Standard B = Established Reliability Testing	Code Face A = Bar B = No Bar C = Dot, S55S Dielectrics D = Triangle

TABLE 1

Typical Parameters	T55T	Units
Capacitance, 25°C	Ck	Nanofarads
Capacitance, 55°C	1.4 x Co	Nanofarads
Capacitance, 85°C	0.7 x Co	Nanofarads
Dissipation Factor 25°	15	Percent
ESR	20	Megohms
DC Resistance	0.2	Ohms
IR (Minimum @25°)	2.0	Megaohms
Dielectric Breakdown, Min	500	Volts
Thermal Coefficient of Expansion	8.5	ppm/°C 25-100°
Inductance: (Design Dependent)	30	Pico-Henries
Frequency of Operation	DC to 5 Gigahertz	
Ambient Temp Range	-55° to 125°C	

NOTE: Contact factory for availability of Termination and Tolerance Options for Specific Part Numbers.

C4 AND PAD DIMENSIONS

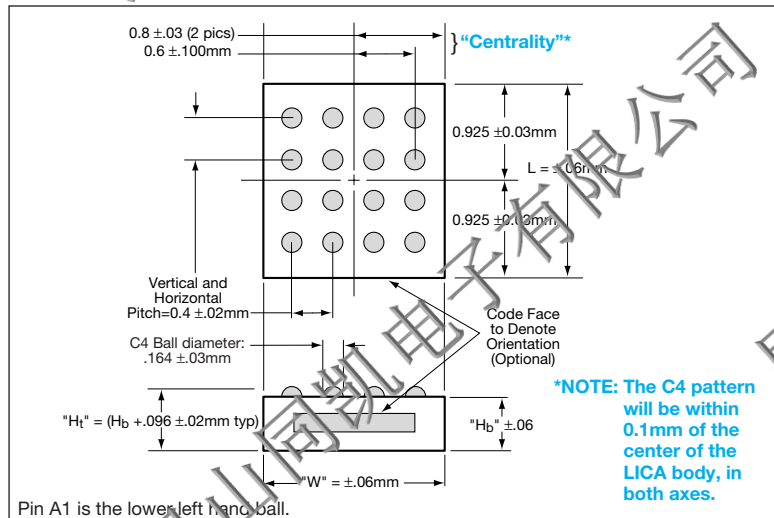

Pin A1 is the lower left hand ball.

Code (Body Height)	Width (W)	Length (L)	Height Body (H _b)
1	1.600mm	1.850mm	0.875mm
3	1.600mm	1.850mm	0.650mm
5	1.600mm	1.850mm	1.100mm
6	1.600mm	1.850mm	0.500mm
7	1.600mm	1.850mm	1.600mm

TERMINATION OPTIONS

C4 SOLDER (97% Pb/3% Sn) BALLS

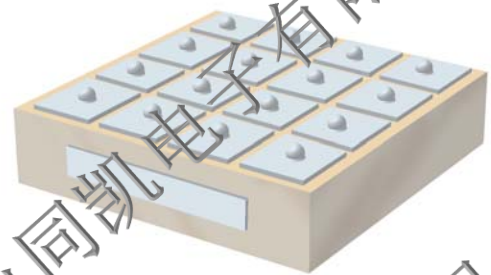

TERMINATION OPTION ORN

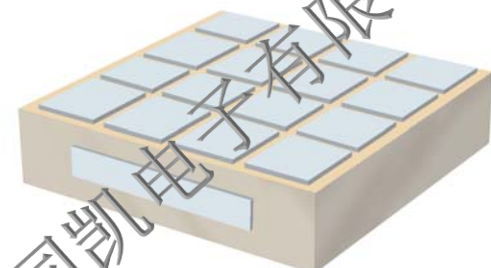

Low Inductance Capacitors



LICA® (Low Inductance Decoupling Capacitor Arrays)

LICA® TYPICAL PERFORMANCE CURVES

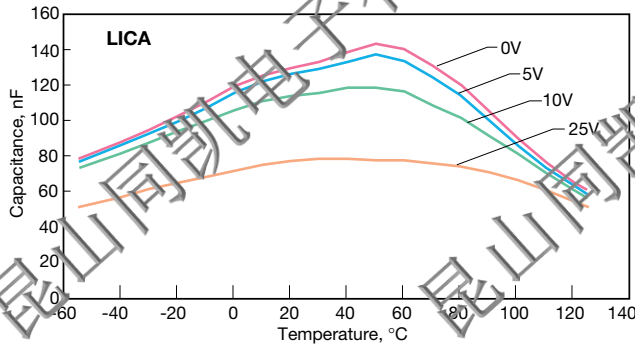

Effect of Bias Voltage and Temperature on a 130 nF LICA® (T55T)

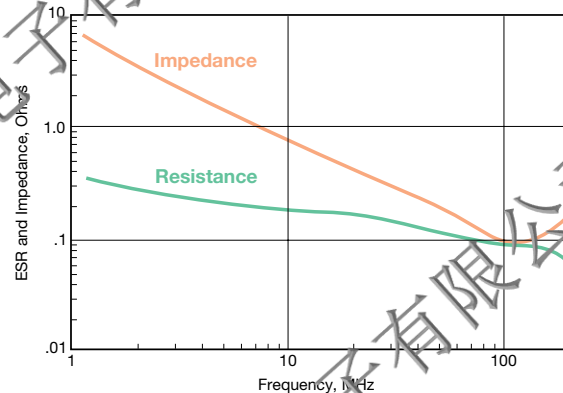

Impedance vs. Frequency

LICA VALID PART NUMBER LIST

Part Number	Voltage	Thickness (mm)	Capacitors per Package
LICA3T193M3FC4AA	25	0.650	4
LICA3T153P3FC4AA	25	0.650	4
LICA3T134M1FC1AA	25	0.875	1
LICA3T104P1FC1AA	25	0.875	1
LICA3T333M1FC4AA	25	0.875	4
LICA3T263P3FC4AA	25	0.650	4
LICA3T244M5FC1AA	25	1.100	1
LICA3T194P5FC1AA	25	1.100	1
LICA3T394M7FC1AB	25	1.600	1
LICA3T314P7FC1AB	25	1.600	1
Extended Range			
LICAZT623M3FC4AB	10	0.650	4
LICA3T104M3FC1A	25	0.650	1
LICA3T803P3FC1A	25	0.650	1
LICA3T503M3FC2A	25	0.650	2
LICA3T403P3FC2A	25	0.650	2
LICA3S253M3FC4A	25	0.650	4
LICAZD753M3FC4AD	10	0.650	4
LICAZD504M3FC1AB	10	0.650	4
LICAZD604M7FC1AB	10	1.600	4
LICA3D193M3FC4AB	25	0.650	4

CONFIGURATION

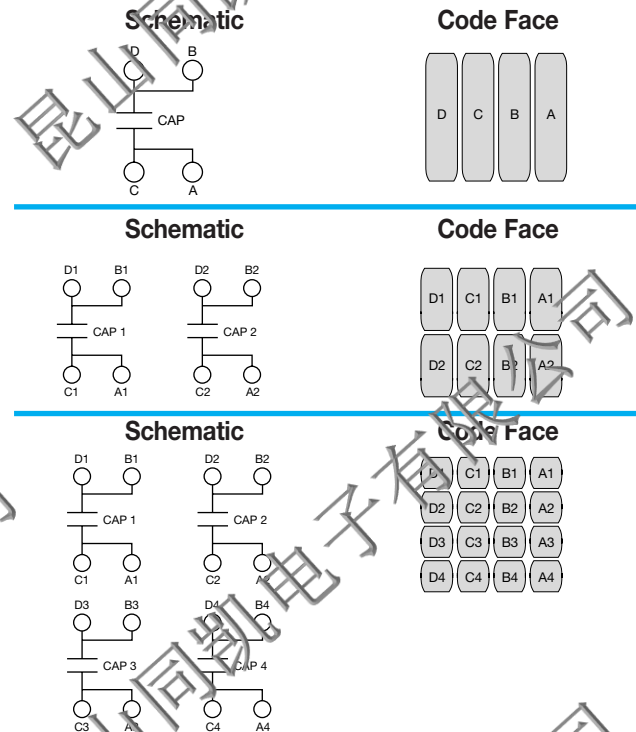

WAFFLE PACK OPTIONS FOR LICA®

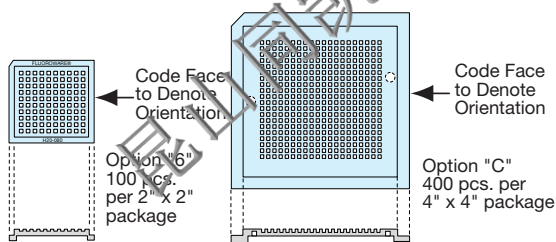

Note: Standard configuration is Termination side down

LICA® PACKAGING SCHEME "M" AND "R"

8mm conductive plastic tape on reel:
 "M"=7" reel max. qty. 3,000, "R"=13" reel max. qty. 8,000

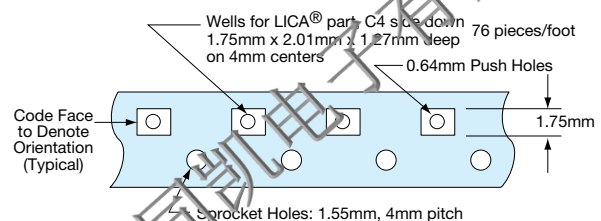

High Voltage MLC Chips

For 600V to 5000V Application

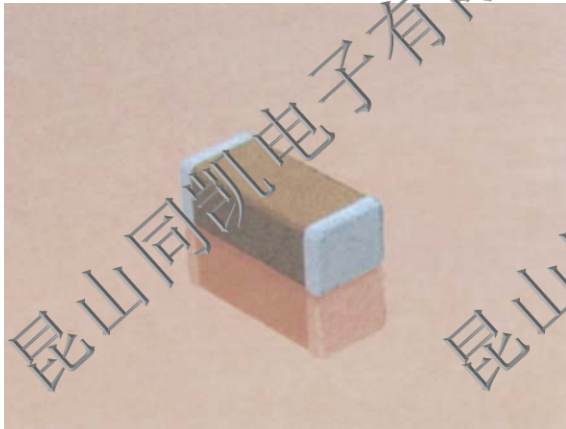

High value, low leakage and small size are difficult parameters to obtain in capacitors for high voltage systems. AVX special high voltage MLC chip capacitors meet these performance characteristics and are designed for applications such as snubbers in high frequency power converters, resonators in SMPS, and high voltage coupling/dc blocking. These high voltage chip designs exhibit low ESRs at high frequencies.

Larger physical sizes than normally encountered chips are used to make high voltage MLC chip products. Special precautions must be taken in applying these chips in surface mount assemblies. The temperature gradient during heating or cooling cycles should not exceed 4°C per second. The preheat temperature must be within 50°C of the peak temperature reached by the ceramic bodies through the soldering process. Chip sizes 1210 and larger should be reflow soldered only. Capacitors may require protective surface coating to prevent external arcing.

NEW 630V RANGE

HOW TO ORDER

1808	A	A	271	K	A	1	1	A
AVX Style	Voltage	Temperature Coefficient	Capacitance Code (2 significant digits + no. of zeros) Examples:	Capacitance Tolerance COG: J = ±5% K = ±10% X7R: K = ±10% M = ±20% Z = +80%, -20%	Test Level A = Standard	Termination* 1 = Pd/Ag T = Plated Ni and Sn (RoHS Compliant)	Packaging 1 = 7" Reel 3 = 13" Reel 9 = Bulk	Special Code A = Standard
0805	600V/630V = C 1000V = A 1500V = S 2000V = G 2500V = W 3000V = H 4000V = J 5000V = K	COG = A X7R = C	10 pF = 100 100 pF = 101 1,000 pF = 102 22,000 pF = 223 220,000 pF = 224 1 μF = 105					
1206								
1210								
1808								
1812								
1825								
2220								
2225								
3640								

*Note: Terminations with 5% minimum lead (Pb) is available, see pages 69 and 70 for LD style.

Notes: Capacitors with X7R dielectrics are not intended for applications across AC supply mains or AC line filtering with polarity reversal. Contact plant for recommendations. Contact factory for availability of Termination and Tolerance options for Specific Part Numbers.

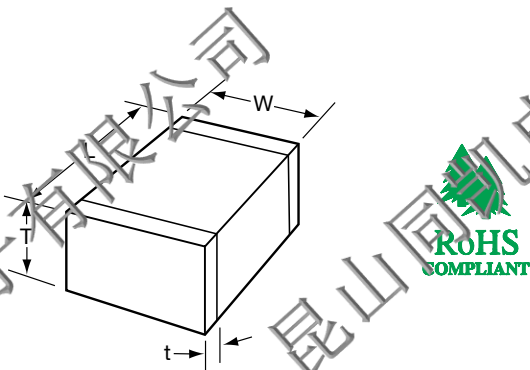

DIMENSIONS

SIZE	0805	1206	1210*	1808*	1812*	1825*	2220*	2225*	3640*
(L) Length	2.01 ± 0.20 (0.079 ± 0.008)	3.20 ± 0.20 (0.126 ± 0.008)	3.20 ± 0.20 (0.126 ± 0.008)	4.57 ± 0.25 (0.180 ± 0.010)	4.50 ± 0.30 (0.177 ± 0.012)	4.50 ± 0.30 (0.177 ± 0.012)	5.70 ± 0.49 (0.224 ± 0.019)	5.72 ± 0.25 (0.225 ± 0.010)	9.14 ± 0.25 (0.360 ± 0.010)
(W) Width	1.25 ± 0.20 (0.049 ± 0.008)	1.60 ± 0.20 (0.063 ± 0.008)	2.50 ± 0.20 (0.098 ± 0.008)	2.03 ± 0.25 (0.080 ± 0.010)	3.20 ± 0.20 (0.126 ± 0.008)	6.40 ± 0.30 (0.252 ± 0.012)	5.00 ± 0.40 (0.197 ± 0.016)	6.35 ± 0.25 (0.250 ± 0.010)	10.2 ± 0.25 (0.400 ± 0.010)
(T) Thickness Max.	1.30 (0.051)	1.52 (0.060)	1.70 (0.067)	2.03 (0.080)	2.54 (0.100)	2.54 (0.100)	3.30 (0.130)	2.54 (0.100)	2.54 (0.100)
(t) terminal min. max.	0.50 ± 0.25 (0.020 ± 0.010)	0.25 (0.010) 0.75 (0.030)	0.25 (0.010) 0.75 (0.030)	0.25 (0.010) 1.02 (0.040)	0.25 (0.010) 1.02 (0.040)	0.25 (0.010) 1.02 (0.040)	0.25 (0.010) 1.02 (0.040)	0.25 (0.010) 1.02 (0.040)	0.76 (0.030) 1.52 (0.060)

*Reflow Soldering Only



High Voltage MLC Chips



For 600V to 5000V Applications

C0G Dielectric Performance Characteristics

Capacitance Range	10 pF to 0.047 μ F (25°C, 1.0 \pm 0.2 Vrms at 1kHz, for \leq 1000 pF use 1 MHz)
Capacitance Tolerances	\pm 5%, \pm 10%, \pm 20%
Dissipation Factor	0.1% max. (\geq 25°C, 1.0 \pm 0.2 Vrms, 1kHz, for \leq 1000 pF use 1 MHz)
Operating Temperature Range	-55°C to +125°C
Temperature Characteristic	0 \pm 30 ppm/°C (0 VDC)
Voltage Ratings	600, 630, 1000, 1500, 2000, 2500, 3000, 4000 & 5000 VDC (+125°C)
Insulation Resistance (+25°C, at 500 VDC)	100K M Ω min. or 1000 M Ω - μ F min., whichever is less
Insulation Resistance (+125°C, at 500 VDC)	10K M Ω min. or 100 M Ω - μ F min., whichever is less
Dielectric Strength	Minimum 120% rated voltage for 5 seconds at 50 mA max. current

HIGH VOLTAGE C0G CAPACITANCE VALUES

VOLTAGE	0805	1206	1210	1808	1812	1825	2220	2225	3640	
600/630	min.	10pF	10 pF	100 pF	100 pF	100 pF	1000 pF	1000 pF	1000 pF	1000 pF
	max.	330pF	1200 pF	2700 pF	3300 pF	5600 pF	0.012 μ F	0.012 μ F	0.018 μ F	0.047 μ F
1000	min.	10pF	10 pF	10 pF	100 pF	100 pF	100 pF	1000 pF	1000 pF	1000 pF
	max.	180pF	560 pF	1500 pF	2200 pF	3300 pF	8200 pF	0.010 μ F	0.010 μ F	0.022 μ F
1500	min.	—	10 pF	10 pF	10 pF	10 pF	100 pF	100 pF	100 pF	100 pF
	max.	—	270 pF	330 pF	820 pF	1800 pF	4700 pF	4700 pF	5600 pF	0.010 μ F
2000	min.	—	10 pF	10 pF	10 pF	10 pF	100 pF	100 pF	100 pF	100 pF
	max.	—	120 pF	270 pF	330 pF	680 pF	1800 pF	2200 pF	2700 pF	6800 pF
2500	min.	—	—	—	10 pF	10 pF	100 pF	100 pF	100 pF	100 pF
	max.	—	—	—	180 pF	470 pF	1200 pF	1500 pF	1800 pF	3900 pF
3000	min.	—	—	—	10 pF	10 pF	10 pF	10 pF	10 pF	100 pF
	max.	—	—	—	120 pF	330 pF	820 pF	1000 pF	1200 pF	2700 pF
4000	min.	—	—	—	10 pF	10 pF	10 pF	10 pF	10 pF	100 pF
	max.	—	—	—	47 pF	150 pF	330 pF	470 pF	560 pF	1200 pF
5000	min.	—	—	—	—	—	—	—	—	10 pF
	max.	—	—	—	—	—	—	—	—	820 pF

X7R Dielectric Performance Characteristics

Capacitance Range	10 pF to 0.56 μ F (25°C, 1.0 \pm 0.2 Vrms at 1kHz)
Capacitance Tolerances	\pm 10%; \pm 20%; +80%, -20%
Dissipation Factor	2.5% max. (\geq 25°C, 1.0 \pm 0.2 Vrms, 1kHz)
Operating Temperature Range	-55°C to +125°C
Temperature Characteristic	\pm 15% (0 VDC)
Voltage Ratings	600, 630, 1000, 1500, 2000, 2500, 3000, 4000 & 5000 VDC (+125°C)
Insulation Resistance (+25°C, at 500 VDC)	100K M Ω min. or 1000 M Ω - μ F min., whichever is less
Insulation Resistance (+125°C, at 500 VDC)	10K M Ω min. or 100 M Ω - μ F min., whichever is less
Dielectric Strength	Minimum 120% rated voltage for 5 seconds at 50 mA max. current

HIGH VOLTAGE X7R MAXIMUM CAPACITANCE VALUES

VOLTAGE	0805	1206	1210	1808	1812	1825	2220	2225	3640	
600/630	min.	100pF	100 pF	1000 pF	1000 pF	1000 pF	0.010 μ F	0.010 μ F	0.010 μ F	0.010 μ F
	max.	6800pF	0.022 μ F	0.056 μ F	0.068 μ F	0.120 μ F	0.270 μ F	0.270 μ F	0.330 μ F	0.560 μ F
1000	min.	100pF	100 pF	1000 pF	1000 pF	1000 pF	1000 pF	1000 pF	1000 pF	0.010 μ F
	max.	1500pF	6800 pF	0.015 μ F	0.018 μ F	0.039 μ F	0.100 μ F	0.120 μ F	0.150 μ F	0.220 μ F
1500	min.	—	100 pF	100 pF	100 pF	100 pF	1000 pF	1000 pF	1000 pF	1000 pF
	max.	—	2700 pF	6800 pF	6800 pF	0.015 μ F	0.056 μ F	0.056 μ F	0.068 μ F	0.100 μ F
2000	min.	—	10 pF	100 pF	100 pF	100 pF	1000 pF	1000 pF	1000 pF	1000 pF
	max.	—	1500 pF	3900 pF	3300 pF	8200 pF	0.027 μ F	0.027 μ F	0.033 μ F	0.027 μ F
2500	min.	—	—	—	10 pF	10 pF	100 pF	100 pF	100 pF	1000 pF
	max.	—	—	—	2200 pF	5600 pF	0.015 μ F	0.018 μ F	0.022 μ F	0.022 μ F
3000	min.	—	—	—	10 pF	10 pF	100 pF	100 pF	100 pF	1000 pF
	max.	—	—	—	1800 pF	4700 pF	0.012 μ F	0.012 μ F	0.015 μ F	0.018 μ F
4000	min.	—	—	—	—	—	—	—	—	100 pF
	max.	—	—	—	—	—	—	—	—	6800 pF
5000	min.	—	—	—	—	—	—	—	—	100 pF
	max.	—	—	—	—	—	—	—	—	3300 pF

High Voltage MLC Chips Tin/Lead Termination "B"



For 600V to 5000V Application

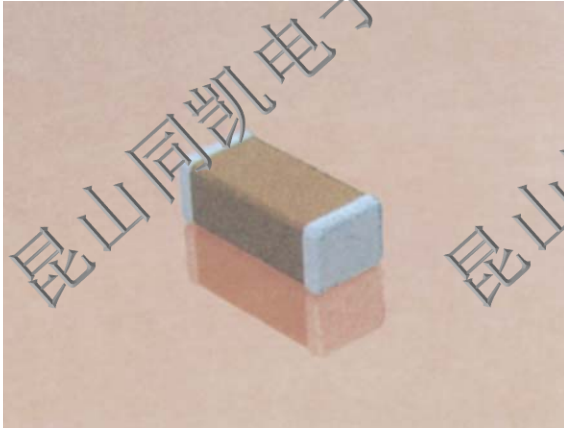

AVX Corporation will support those customers for commercial and military Multilayer Ceramic Capacitors with a termination consisting of 5% minimum lead. This termination is indicated by the use of a "B" in the 12th position of the AVX Catalog Part Number. This fulfills AVX's commitment to providing a full range of products to our customers. AVX has provided in the following pages, a full range of values that we are offering in this "B" termination.

Larger physical sizes than normally encountered chips are used to make high voltage MLC chip product. Special precautions must be taken in applying these chips in surface mount assemblies. The temperature gradient during heating or cooling cycles should not exceed 4°C per second. The preheat temperature must be within 50°C of the peak temperature reached by the ceramic bodies through the soldering process. Chip sizes 1210 and larger should be reflow soldered only. Capacitors may require protective surface coating to prevent external arcing.

NEW 630V RANGE

HOW TO ORDER

LD08	A	A	271	K	A	B	1	A
AVX Style	Voltage	Temperature Coefficient	Capacitance Code (2 significant digits + no. of zeros)	Capacitance Tolerance	Test Level	Termination	Packaging	Special Code
LD05 - 0805	600V/630V = G	COG = A	Examples: 10 pF = 100	COG: J = ±5%	A = Standard	B = 5% Min Pb	1 = 7" Reel	A = Standard
LD06 - 1206	1000V = A	X7R = C	100 pF = 101	K = ±10%			3 = 13" Reel	
LD10 - 1210	1500V = S		1,000 pF = 102	M = ±20%			9 = Bulk	
LD08 - 1808	2000V = G		22,000 pF = 223	X7R: K = ±10%				
LD12 - 1812	2500V = W		220,000 pF = 224	M = ±20%				
LD13 - 1825	3000V = H		1 μF = 105	Z = +80%, -20%				
LD20 - 2220	4000V = J							
LD14 - 2225	5000V = K							
LD40 - 3640								

Notes: Capacitors with X7R dielectrics are not intended for applications across AC supply mains or AC line filtering with polarity reversal. Contact plant for recommendations. Contact factory for availability of Termination and Tolerance options for Specific Part Numbers.

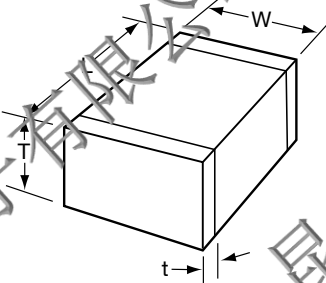

DIMENSIONS

millimeters (inches)

SIZE	LD05 (0805)	LD06 (1206)	LD10* (1210)	LD08* (1808)	LD12* (1812)	LD13* (1825)	LD20* (2220)	LD25* (2325)	LD40* (3640)
(L) Length	2.01 ± 0.20 (0.079 ± 0.008)	3.20 ± 0.20 (0.126 ± 0.008)	3.20 ± 0.20 (0.126 ± 0.008)	4.57 ± 0.25 (0.180 ± 0.010)	4.50 ± 0.30 (0.177 ± 0.012)	4.50 ± 0.30 (0.177 ± 0.012)	5.70 ± 0.40 (0.224 ± 0.016)	5.73 ± 0.25 (0.225 ± 0.010)	9.14 ± 0.25 (0.360 ± 0.010)
(W) Width	1.25 ± 0.20 (0.049 ± 0.008)	1.60 ± 0.20 (0.063 ± 0.008)	2.50 ± 0.20 (0.098 ± 0.008)	2.03 ± 0.25 (0.080 ± 0.010)	3.20 ± 0.20 (0.126 ± 0.008)	6.40 ± 0.30 (0.252 ± 0.012)	5.00 ± 0.40 (0.197 ± 0.016)	6.35 ± 0.25 (0.250 ± 0.010)	10.2 ± 0.25 (0.400 ± 0.010)
(T) Thickness Max.	1.30 (0.051)	1.52 (0.060)	1.70 (0.067)	2.03 (0.080)	2.54 (0.100)	2.54 (0.100)	3.30 (0.130)	2.54 (0.100)	2.54 (0.100)
(t) terminal min. max.	0.50 ± 0.25 (0.020 ± 0.010)	0.25 (0.010) 0.75 (0.030)	0.25 (0.010) 0.75 (0.030)	0.25 (0.010) 1.02 (0.040)	0.25 (0.010) 1.02 (0.040)	0.25 (0.010) 1.02 (0.040)	0.25 (0.010) 1.02 (0.040)	0.25 (0.010) 1.02 (0.040)	0.76 (0.030) 1.52 (0.060)

* Reflow soldering only.



High Voltage MLC Chips Tin/Lead Termination "B"



For 600V to 5000V Application

C0G Dielectric Performance Characteristics

Capacitance Range	10 pF to 0.047 μ F (25°C, 1.0 \pm 0.2 Vrms at 1kHz, for \leq 1000 pF use 1 MHz)
Capacitance Tolerances	\pm 5%, \pm 10%, \pm 20%
Dissipation Factor	0.1% max. (+25°C, 1.0 \pm 0.2 Vrms, 1kHz, for \leq 1000 pF use 1 MHz)
Operating Temperature Range	-55°C to +125°C
Temperature Characteristic	0 \pm 30 ppm/°C (0 VDC)
Voltage Ratings	600, 630, 1000, 1500, 2000, 2500, 3000, 4000 & 5000 VDC (+125°C)
Insulation Resistance (+25°C, at 500 VDC)	100K M Ω min. or 1000 M Ω - μ F min., whichever is less
Insulation Resistance (+125°C, at 500 VDC)	10K M Ω min. or 100 M Ω - μ F min., whichever is less
Dielectric Strength	Minimum 120% rated voltage for 5 seconds at 50 mA max. current

HIGH VOLTAGE C0G CAPACITANCE VALUES

VOLTAGE	LD05 (0805)	LD06 (1206)	LD10 (1210)	LD08 (1808)	LD12 (1812)	LD25 (1825)	LD20 (2220)	LD25 (2225)	LD40 (3640)
600/630	min.	10pF	10 pF	100 pF	100 pF	100 pF	1000 pF	1000 pF	1000 pF
	max.	330pF	1200 pF	2700 pF	3300 pF	5600 pF	0.012 μ F	0.012 μ F	0.018 μ F
1000	min.	10pF	10 pF	10 pF	100 pF	100 pF	1000 pF	1000 pF	1000 pF
	max.	180pF	560 pF	1500 pF	2200 pF	3300 pF	8300 pF	0.010 μ F	0.010 μ F
1500	min.	—	10 pF	10 pF	10 pF	10 pF	100 pF	100 pF	100 pF
	max.	—	270 pF	680 pF	820 pF	1800 pF	4700 pF	4700 pF	5600 pF
2000	min.	—	10 pF	10 pF	10 pF	10 pF	100 pF	100 pF	100 pF
	max.	—	120 pF	270 pF	330 pF	680 pF	1800 pF	2200 pF	2700 pF
2500	min.	—	—	—	10 pF	10 pF	10 pF	100 pF	100 pF
	max.	—	—	—	180 pF	470 pF	1200 pF	1500 pF	1800 pF
3000	min.	—	—	—	10 pF	10 pF	10 pF	10 pF	10 pF
	max.	—	—	—	120 pF	330 pF	820 pF	1000 pF	1200 pF
4000	min.	—	—	—	10 pF	10 pF	10 pF	10 pF	10 pF
	max.	—	—	—	47 pF	150 pF	330 pF	470 pF	560 pF
5000	min.	—	—	—	—	—	—	—	10 pF
	max.	—	—	—	—	—	—	—	820 pF

X7R Dielectric Performance Characteristics

Capacitance Range	10 pF to 0.56 μ F (25°C, 1.0 \pm 0.2 Vrms at 1kHz)
Capacitance Tolerances	\pm 10%; \pm 20%; +80%, -20%
Dissipation Factor	2.5% max. (+25°C, 1.0 \pm 0.2 Vrms, 1kHz)
Operating Temperature Range	-55°C to +125°C
Temperature Characteristic	\pm 15% (0 VDC)
Voltage Ratings	600, 630, 1000, 1500, 2000, 2500, 3000, 4000 & 5000 VDC (+125°C)
Insulation Resistance (+25°C, at 500 VDC)	100K M Ω min. or 1000 M Ω - μ F min., whichever is less
Insulation Resistance (+125°C, at 500 VDC)	10K M Ω min. or 100 M Ω - μ F min., whichever is less
Dielectric Strength	Minimum 120% rated voltage for 5 seconds at 50 mA max. current

HIGH VOLTAGE X7R MAXIMUM CAPACITANCE VALUES

VOLTAGE	LD05 (0805)	LD06 (1206)	LD10 (1210)	LD08 (1808)	LD12 (1812)	LD25 (1825)	LD20 (2220)	LD25 (2225)	LD40 (3640)
600/630	min.	100pF	1000 pF	1000 pF	1000 pF	1000 pF	0.010 μ F	0.010 μ F	0.010 μ F
	max.	6800pF	0.022 μ F	0.056 μ F	0.068 μ F	0.120 μ F	0.270 μ F	0.270 μ F	0.330 μ F
1000	min.	100pF	100 pF	1000 pF	1000 pF	1000 pF	1000 pF	1000 pF	1000 pF
	max.	1500pF	6800 pF	0.015 μ F	0.018 μ F	0.039 μ F	0.100 μ F	0.120 μ F	0.150 μ F
1500	min.	—	100 pF	100 pF	100 pF	100 pF	1000 pF	1000 pF	1000 pF
	max.	—	2700 pF	6800 pF	6800 pF	0.015 μ F	0.056 μ F	0.056 μ F	0.068 μ F
2000	min.	—	10 pF	100 pF	100 pF	100 pF	1000 pF	1000 pF	1000 pF
	max.	—	1500 pF	3900 pF	3300 pF	8200 pF	0.027 μ F	0.027 μ F	0.033 μ F
2500	min.	—	—	—	10 pF	10 pF	100 pF	100 pF	1000 pF
	max.	—	—	—	2200 pF	5600 pF	0.015 μ F	0.015 μ F	0.022 μ F
3000	min.	—	—	—	10 pF	10 pF	100 pF	100 pF	1000 pF
	max.	—	—	—	1800 pF	4700 pF	0.012 μ F	0.012 μ F	0.015 μ F
4000	min.	—	—	—	—	—	—	—	100 pF
	max.	—	—	—	—	—	—	—	6800 pF
5000	min.	—	—	—	—	—	—	—	100 pF
	max.	—	—	—	—	—	—	—	3300 pF

CECC Ceramic Chips



FEATURES

High Reliability CECC Ceramic Chips Capacitors for Military & Avionics applications

HOW TO ORDER

AN	13	Z	E	0104	J	T3
AVX Style	Size	Class	Voltage	Capacitance	Tolerance	Packaging
AN = Nickel Barrier → SnPb finish AC = Silver Palladium	12 = 0805 20 = 1206 13 = 1210 14 = 1812 15 = 2220	C = NP0 Z = X7R	D = 50/63 E = 100 F = 200	EIA code on 3 or 4 digits	NPO F = ±1% G = ±2% J = ±5% K = ±10% X7R J = ±5% K = ±10% M = ±20%	SUFFIX Burn-in 100% 168H = T5 Burn-in 100% 48H = T3 No burn-in = --

QUALIFIED VS CECC 32101-801

Class: NP0 + X7R (2C1/BX available on request)
 Sizes: 0805, 1206, 1210, 1812, 2220 (0603 qualification pending)
 Voltages: 50, 100, 200 (500V on request)
 Terminations: Silver Palladium or Nickel barrier + tin lead finish

CAPACITANCE vs VOLTAGE TABLE

Size	NP0*			X7R**		
	50V	100V	200V	50V	100V	200V
0805	4.7 → 1500pF	4.7 → 1500pF	10 → 470pF	0.47 → 68nF	0.47 → 39nF	0.33 → 18nF
1206	10 → 4700pF	10 → 4700pF	10 → 1500pF	1 → 180nF	1 → 100nF	0.1 → 39nF
1210	10 → 8200pF	10 → 8200pF	22 → 2700pF	10 → 330nF	4.7 → 220nF	0.47 → 100nF
1812	0.1 → 18nF	0.1 → 18nF	0.47 → 5.6nF	47 → 680nF	10 → 470nF	1 → 180nF
2220	0.47 → 39nF	0.47 → 39nF	0.1 → 12nF	0.1 → 1.5µF	0.047 → 1µF	4.7 → 390nF

* NP0 Class (range available with tolerance: 1, 2, 5, 10%)

** X7R Class (range available with tolerance: 5, 10, 20%)

Available Reliability Levels:

- Suffix: -- = qualified following CECC 32101-801 [no burn-in]
- Suffix: T3 = according to CECC 32100-002 or 003; Established reliability level (Equivalent to MIL-R) [100% burn-in: 48H @ 2 x Ur]
- Suffix: T5 = according to CECC 32100-002 or 003; Established reliability level (Equivalent to MIL-S) [100% burn-in: 168H @ 2 x Ur]

MIL-PRF-55681/Chips

Part Number Example
CDR01 thru CDR06

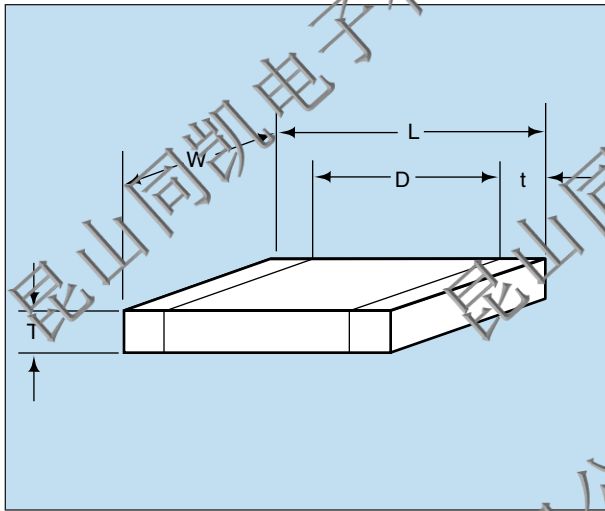

MILITARY DESIGNATION PER MIL-PRF-55681

Part Number Example

CDR01 BP 101 B K S M

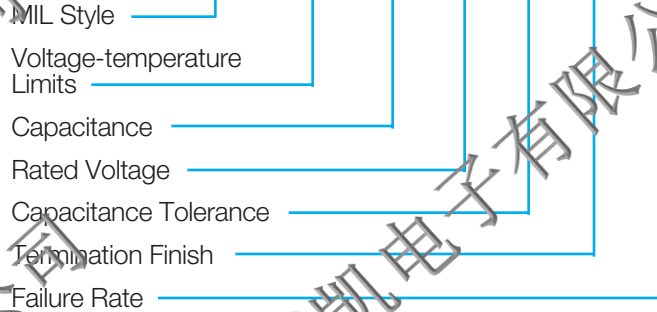

NOTE: Contact factory for availability of Termination and Tolerance Options for Specific Part Numbers.

MIL Style: CDR01, CDR02, CDR03, CDR04, CDR05, CDR06

Voltage Temperature Limits:

BP = 0 ± 30 ppm/°C without voltage; 0 ± 30 ppm/°C with rated voltage from -55°C to +125°C

BX = $\pm 15\%$ without voltage; +15 -25% with rated voltage from -55°C to +125°C

Capacitance: Two digit figures followed by multiplier (number of zeros to be added) e.g., 101 = 100 pF

Rated Voltage: A = 50V, B = 100V

Capacitance Tolerance: J $\pm 5\%$, K $\pm 10\%$, M $\pm 20\%$

Termination Finish:

M = Palladium Silver
N = Silver Nickel Gold
S = Solder-coated

U = Base Metallization/Barrier Metal/Solder Coated*
W = Base Metallization/Barrier Metal/Tinned (Tin or Tin/Lead Alloy)

*Solder shall have a melting point of 200°C or less.

Failure Rate Level: M = 1.0%, P = .1%, R = .01%, S = .001%

Packaging: Bulk is standard packaging. Tape and reel per RS481 is available upon request.

CROSS REFERENCE: AVX/MIL-PRF-55681/CDR01 THRU CDR06*

Per MIL-PRF-55681	AVX Style	Length (L)	Width (W)	Thickness (T)		Termination Band (t)			
				Max.	Min.	Max.	Min.		
CDR01	0805	.080 \pm .015	.050 \pm .015	.055	.020	—	.030	—	.010
CDR02	1805	.180 \pm .015	.050 \pm .015	.055	.020	—	—	.030	.010
CDR03	1808	.180 \pm .015	.080 \pm .018	.080	.020	—	—	.030	.010
CDR04	1812	.180 \pm .015	.125 \pm .015	.080	.020	—	—	.030	.010
CDR05	1825	.180 \pm .020 -.015	.250 \pm .020 -.015	.080	.020	—	—	.030	.010
CDR06	2225	.225 \pm .020	.250 \pm .020	.080	.020	—	—	.030	.010

*For CDR11, 12, 13, and 14 see AVX Microwave Chip Capacitor Catalog



MIL-PRF-55681/Chips

Military Part Number Identification

CDR01 thru CDR06



CDR01 thru CDR06 to MIL-PRF-55681

Military Type Designation	Capacitance in nF	Capacitance tolerance	Rated temperature and voltage-temperature limits	VWDC	Military Type Designation	Capacitance in pF	Capacitance tolerance	Rated temperature and voltage-temperature limits	VWDC
AVX Style 0905/CDR01					AVX Style 1808/CDR03				
CDR01BP100B---	10	J,K	BP	100	CDR03BP331B---	330	J,K	BP	100
CDR01BP120B---	12	J	BP	100	CDR03BP391B---	390	J	BP	100
CDR01BP150B---	15	J,K	BP	100	CDR03BP471B---	470	J,K	BP	100
CDR01BP180B---	18	J	BP	100	CDR03BP561B---	560	J	BP	100
CDR01BP220B---	22	J,K	BP	100	CDR03BP681B---	680	J,K	BP	100
CDR01BP270B---	27	J	BP	100	CDR03BP821B---	820	J	BP	100
CDR01BP330B---	33	J,K	BP	100	CDR03BP102B---	1000	J,K	BP	100
CDR01BP390B---	39	J	BP	100	CDR03BX123B---	12,000	K	BX	100
CDR01BP470B---	47	J,K	BP	100	CDR03BX153B---	15,000	K,M	BX	100
CDR01BP560B---	56	J	BP	100	CDR03BX183B---	18,000	K	BX	100
CDR01BP680B---	68	J,K	BP	100	CDR03BX223B---	22,000	K,M	BX	100
CDR01BP820B---	82	J	BP	100	CDR03BX273B---	27,000	K	BX	100
CDR01BP101B---	100	J,K	BP	100	CDR03BX333B---	33,000	K,M	BX	100
CDR01B--121B---	120	J,K	BP, BX	700	CDR03BX393A---	39,000	K	BX	50
CDR01B--151B---	150	J,K	BP, BX	100	CDR03BX473A---	47,000	K,M	BX	50
CDR01B--181B---	180	J,K	BP, BX	100	CDR03BX563A---	56,000	K	BX	50
CDR01BX221B---	220	K,M	BX	100	CDR03BX683A---	68,000	K,M	BX	50
CDR01BX271B---	270	K	BX	100	AVX Style 1812/CDR04				
CDR01BX331B---	330	K,M	BX	100	CDR04BP122B---	1200	J	BP	100
CDR01BX391B---	390	K	BX	100	CDR04BP152B---	1500	J,K	BP	100
CDR01BX471B---	470	K,M	BX	100	CDR04BP182B---	1800	J	BP	100
CDR01BX561B---	560	K	BX	100	CDR04BP222B---	2200	J,K	BP	100
CDR01BX681B---	680	K,M	BX	100	CDR04BP272B---	2700	J	BP	100
CDR01BX821B---	820	K	BX	100	CDR04BP332B---	3300	J,K	BP	100
CDR01BX102B---	1000	K,M	BX	100	CDR04BX393B---	39,000	K	BX	100
CDR01BX122B---	1200	K	BX	100	CDR04BX473B---	47,000	K,M	BX	100
CDR01BX152B---	1500	K,M	BX	100	CDR04BX563B---	56,000	K	BX	100
CDR01BX182B---	1800	K	BX	100	CDR04BX823A---	82,000	K	BX	50
CDR01BX222B---	2200	K,M	BX	100	CDR04BX104A---	100,000	K,M	BX	50
CDR01BX272B---	2700	K	BX	100	CDR04BX124A---	120,000	K	BX	50
CDR01BX332B---	3300	K,M	BX	100	CDR04BX154A---	150,000	K,M	BX	50
CDR01BX392A---	3900	K	BX	50	CDR04BX184A---	180,000	K	BX	50
CDR01BX472A---	4700	K,M	BX	50	AVX Style 1825/CDR05				
AVX Style 1805/CDR02					CDR05BP392B---	3900	J,K	BP	100
CDR02BP221B---	220	J,K	BP	100	CDR05BP472B---	4700	J,K	BP	100
CDR02BP271B---	270	J	BP	100	CDR05BP562B---	5600	J,K	BP	100
CDR02BX392B---	3900	K	BX	100	CDR05BX683B---	68,000	K,M	BX	100
CDR02BX472B---	4700	K,M	BX	100	CDR05BX823B---	82,000	K	BX	100
CDR02BX562B---	5600	K	BX	100	CDR05BX104B---	100,000	K,M	BX	100
CDR02BX682B---	6800	K,M	BX	100	CDR05BX124B---	120,000	K	BX	100
CDR02BX822B---	8200	K	BX	100	CDR05BX154B---	150,000	K,M	BX	100
CDR02BX103B---	10,000	K,M	BX	100	CDR05BX224A---	220,000	K,M	BX	50
CDR02BX123A---	12,000	K	BX	50	CDR05BX274A---	270,000	K	BX	50
CDR02BX153A---	15,000	K,M	BX	50	CDR05BX334A---	330,000	K,M	BX	50
CDR02BX183A---	18,000	K	BX	50	AVX Style 2225/CDR06				
CDR02BX223A---	22,000	K,M	BX	50	CDR06BP682B---	6800	J,K	BP	100
<ul style="list-style-type: none"> └─ Add appropriate failure rate └─ Add appropriate termination finish └─ Capacitance Tolerance 					CDR06BP822B---	8200	J,K	BP	100
					CDR06BP103B---	10,000	J,K	BP	100
					CDR06BX394A---	390,000	K	BX	50
					CDR06BX474A---	470,000	K,M	BX	50
<ul style="list-style-type: none"> └─ Add appropriate failure rate └─ Add appropriate termination finish └─ Capacitance Tolerance 									

MIL-PRF-55681/Chips

Part Number Example
CDR31 thru CDR35

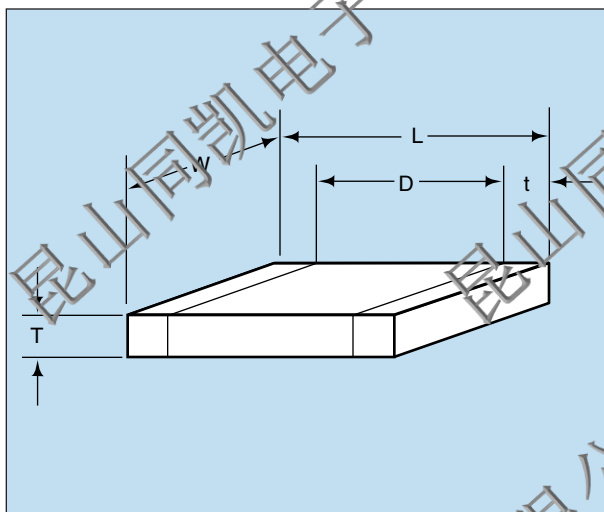

MILITARY DESIGNATION PER MIL-PRF-55681

Part Number Example

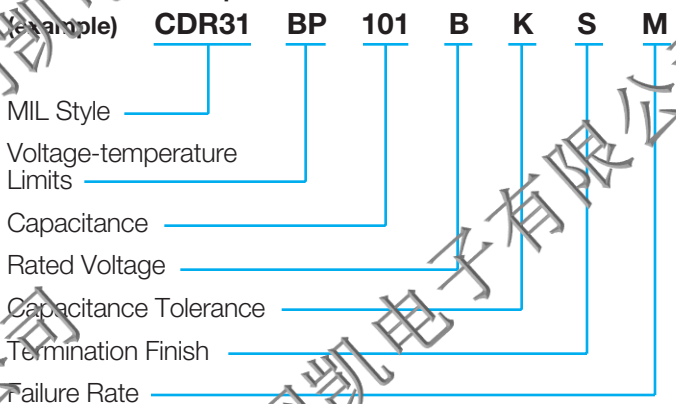

NOTE: Contact factory for availability of Termination and Tolerance Options for Specific Part Numbers.

MIL Style: CDR31, CDR32, CDR33, CDR34, CDR35

Voltage Temperature Limits:

BP = 0 ± 30 ppm/°C without voltage; 0 ± 30 ppm/°C with rated voltage from -55°C to +125°C

BX = $\pm 15\%$ without voltage; +15 -25% with rated voltage from -55°C to +125°C

Capacitance: Two digit figures followed by multiplier (number of zeros to be added) e.g., 101 = 100 pF

Rated Voltage: A = 50V, B = 100V

Capacitance Tolerance: C $\pm .25$ pF, D $\pm .5$ pF, F $\pm 1\%$
J $\pm 5\%$, K $\pm 10\%$, M $\pm 20\%$

Termination Finish:

M = Palladium Silver
N = Silver Nickel Gold
S = Solder-coated
Y = 100% Tin

U = Base Metallization/Barrier Metal/Solder Coated*
W = Base Metallization/Barrier Metal/Tinned (Tin or Tin/Lead Alloy)

*Solder shall have a melting point of 200°C or less.

Failure Rate Level: M = 1.0%, P = .1%, R = .01%
S = .001%

Packaging: Bulk is standard packaging. Tape and reel per RS481 is available upon request.

CROSS REFERENCE: AVX/MIL-PRF-55681/CDR31 THRU CDR35

Per MIL-PRF-55681 (Metric Sizes)	AVX Style	Length (L) (mm)	Width (W) (mm)	Thickness (T)		Termination Band (t)	
				Max. (mm)	Min. (mm)	Max. (mm)	Min. (mm)
CDR31	0805	2.00	1.25	1.3	.50	.70	.30
CDR32	1206	3.20	1.60	1.5	—	.70	.30
CDR33	1210	3.20	2.50	1.5	—	.70	.30
CDR34	1812	4.50	3.20	1.5	—	.70	.30
CDR35	1825	4.50	6.40	1.5	—	.70	.30

MIL-PRF-55681/Chips



Military Part Number Identification CDR31

CDR31 to MIL-PRF-55681/7

Military Type Designation 1/	Capacitance in pF	Capacitance tolerance	Rated temperature and voltage-temperature limits	WVDC	Military Type Designation 1/	Capacitance in pF	Capacitance tolerance	Rated temperature and voltage-temperature limits	WVDC
AVX Style 0805/CDR31 (BP)					AVX Style 0805/CDR31 (BP) cont'd				
CDR31BP1R0B---	1.0	B,C	BP	100	CDR31BP101B---	100	F,J,K	BP	100
CDR31BP1R1B---	1.1	B,C	BP	100	CDR31BP111B---	110	F,J,K	BP	100
CDR31BP1R2B---	1.2	B,C	BP	100	CDR31BP121B---	120	F,J,K	BP	100
CDR31BP1R3B---	1.3	B,C	BP	100	CDR31BP131B---	130	F,J,K	BP	100
CDR31BP1R5B---	1.5	B,C	BP	100	CDR31BP151B---	150	F,J,K	BP	100
CDR31BP1R6B---	1.6	B,C	BP	100	CDR31BP161B---	160	F,J,K	BP	100
CDR31BP1R8B---	1.8	B,C	BP	100	CDR31BP181B---	180	F,J,K	BP	100
CDR31BP2R0B---	2.0	B,C	BP	100	CDR31BP201B---	200	F,J,K	BP	100
CDR31BP2R2B---	2.2	B,C	BP	100	CDR31BP221B---	220	F,J,K	BP	100
CDR31BP2R4B---	2.4	B,C	BP	100	CDR31BP241B---	240	F,J,K	BP	100
CDR31BP2R7B---	2.7	B,C,D	BP	100	CDR31BP271B---	270	F,J,K	BP	100
CDR31BP3R0B---	3.0	B,C,D	BP	100	CDR31BP301B---	300	F,J,K	BP	100
CDR31BP3R3B---	3.3	B,C,D	BP	100	CDR31BP331B---	330	F,J,K	BP	100
CDR31BP3R6B---	3.6	B,C,D	BP	100	CDR31BP361B---	360	F,J,K	BP	100
CDR31BP3R9B---	3.9	B,C,D	BP	100	CDR31BP391B---	390	F,J,K	BP	100
CDR31BP4R3B---	4.3	B,C,D	BP	100	CDR31BP431B---	430	F,J,K	BP	100
CDR31BP4R7B---	4.7	B,C,D	BP	100	CDR31BP471B---	470	F,J,K	BP	100
CDR31BP5R1B---	5.1	B,C,D	BP	100	CDR31BP511A---	510	F,J,K	BP	50
CDR31BP5R6B---	5.6	B,C,D	BP	100	CDR31BP561A---	560	F,J,K	BP	50
CDR31BP6R2B---	6.2	B,C,D	BP	100	CDR31BP621A---	620	F,J,K	BP	50
CDR31BP6R8B---	6.8	B,C,D	BP	100	CDR31BP681A---	680	F,J,K	BP	50
CDR31BP7R5B---	7.5	B,C,D	BP	100	AVX Style 0805/CDR31 (BX)				
CDR31BP8R2B---	8.2	B,C,D	BP	100	CDR31BX471B---	470	K,M	BX	100
CDR31BP9R1B---	9.1	B,C,D	BP	100	CDR31BX561B---	560	K,M	BX	100
CDR31BP100B---	10	F,J,K	BP	100	CDR31BX681B---	680	K,M	BX	100
CDR31BP110B---	11	F,J,K	BP	100	CDR31BX821B---	820	K,M	BX	100
CDR31BP120B---	12	F,J,K	BP	100	CDR31BX102B---	1,000	K,M	BX	100
CDR31BP130B---	13	F,J,K	BP	100	CDR31BX122B---	1,200	K,M	BX	100
CDR31BP150B---	15	F,J,K	BP	100	CDR31BX152B---	1,500	K,M	BX	100
CDR31BP160B---	16	F,J,K	BP	100	CDR31BX182B---	1,800	K,M	BX	100
CDR31BP180B---	18	F,J,K	BP	100	CDR31BX222B---	2,200	K,M	BX	100
CDR31BP200B---	20	F,J,K	BP	100	CDR31BX272B---	2,700	K,M	BX	100
CDR31BP220B---	22	F,J,K	BP	100	CDR31BX332B---	3,300	K,M	BX	100
CDR31BP240B---	24	F,J,K	BP	100	CDR31BX392B---	3,900	K,M	BX	100
CDR31BP270B---	27	F,J,K	BP	100	CDR31BX472B---	4,700	K,M	BX	100
CDR31BP300B---	30	F,J,K	BP	100	CDR31BX562A---	5,600	K,M	BX	50
CDR31BP330B---	33	F,J,K	BP	100	CDR31BX682A---	6,800	K,M	BX	50
CDR31BP360B---	36	F,J,K	BP	100	CDR31BX822A---	8,200	K,M	BX	50
CDR31BP390B---	39	F,J,K	BP	100	CDR31BX103A---	10,000	K,M	BX	50
CDR31BP430B---	43	F,J,K	BP	100	CDR31BX123A---	12,000	K,M	BX	50
CDR31BP470B---	47	F,J,K	BP	100	CDR31BX153A---	15,000	K,M	BX	50
CDR31BP510B---	51	F,J,K	BP	100	CDR31BX183A---	18,000	K,M	BX	50
CDR31BP560B---	56	F,J,K	BP	100					
CDR31BP620B---	62	F,J,K	BP	100					
CDR31BP680B---	68	F,J,K	BP	100					
CDR31BP750B---	75	F,J,K	BP	100					
CDR31BP820B---	82	F,J,K	BP	100					
CDR31BP910B---	91	F,J,K	BP	100					

1/ Add appropriate failure rate

1/ Add appropriate termination finish

1/ Capacitance Tolerance

1/ Add appropriate failure rate

1/ Add appropriate termination finish

1/ Capacitance Tolerance

1/ The complete part number will include additional symbols to indicate capacitance tolerance, termination and failure rate level.

MIL-PRF-55681/Chips



Military Part Number Identification CDR32

CDR32 to MIL-PRF-55681/8

Military Type Designation 1/	Capacitance in pF	Capacitance tolerance	Rated temperature and voltage-temperature limits	WVDC	Military Type Designation 1/	Capacitance in pF	Capacitance tolerance	Rated temperature and voltage-temperature limits	WVDC
AVX Style 1206/CDR32 (BP)					AVX Style 1206/CDR32 (BP) cont'd				
CDR32BP1R0B---	1.0	B,C	BP	100	CDR32BP101B---	100	F,J,K	BP	100
CDR32BP1R1B---	1.1	B,C	BP	100	CDR32BP111B---	110	F,J,K	BP	100
CDR32BP1R2B---	1.2	B,C	BP	100	CDR32BP121B---	120	F,J,K	BP	100
CDR32BP1R3B---	1.3	B,C	BP	100	CDR32BP131B---	130	F,J,K	BP	100
CDR32BP1R5B---	1.5	B,C	BP	100	CDR32BP151B---	150	F,J,K	BP	100
CDR32BP1R6B---	1.6	B,C	BP	100	CDR32BP161B---	160	F,J,K	BP	100
CDR32BP1R8B---	1.8	B,C	BP	100	CDR32BP181B---	180	F,J,K	BP	100
CDR32BP2R0B---	2.0	B,C	BP	100	CDR32BP201B---	200	F,J,K	BP	100
CDR32BP2R2B---	2.2	B,C	BP	100	CDR32BP221B---	220	F,J,K	BP	100
CDR32BP2R4B---	2.4	B,C	BP	100	CDR32BP241B---	240	F,J,K	BP	100
CDR32BP2R7B---	2.7	B,C,D	BP	100	CDR32BP271B---	270	F,J,K	BP	100
CDR32BP3R0B---	3.0	B,C,D	BP	100	CDR32BP301B---	300	F,J,K	BP	100
CDR32BP3R3B---	3.3	B,C,D	BP	100	CDR32BP331B---	330	F,J,K	BP	100
CDR32BP3R6B---	3.6	B,C,D	BP	100	CDR32BP361B---	360	F,J,K	BP	100
CDR32BP3R9B---	3.9	B,C,D	BP	100	CDR32BP391B---	390	F,J,K	BP	100
CDR32BP4R3B---	4.3	B,C,D	BP	100	CDR32BP431B---	430	F,J,K	BP	100
CDR32BP4R7B---	4.7	B,C,D	BP	100	CDR32BP471B---	470	F,J,K	BP	100
CDR32BP5R1B---	5.1	B,C,D	BP	100	CDR32BP511B---	510	F,J,K	BP	100
CDR32BP5R6B---	5.6	B,C,D	BP	100	CDR32BP561B---	560	F,J,K	BP	100
CDR32BP6R2B---	6.2	B,C,D	BP	100	CDR32BP621B---	620	F,J,K	BP	100
CDR32BP6R8B---	6.8	B,C,D	BP	100	CDR32BP681B---	680	F,J,K	BP	100
CDR32BP7R5B---	7.5	B,C,D	BP	100	CDR32BP751B---	750	F,J,K	BP	100
CDR32BP8R2B---	8.2	B,C,D	BP	100	CDR32BP821B---	820	F,J,K	BP	100
CDR32BP9R1B---	9.1	B,C,D	BP	100	CDR32BP911B---	910	F,J,K	BP	100
CDR32BP100B---	10	F,J,K	BP	100	CDR32BP102B---	1,000	F,J,K	BP	100
CDR32BP110B---	11	F,J,K	BP	100	CDR32BP112A---	1,100	F,J,K	BP	50
CDR32BP120B---	12	F,J,K	BP	100	CDR32BP122A---	1,200	F,J,K	BP	50
CDR32BP130B---	13	F,J,K	BP	100	CDR32BP132A---	1,300	F,J,K	BP	50
CDR32BP150B---	15	F,J,K	BP	100	CDR32BP152A---	1,500	F,J,K	BP	50
CDR32BP160B---	16	F,J,K	BP	100	CDR32BP162A---	1,600	F,J,K	BP	50
CDR32BP180B---	18	F,J,K	BP	100	CDR32BP182A---	1,800	F,J,K	BP	50
CDR32BP200B---	20	F,J,K	BP	100	CDR32BP202A---	2,000	F,J,K	BP	50
CDR32BP220B---	22	F,J,K	BP	100	CDR32BP222A---	2,200	F,J,K	BP	50
CDR32BP240B---	24	F,J,K	BP	100	AVX Style 1206/CDR32 (BX)				
CDR32BP270B---	27	F,J,K	BP	100	CDR32BX472B---	4,700	K,M	BX	100
CDR32BP300B---	30	F,J,K	BP	100	CDR32BX562B---	5,600	K,M	BX	100
CDR32BP330B---	33	F,J,K	BP	100	CDR32BX682B---	6,800	K,M	BX	100
CDR32BP360B---	36	F,J,K	BP	100	CDR32BX822B---	8,200	K,M	BX	100
CDR32BP390B---	39	F,J,K	BP	100	CDR32BX103B---	10,000	K,M	BX	100
CDR32BP430B---	43	F,J,K	BP	100	CDR32BX123B---	12,000	K,M	BX	100
CDR32BP470B---	47	F,J,K	BP	100	CDR32BX153B---	15,000	K,M	BX	100
CDR32BP510B---	51	F,J,K	BP	100	CDR32BX183A---	18,000	K,M	BX	50
CDR32BP560B---	56	F,J,K	BP	100	CDR32BX223A---	22,000	K,M	BX	50
CDR32BP620B---	62	F,J,K	BP	100	CDR32BX273A---	27,000	K,M	BX	50
CDR32BP680B---	68	F,J,K	BP	100	CDR32BX333A---	33,000	K,M	BX	50
CDR32BP750B---	75	F,J,K	BP	100	CDR32BX393A---	39,000	K,M	BX	50
CDR32BP820B---	82	F,J,K	BP	100					
CDR32BP910B---	91	F,J,K	BP	100					

Add appropriate failure rate
 Add appropriate termination finish
 Capacitance Tolerance

Add appropriate failure rate
 Add appropriate termination finish
 Capacitance Tolerance

1/ The complete part number will include additional symbols to indicate capacitance tolerance, termination and failure rate level.

MIL-PRF-55681/Chips



Military Part Number Identification CDR33/34/35

CDR33/34/35 to MIL-PRF-55681/9/10/11

Military Type Designation 1/	Capacitance in pF	Capacitance tolerance	Rated temperature and voltage-temperature limits	WVDC	Military Type Designation 1/	Capacitance in pF	Capacitance tolerance	Rated temperature and voltage-temperature limits	WVDC
AVX Style 1210/CDR33 (BP)					AVX Style 1812/CDR34 (BX)				
CDR33BP102B---	1,000	F,J,K	BP	100	CDR34BX273B---	27,000	K,M	BX	100
CDR33BP112B---	1,100	F,J,K	BP	100	CDR34BX333B---	33,000	K,M	BX	100
CDR33BP122B---	1,200	F,J,K	BP	100	CDR34BX393B---	39,000	K,M	BX	100
CDR33BP132B---	1,300	F,J,K	BP	100	CDR34BX473B---	47,000	K,M	BX	100
CDR33BP152B---	1,500	F,J,K	BP	100	CDR34BX563B---	56,000	K,M	BX	100
CDR33BP162B---	1,600	F,J,K	BP	100	CDR34BX104A---	100,000	K,M	BX	50
CDR33BP182B---	1,800	F,J,K	BP	100	CDR34BX124A---	120,000	K,M	BX	50
CDR33BP202B---	2,000	F,J,K	BP	100	CDR34BX154A---	150,000	K,M	BX	50
CDR33BP222B---	2,200	F,J,K	BP	100	CDR34BX184A---	180,000	K,M	BX	50
CDR33BP242A---	2,400	F,J,K	BP	50	AVX Style 1825/CDR35 (BP)				
CDR33BP272A---	2,700	F,J,K	BP	50	CDR35BP472B---	4,700	F,J,K	BP	100
CDR33BP302A---	3,000	F,J,K	BP	50	CDR35BP512B---	5,100	F,J,K	BP	100
CDR33BP332A---	3,300	F,J,K	BP	50	CDR35BP562B---	5,600	F,J,K	BP	100
AVX Style 1210/CDR33 (BX)					CDR35BP622B---	6,200	F,J,K	BP	100
CDR33BX153B---	15,000	K,M	BX	100	CDR35BP682B---	6,800	F,J,K	BP	100
CDR33BX183B---	18,000	K,M	BX	100	CDR35BP752B---	7,500	F,J,K	BP	100
CDR33BX223B---	22,000	K,M	BX	100	CDR35BP822B---	8,200	F,J,K	BP	100
CDR33BX273B---	27,000	K,M	BX	100	CDR35BP912B---	9,100	F,J,K	BP	100
CDR33BX393A---	39,000	K,M	BX	50	CDR35BP103B---	10,000	F,J,K	BP	100
CDR33BX473A---	47,000	K,M	BX	50	CDR35BP123A---	11,000	F,J,K	BP	50
CDR33BX563A---	56,000	K,M	BX	50	CDR35BP123A---	12,000	F,J,K	BP	50
CDR33BX683A---	68,000	K,M	BX	50	CDR35BP133A---	13,000	F,J,K	BP	50
CDR33BX823A---	82,000	K,M	BX	50	CDR35BP153A---	15,000	F,J,K	BP	50
CDR33BX104A---	100,000	K,M	BX	50	CDR35BP163A---	16,000	F,J,K	BP	50
AVX Style 1812/CDR34 (BP)					CDR35BP183A---	18,000	F,J,K	BP	50
CDR34BP222B---	2,200	F,J,K	BP	100	CDR35BP203A---	20,000	F,J,K	BP	50
CDR34BP242B---	2,400	F,J,K	BP	100	CDR35BP223A---	22,000	F,J,K	BP	50
CDR34BP272B---	2,700	F,J,K	BP	100	AVX Style 1825/CDR35 (BX)				
CDR34BP302B---	3,000	F,J,K	BP	100	CDR35BX563B---	56,000	K,M	BX	100
CDR34BP332B---	3,300	F,J,K	BP	100	CDR35BX683B---	68,000	K,M	BX	100
CDR34BP362B---	3,600	F,J,K	BP	100	CDR35BX823B---	82,000	K,M	BX	100
CDR34BP392B---	3,900	F,J,K	BP	100	CDR35BX104B---	100,000	K,M	BX	100
CDR34BP432B---	4,300	F,J,K	BP	100	CDR35BX124B---	120,000	K,M	BX	100
CDR34BP472B---	4,700	F,J,K	BP	100	CDR35BX154B---	150,000	K,M	BX	100
CDR34BP512A---	5,100	F,J,K	BP	50	CDR35BX184A---	180,000	K,M	BX	50
CDR34BP562A---	5,600	F,J,K	BP	50	CDR35BX224A---	220,000	K,M	BX	50
CDR34BP622A---	6,200	F,J,K	BP	50	CDR35BX274A---	270,000	K,M	BX	50
CDR34BP682A---	6,800	F,J,K	BP	50	CDR35BX334A---	330,000	K,M	BX	50
CDR34BP752A---	7,500	F,J,K	BP	50	CDR35BX394A---	390,000	K,M	BX	50
CDR34BP822A---	8,200	F,J,K	BP	50	CDR35BX474A---	470,000	K,M	BX	50
CDR34BP912A---	9,100	F,J,K	BP	50					
CDR34BP103A---	10,000	F,J,K	BP	50					

1/ Add appropriate failure rate

2/ Add appropriate termination finish

3/ Capacitance Tolerance

1/ Add appropriate failure rate

2/ Add appropriate termination finish

3/ Capacitance Tolerance

1/ The complete part number will include additional symbols to indicate capacitance tolerance, termination and failure rate level.

Packaging of Chip Components



Automatic Insertion Packaging

TAPE & REEL QUANTITIES

All tape and reel specifications are in compliance with RS481.

	8mm	12mm	
Paper or Embossed Carrier	0612, 0508, 0805, 1206, 1210		
Embossed Only		1808	1812, 1825 2220, 2225
Paper Only	0201, 0306, 0402, 0603		
Qty. per Reel/7" Reel	2,000, 3,000 or 4,000, 10,000, 15,000 Contact factory for exact quantity	3,000	500, 1,000 Contact factory for exact quantity
Qty. per Reel/13" Reel	5,000, 10,000, 50,000 Contact factory for exact quantity	10,000	4,000

REEL DIMENSIONS

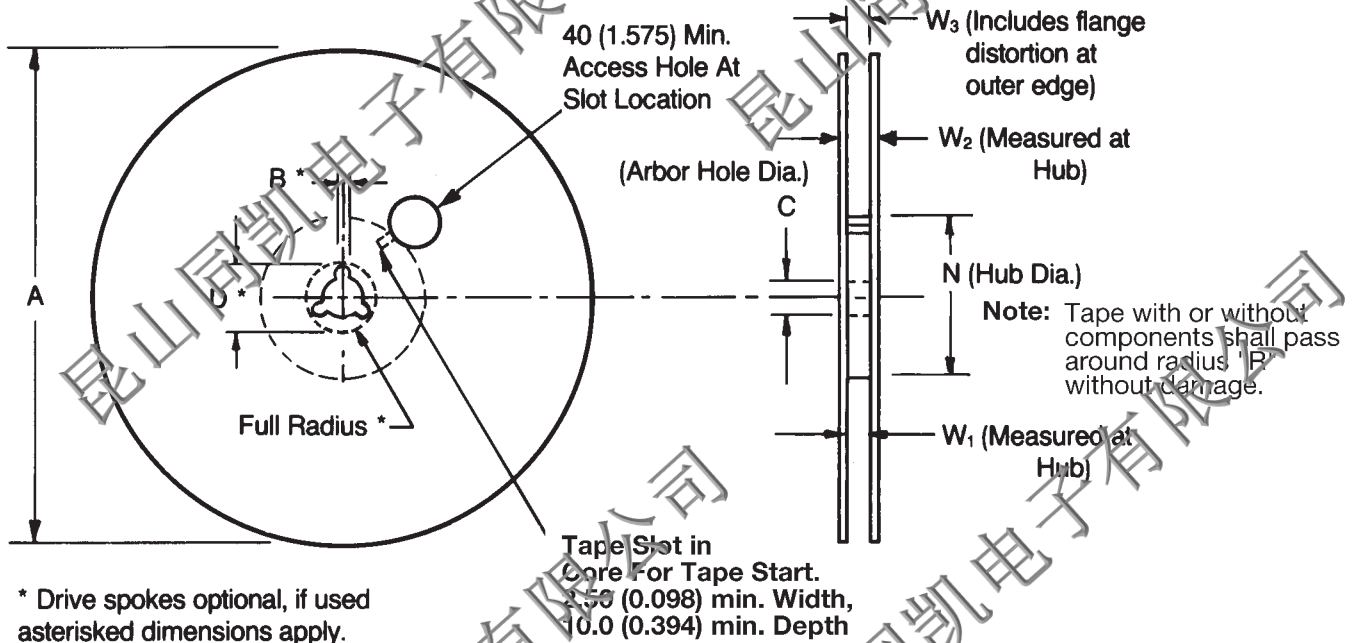

Tape Size ⁽¹⁾	A Max.	B* Min.	C	D* Min.	N Min.	W ₁	W ₂ Max.	W ₃
8mm						8.40 ^{+0.08} _(0.331^{+0.059})	14.4 (0.567)	7.90 Min. (0.311) 10.9 Max. (0.429)
12mm	330 (12.992)	4.5 (0.059)	13.0 ^{+0.50} _(0.512^{+0.020})	20.2 (0.795)	50.0 (1.969)	12.4 ^{+2.0} _(0.488^{+0.079})	18.4 (0.724)	11.9 Min. (0.469) 15.4 Max. (0.607)

Metric dimensions will govern.

English measurements rounded and for reference only.

(1) For tape sizes 16mm and 24mm (used with chip size 3640) consult EIA RS-481 latest revision.

Embossed Carrier Configuration



8 & 12mm Tape Only

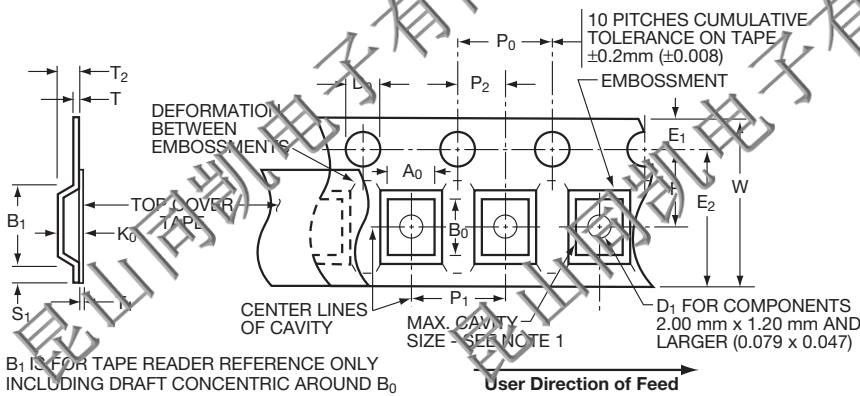

Chip Orientation

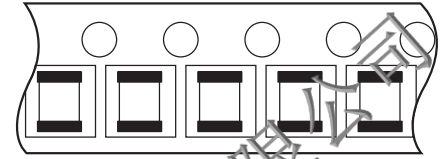

8 & 12mm Embossed Tape Metric Dimensions Will Govern

CONSTANT DIMENSIONS

Tape Size	D ₀	E	P ₀	P ₂	S ₁ Min.	T Max.	T ₁
8mm and 12mm	1.50 ^{+0.10} _{-0.00} (0.059 ^{+0.004} _{-0.000})	1.75 ± 0.10 (0.069 ± 0.004)	4.0 ± 0.10 (0.157 ± 0.004)	2.0 ± 0.05 (0.079 ± 0.002)	0.60 (0.024)	0.60 (0.024)	0.10 (0.004) Max.

VARIABLE DIMENSIONS

Tape Size	B ₁ Max.	D ₁ Min.	E ₂ Min.	F	P ₁ See Note 5	R Min. See Note 2	T ₂	W Max.	A ₀ B ₀ K ₀
8mm	4.35 (0.171)	1.00 (0.039)	6.25 (0.246)	3.50 ± 0.05 (0.138 ± 0.002)	4.00 ± 0.10 (0.157 ± 0.004)	25.0 (0.984)	2.50 Max. (0.098)	8.30 (0.327)	See Note 1
12mm	8.20 (0.323)	1.50 (0.059)	10.25 (0.404)	5.50 ± 0.05 (0.217 ± 0.002)	4.00 ± 0.10 (0.157 ± 0.004)	30.0 (1.181)	6.50 Max. (0.256)	12.3 (0.484)	See Note 1
8mm 1/2 Pitch	4.35 (0.171)	1.00 (0.039)	6.25 (0.246)	3.50 ± 0.05 (0.138 ± 0.002)	2.00 ± 0.10 (0.079 ± 0.004)	25.0 (0.984)	2.50 Max. (0.098)	8.30 (0.327)	See Note 1
12mm Double Pitch	8.20 (0.323)	1.50 (0.059)	10.25 (0.404)	5.50 ± 0.05 (0.217 ± 0.002)	8.00 ± 0.10 (0.315 ± 0.004)	30.0 (1.181)	6.50 Max. (0.256)	12.3 (0.484)	See Note 1

NOTES:

1. The cavity defined by A₀, B₀, and K₀ shall be configured to provide the following:

- Surround the component with sufficient clearance such that:
- the component does not protrude beyond the sealing plane of the cover tape.
 - the component can be removed from the cavity in the vertical direction without mechanical restriction, after the cover tape has been removed.
 - rotation of the component is limited to 20° maximum (see Sketches D & E).
 - lateral movement of the component is restricted to 0.5mm maximum (see Sketch F).

2. Tape with or without components shall pass around radius "R" without damage.

3. Bar code labeling (if required) shall be on the side of the reel opposite the round sprocket holes. Refer to EIA-556.

4. B₁ dimension is a reference dimension for tape feeder clearance only.

5. If P₁ = 2.5mm, the tape may not properly index in all tape feeders.

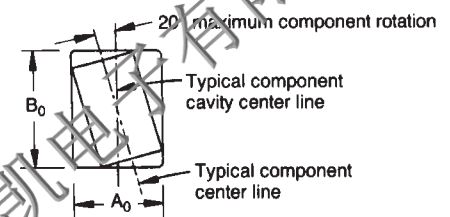
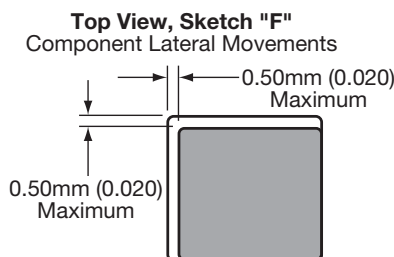
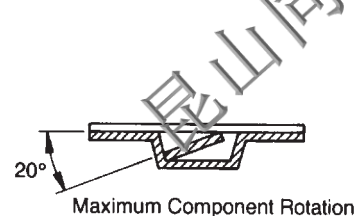

Paper Carrier Configuration



8 & 12mm Tape Only

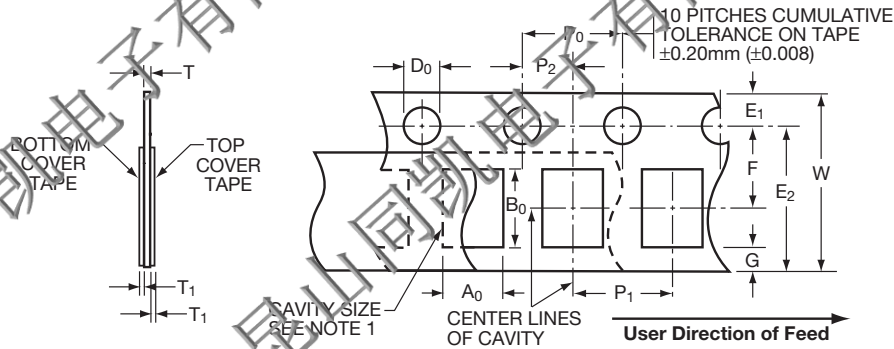

8 & 12mm Paper Tape Metric Dimensions Will Govern

CONSTANT DIMENSIONS

Tape Size	D ₀	E	P ₁	P ₂	T ₁	G. Min.	R Min.
8mm and 12mm	1.50 ^{+0.10} _(0.059^{-0.004})	1.75 ± 0.10 (0.069 ± 0.004)	4.00 ± 0.10 (0.157 ± 0.004)	2.00 ± 0.05 (0.079 ± 0.002)	0.10 (0.004) Max.	0.75 (0.030) Min.	25.0 (0.984) See Note 2 Min.

VARIABLE DIMENSIONS

Tape Size	P ₁ See Note 4	E ₂ Min.	F	W	A ₀ B ₀	T
8mm	4.00 ± 0.10 (0.157 ± 0.004)	6.25 (0.246)	3.50 ± 0.05 (0.138 ± 0.002)	8.00 ^{+0.30} _(0.315^{+0.012} -0.004)	See Note 1	1.10mm (0.043) Max. for Paper Base Tape and 1.60mm (0.063) Max. for Non-Paper Base Compositions
12mm	4.00 ± 0.010 (0.157 ± 0.004)	10.25 (0.404)	5.50 ± 0.05 (0.217 ± 0.002)	12.0 ± 0.30 (0.472 ± 0.012)		
8mm 1/2 Pitch	2.00 ± 0.05 (0.079 ± 0.002)	6.25 (0.246)	3.50 ± 0.05 (0.138 ± 0.002)	8.00 ^{+0.30} _(0.315^{+0.012} -0.004)		
12mm Double Pitch	8.00 ± 0.10 (0.315 ± 0.004)	10.25 (0.404)	5.50 ± 0.05 (0.217 ± 0.002)	12.0 ± 0.30 (0.472 ± 0.012)		

NOTES:

- The cavity defined by A₀, B₀, and T shall be configured to provide sufficient clearance surrounding the component so that:
 - the component does not protrude beyond either surface of the carrier tape;
 - the component can be removed from the cavity in a vertical direction without mechanical restriction after the top cover tape has been removed;
 - rotation of the component is limited to 20° maximum (see Sketches A & B);
 - lateral movement of the component is restricted to 0.5mm maximum (see Sketch C).

- Tape with or without components shall pass around radius "R" without damage.
- Bar code labeling (if required) shall be on the side of the reel opposite the sprocket holes. Refer to EIA-556.
- If P₁ = 2.0mm, the tape may not properly index in all tape feeders.

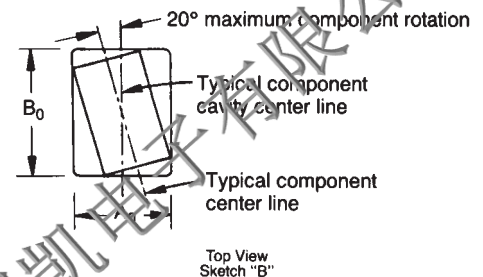
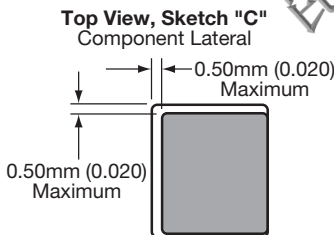
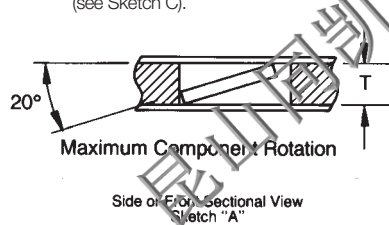

Bar Code Labeling Standard

AVX bar code labeling is available and follows latest version of EIA-556

BENEFITS

- Easier handling
- Smaller packaging volume (1/20 of T/R packaging)
- Easier inventory control
- Flexibility
- Recyclable

BULK FEEDER

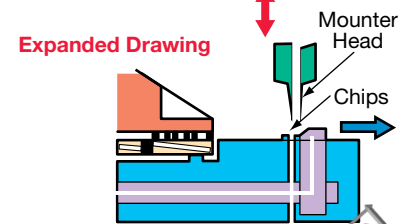
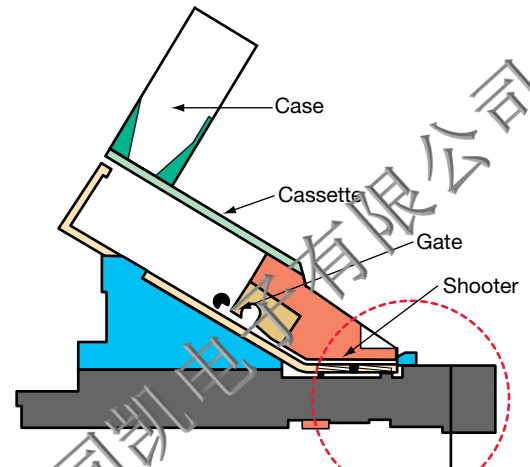

CASE DIMENSIONS

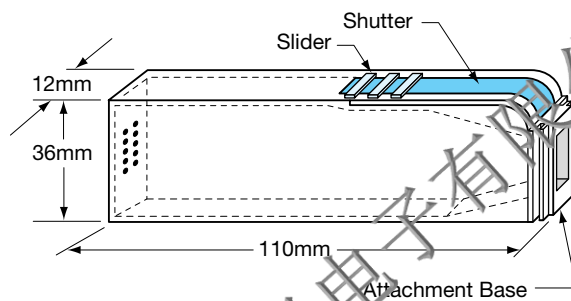

CASE QUANTITIES

Part Size	0402	0603	0805	1206
Qty. (pcs / cassette)	80,000	15,000	10,000 (T=.023") 8,000 (T=.031") 6,000 (T=.043")	5,000 (T=.023") 4,000 (T=.032") 3,000 (T=.044")

I. Capacitance (farads)

English: $C = \frac{.224 \text{ K.A.}}{T_D}$

Metric: $C = \frac{.0884 \text{ K.F.}}{T_D}$

II. Energy stored in capacitors (Joules, watt - sec)

$E = \frac{1}{2} C V^2$

III. Linear charge of a capacitor (Amperes)

$I = C \frac{dV}{dt}$

IV. Total Impedance of a capacitor (ohms)

$Z = \sqrt{R_s^2 + (X_C - X_L)^2}$

V. Capacitive Reactance (ohms)

$X_C = \frac{1}{2 \pi f C}$

VI. Inductive Reactance (ohms)

$X_L = 2 \pi f L$

VII. Phase Angles:

Ideal Capacitors: Current leads voltage 90°
 Ideal Inductors: Current lags voltage 90°
 Ideal Resistors: Current in phase with voltage

VIII. Dissipation Factor (%)

D.F. = $\tan \delta$ (loss angle) = $\frac{E.S.R.}{X_C} = (2 \pi f C) (E.S.R.)$

IX. Power Factor (%)

P.F. = $\text{Sine } \delta$ (loss angle) = $\text{Cos } \phi$ (phase angle)
 P.F. = (when less than 10%) = DF

X. Quality Factor (dimensionless)

$Q = \text{Cotan } \delta$ (loss angle) = $\frac{1}{D.F.}$

XI. Equivalent Series Resistance (ohms)

E.S.R. = (D.F.) (Xc) = (D.F.) / (2 π fC)

XII. Power Loss (watts)

Power Loss = (2 π fCV²) (D.F.)

XIII. KVA (Kilowatts)

KVA = 2 π fCV² x 10⁻³

XIV. Temperature Characteristic (ppm/°C)

T.C. = $\frac{C_t - C_{25}}{C_{25} (T_t - 25)} \times 10^6$

XV. Cap Drift (%)

C.D. = $\frac{C_1 - C_2}{C_1} \times 100$

XVI. Reliability of Ceramic Capacitors

$\frac{L_o}{L_t} = \left(\frac{V_t}{V_o} \right)^X \left(\frac{T_t}{T_o} \right)^Y$

XVII. Capacitors in Series (current the same)

Any Number: $\frac{1}{C_T} = \frac{1}{C_1} + \frac{1}{C_2} \dots \frac{1}{C_N}$

Two: $C_T = \frac{C_1 C_2}{C_1 + C_2}$

XVIII. Capacitors in Parallel (voltage the same)

$C_T = C_1 + C_2 \dots + C_N$

XIX. Aging Rate

A.R. = %Δ C/decade of time

XX. Decibels

db = 20 log $\frac{V_1}{V_2}$

METRIC PREFIXES

SYMBOLS

Pico	X 10 ⁻¹²
Nano	X 10 ⁻⁹
Micro	X 10 ⁻⁶
Milli	X 10 ⁻³
Deci	X 10 ⁻¹
Deca	X 10 ⁺¹
Kilo	X 10 ⁺³
Mega	X 10 ⁺⁶
Giga	X 10 ⁺⁹
Tera	X 10 ⁺¹²

K = Dielectric Constant	f = frequency	L _t = Test life
A = Area	L = Inductance	V _t = Test voltage
T _D = Dielectric thickness	δ = Loss angle	V _o = Operating voltage
V = Voltage	φ = Phase angle	T _t = Test temperature
t = time	X & Y = exponent effect of voltage and temp.	T _o = Operating temperature
R _s = Series Resistance	L _o = Operating life	

Basic Construction – A multilayer ceramic (MLC) capacitor is a monolithic block of ceramic containing two sets of offset, interleaved planar electrodes that extend to two opposite surfaces of the ceramic dielectric. This simple

structure requires a considerable amount of sophistication, both in material and manufacture, to produce it in the quality and quantities needed in today's electronic equipment.

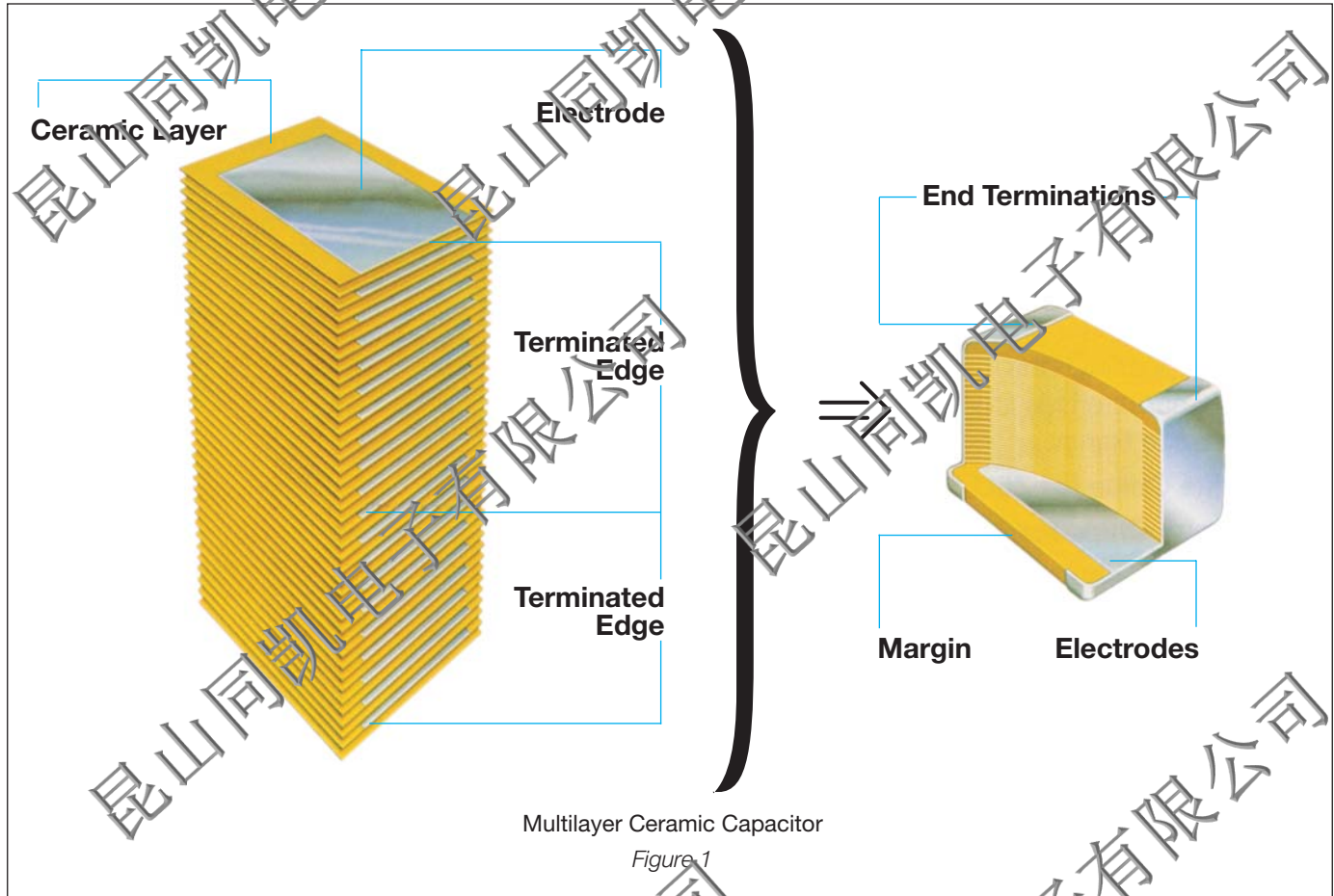

Formulations – Multilayer ceramic capacitors are available in both Class 1 and Class 2 formulations. Temperature compensating formulations are Class 1 and temperature stable and general application formulations are classified as Class 2.

Class 1 – Class 1 capacitors or temperature compensating capacitors are usually made from mixtures of titanates where barium titanate is normally not a major part of the mix. They have predictable temperature coefficients and in general, do not have an aging characteristic. Thus they are the most stable capacitor available. The most popular Class 1 multilayer ceramic capacitors are C0G (NP0) temperature compensating capacitors (negative-positive 0 ppm/°C).

Class 2 – EIA Class 2 capacitors typically are based on the chemistry of barium titanate and provide a wide range of capacitance values and temperature stability. The most commonly used Class 2 dielectrics are X7R and Y5V. The X7R provides intermediate capacitance values which vary only $\pm 15\%$ over the temperature range of -55°C to 125°C . It finds applications where stability over a wide temperature range is required.

The Y5V provides the highest capacitance values and is used in applications where limited temperature changes are expected. The capacitance value for Y5V can vary from 22% to -82% over the -30°C to 85°C temperature range.

All Class 2 capacitors vary in capacitance value under the influence of temperature, operating voltage (both AC and DC), and frequency. For additional information on performance changes with operating conditions, consult AVX's software, SpiCap.

Table 1: EIA and MIL Temperature Stable and General Application Codes

EIA CODE	
Percent Capacity Change Over Temperature Range	
RS198	Temperature Range
X7	-55°C to +125°C
X6	-55°C to +105°C
X5	-55°C to +85°C
Y5	-30°C to +85°C
Z5	+10°C to +85°C
Code	Percent Capacity Change
D	±3.3%
E	±4.7%
F	±7.5%
P	±10%
R	±15%
S	±22%
T	+22%, -33%
U	+22%, -56%
V	+22%, -82%

EXAMPLE – A capacitor is desired with the capacitance value at 25°C to increase no more than 7.5% or decrease no more than 7.5% from -30°C to +85°C. EIA Code will be Y5F.

MIL CODE		
Symbol	Temperature Range	
A	-55°C to +85°C	
B	-55°C to +125°C	
C	-55°C to +150°C	
Symbol	Cap. Change Zero Volts	Cap. Change Rated Volts
R	+15%, -15%	+15%, -40%
S	+22%, -22%	+22%, -56%
W	+22%, -56%	+22%, -82%
X	+15%, -15%	+15%, -25%
Y	+30%, -70%	+30%, -80%
Z	+20%, -20%	+20%, -30%

Temperature characteristic is specified by combining range and change symbols, for example BR or AW. Specification slash sheets indicate the characteristic applicable to a given style of capacitor.

In specifying capacitance change with temperature for Class 2 materials, EIA expresses the capacitance change over an operating temperature range by a 3 symbol code. The first symbol represents the cold temperature end of the temperature range, the second represents the upper limit of the operating temperature range and the third symbol represents the capacitance change allowed over the operating temperature range. Table 1 provides a detailed explanation of the EIA system.

Effects of Voltage – Variations in voltage have little effect on Class 1 dielectric but does affect the capacitance and dissipation factor of Class 2 dielectrics. The application of DC voltage reduces both the capacitance and dissipation factor while the application of an AC voltage within a reasonable range tends to increase both capacitance and dissipation factor readings. If a high enough AC voltage is applied, eventually it will reduce capacitance just as a DC voltage will. Figure 2 shows the effects of AC voltage.

Cap. Change vs. A.C. Volts X7R

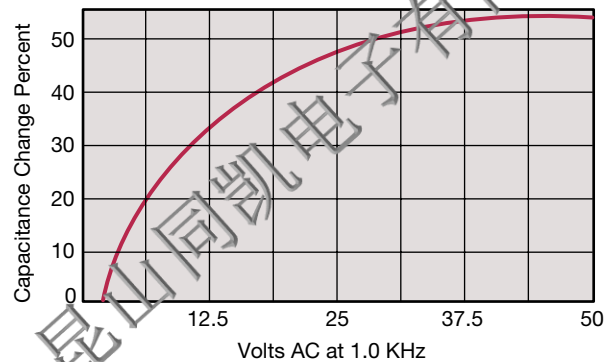

Figure 2

Capacitor specifications specify the AC voltage at which to measure (normally 0.5 or 1 VAC) and application of the wrong voltage can cause spurious readings. Figure 3 gives the voltage coefficient of dissipation factor for various AC voltages at 1 kilohertz. Applications of different frequencies will affect the percentage changes versus voltages.

D.F. vs. A.C. Measurement Volts X7R

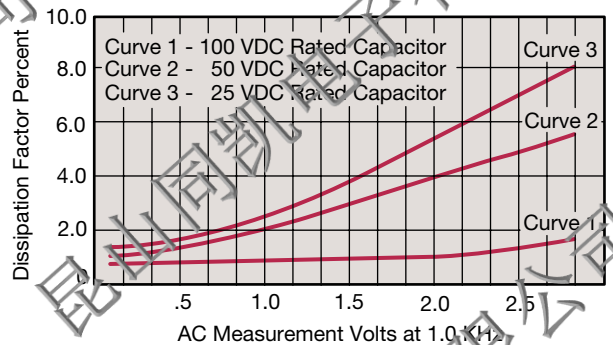

Figure 3

Typical effect of the application of DC voltage is shown in Figure 4. The voltage coefficient is more pronounced for higher K dielectrics. These figures are shown for room temperature conditions. The combination characteristic known as voltage temperature limits which shows the effects of rated voltage over the operating temperature range is shown in Figure 5 for the military BX characteristic.

Typical Cap. Change vs. D.C. Volts
X7R

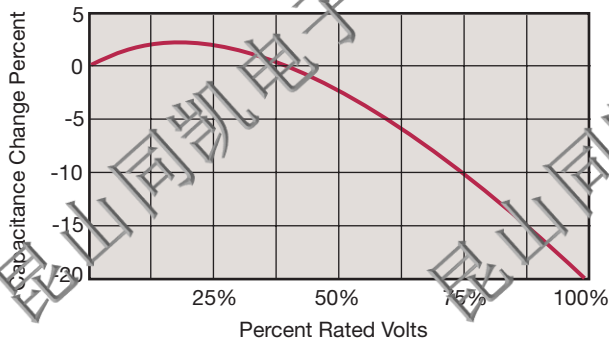

Figure 4

Typical Cap. Change vs. Temperature
X7R

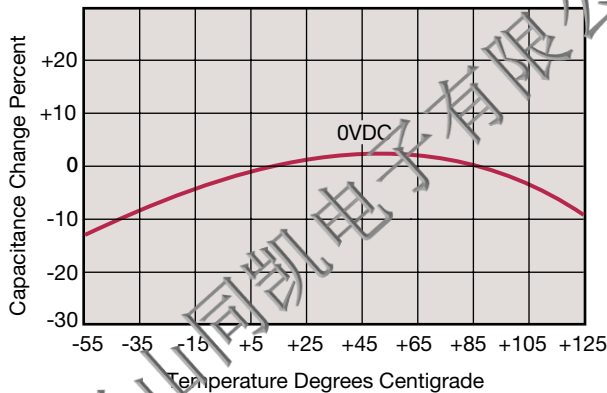

Figure 5

Effects of Time – Class 2 ceramic capacitors change capacitance and dissipation factor with time as well as temperature, voltage and frequency. This change with time is known as aging. Aging is caused by a gradual re-alignment of the crystalline structure of the ceramic and produces an exponential loss in capacitance and decrease in dissipation factor versus time. A typical curve of aging rate for semi-stable ceramics is shown in Figure 6.

If a Class 2 ceramic capacitor that has been sitting on the shelf for a period of time, is heated above its curie point, (125°C for 4 hours or 150°C for ½ hour will suffice) the part will de-age and return to its initial capacitance and dissipation factor readings. Because the capacitance changes rapidly, immediately after de-aging, the basic capacitance measurements are normally referred to a time period sometime after the de-aging process. Various manufacturers use different time bases but the most popular one is one day or twenty-four hours after “last heat.” Change in the aging curve can be caused by the application of voltage and other stresses. The possible changes in capacitance due to de-aging by heating the unit explain why capacitance changes are allowed after test, such as temperature cycling, moisture resistance, etc., in MIL specs. The application of high voltages such as dielectric withstanding voltages also

tends to de-age capacitors and is why re-reading of capacitance after 12 or 24 hours is allowed in military specifications after dielectric strength tests have been performed.

Typical Curve of Aging Rate
X7R

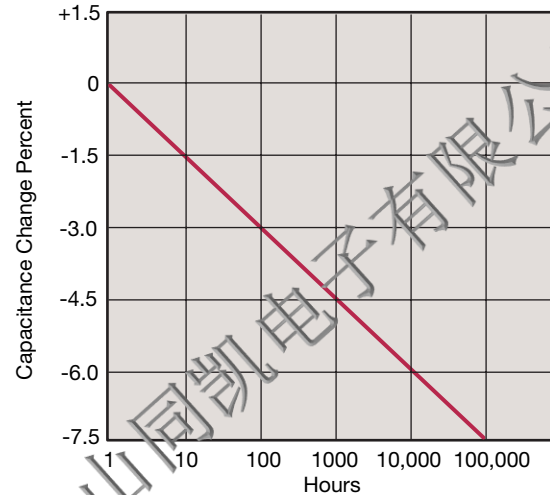

Characteristic	Max. Aging Rate %/Decade
C0G (NP0)	None
X7R, X5R	2
Y5V	7

Figure 6

Effects of Frequency – Frequency affects capacitance and impedance characteristics of capacitors. This effect is much more pronounced in high dielectric constant ceramic formulation than in low K formulations. AVX's SpiCap software generates impedance, ESR, series inductance, series resonant frequency and capacitance all as functions of frequency, temperature and DC bias for standard chip sizes and styles. It is available free from AVX and can be downloaded for free from AVX website: www.avx.com.

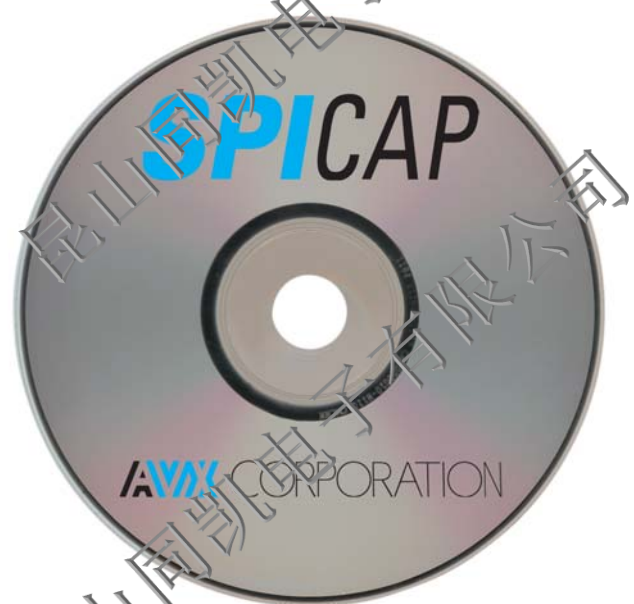

Effects of Mechanical Stress – High “K” dielectric ceramic capacitors exhibit some low-level piezoelectric reactions under mechanical stress. As a general statement, the piezoelectric output is higher, the higher the dielectric constant of the ceramic. It is desirable to investigate this effect before using high “K” dielectrics as coupling capacitors in extremely low-level applications.

Reliability – Historically ceramic capacitors have been one of the most reliable types of capacitors in use today. The approximate formula for the reliability of a ceramic capacitor is:

$$\frac{L_o}{L_t} = \left(\frac{V_t}{V_o}\right)^X \left(\frac{T_t}{T_o}\right)^Y$$

where

L_o = operating life T_t = test temperature and
 L_t = test life T_o = operating temperature
 V_t = test voltage in °C
 V_o = operating voltage X, Y = see text

Historically for ceramic capacitors exponent X has been considered as 3. The exponent Y for temperature effects typically tends to run about 8.

A capacitor is a component which is capable of storing electrical energy. It consists of two conductive plates (electrodes) separated by insulating material which is called the dielectric. A typical formula for determining capacitance is:

$$C = \frac{.224 KA}{t}$$

C = capacitance (picofarads)
 K = dielectric constant (Vacuum = 1)
 A = area in square inches
 t = separation between the plates in inches
 (thickness of dielectric)
 $.224$ = conversion constant
 (.0884 for metric system in cm)

Capacitance – The standard unit of capacitance is the farad. A capacitor has a capacitance of 1 farad when 1 coulomb charges it to 1 volt. One farad is a very large unit and most capacitors have values in the micro (10^{-6}), nano (10^{-9}) or pico (10^{-12}) farad level.

Dielectric Constant – In the formula for capacitance given above the dielectric constant of a vacuum is arbitrarily chosen as the number 1. Dielectric constants of other materials are then compared to the dielectric constant of a vacuum.

Dielectric Thickness – Capacitance is indirectly proportional to the separation between electrodes. Lower voltage requirements mean thinner dielectrics and greater capacitance per volume.

Area – Capacitance is directly proportional to the area of the electrodes. Since the other variables in the equation are usually set by the performance desired, area is the easiest parameter to modify to obtain a specific capacitance within a material group.

Energy Stored – The energy which can be stored in a capacitor is given by the formula:

$$E = \frac{1}{2}CV^2$$

E = energy in joules (watts-sec)
 V = applied voltage
 C = capacitance in farads

Potential Change – A capacitor is a reactive component which reacts against a change in potential across it. This is shown by the equation for the linear charge of a capacitor:

$$I_{ideal} = C \frac{dV}{dt}$$

where

I = Current
 C = Capacitance
 dV/dt = Slope of voltage transition across capacitor

Thus an infinite current would be required to instantly change the potential across a capacitor. The amount of current a capacitor can “sink” is determined by the above equation.

Equivalent Circuit – A capacitor, as a practical device, exhibits not only capacitance but also resistance and inductance. A simplified schematic for the equivalent circuit is:

C = Capacitance L = Inductance
 R_s = Series Resistance R_p = Parallel Resistance

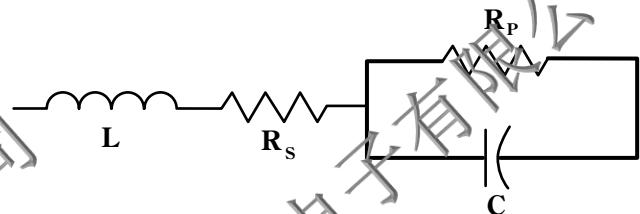

Reactance – Since the insulation resistance (R_p) is normally very high, the total impedance of a capacitor is:

$$Z = \sqrt{R_s^2 + (X_c - X_L)^2}$$

where

Z = Total Impedance
 R_s = Series Resistance
 X_c = Capacitive Reactance = $\frac{1}{2\pi fC}$
 X_L = Inductive Reactance = $2\pi fL$

The variation of a capacitor’s impedance with frequency determines its effectiveness in many applications.

Phase Angle – Power Factor and Dissipation Factor are often confused since they are both measures of the loss in a capacitor under AC application and are often almost identical in value. In a “perfect” capacitor the current in the capacitor will lead the voltage by 90°.

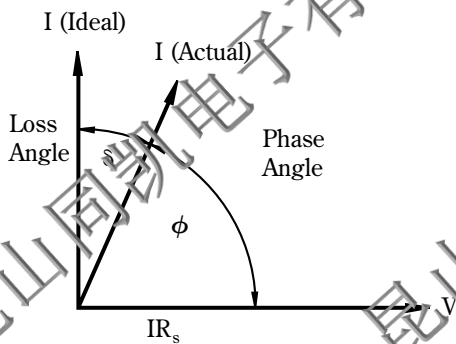

In practice the current leads the voltage by some other phase angle due to the series resistance R_s . The complement of this angle is called the loss angle and:

$$\text{Power Factor (P.F.)} = \cos \phi \text{ or } \sin \delta$$

$$\text{Dissipation Factor (D.F.)} = \tan \delta$$

for small values of δ the tan and sine are essentially equal which has led to the common interchangeability of the two terms in the industry.

Equivalent Series Resistance – The term E.S.R. or Equivalent Series Resistance combines all losses both series and parallel in a capacitor at a given frequency so that the equivalent circuit is reduced to a simple R-C series connection.

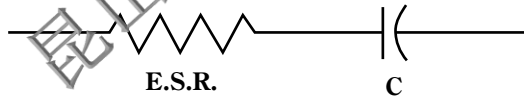

Dissipation Factor – The DF/PF of a capacitor tells what percent of the apparent power input will turn to heat in the capacitor.

$$\text{Dissipation Factor} = \frac{\text{E.S.R.}}{X_c} = (2 \pi fC) (\text{E.S.R.})$$

The watts loss are:

$$\text{Watts loss} = (2 \pi fCV^2) (\text{D.F.})$$

Very low values of dissipation factor are expressed as their reciprocal for convenience. These are called the “Q” or Quality factor of capacitors.

Parasitic Inductance – The parasitic inductance of capacitors is becoming more and more important in the decoupling of today’s high speed digital systems. The relationship between the inductance and the ripple voltage induced on the DC voltage line can be seen from the simple inductance equation:

$$V = L \frac{di}{dt}$$

The $\frac{di}{dt}$ seen in current microprocessors can be as high as 0.3 A/ns, and up to 10A/ns. At 0.3 A/ns, 100pH of parasitic inductance can cause a voltage spike of 30mV. While this does not sound very drastic, with the V_{cc} for microprocessors decreasing at the current rate, this can be a fairly large percentage.

Another important, often overlooked, reason for knowing the parasitic inductance is the calculation of the resonant frequency. This can be important for high frequency, bypass capacitors, as the resonant point will give the most signal attenuation. The resonant frequency is calculated from the simple equation:

$$f_{res} = \frac{1}{2\pi\sqrt{LC}}$$

Insulation Resistance – Insulation Resistance is the resistance measured across the terminals of a capacitor and consists principally of the parallel resistance R_P shown in the equivalent circuit. As capacitance values and hence the area of dielectric increases, the I.R. decreases and hence the product ($C \times IR$ or RC) is often specified in ohm farads or more commonly megohm-microfarads. Leakage current is determined by dividing the rated voltage by IR (Ohm’s Law).

Dielectric Strength – Dielectric Strength is an expression of the ability of a material to withstand an electrical stress. Although dielectric strength is ordinarily expressed in volts, it is actually dependent on the thickness of the dielectric and thus is also more generically a function of volts/mil.

Dielectric Absorption – A capacitor does not discharge instantaneously upon application of a short circuit, but drains gradually after the capacitance proper has been discharged. It is common practice to measure the dielectric absorption by determining the “reappearing voltage” which appears across a capacitor at some point in time after it has been fully discharged under short circuit conditions.

Corona – Corona is the ionization of air or other vapors which causes them to conduct current. It is especially prevalent in high voltage units but can occur with low voltages as well where high voltage gradients occur. The energy discharged degrades the performance of the capacitor and can in time cause catastrophic failures.

Surface Mounting Guide



MLC Chip Capacitors

REFLOW SOLDERING

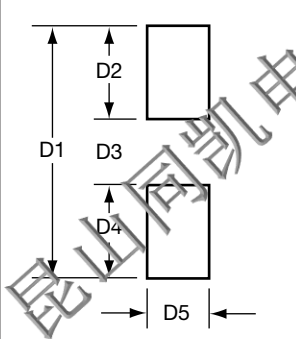

Case Size	D1	D2	D3	D4	D5
0201	0.85 (0.033)	0.30 (0.012)	0.25 (0.010)	0.30 (0.014)	0.35 (0.014)
0402	1.70 (0.067)	0.60 (0.024)	0.50 (0.020)	0.60 (0.024)	0.50 (0.020)
0603	2.30 (0.091)	0.80 (0.031)	0.70 (0.028)	0.80 (0.031)	0.75 (0.030)
0805	3.00 (0.118)	1.00 (0.039)	1.00 (0.039)	1.00 (0.039)	1.25 (0.049)
1206	4.00 (0.157)	1.00 (0.039)	2.00 (0.079)	1.00 (0.039)	1.60 (0.063)
1210	4.00 (0.157)	1.00 (0.039)	2.00 (0.079)	1.00 (0.039)	2.50 (0.098)
1808	5.60 (0.220)	1.00 (0.039)	3.60 (0.142)	1.00 (0.039)	2.00 (0.079)
1812	5.60 (0.220)	1.00 (0.039)	3.60 (0.142)	1.00 (0.039)	3.00 (0.118)
1825	5.60 (0.220)	1.00 (0.039)	3.60 (0.142)	1.00 (0.039)	6.35 (0.250)
2220	6.60 (0.260)	1.00 (0.039)	4.60 (0.181)	1.00 (0.039)	5.00 (0.197)
2225	6.60 (0.260)	1.00 (0.039)	4.60 (0.181)	1.00 (0.039)	6.35 (0.250)

Dimensions in millimeters (inches)

Component Pad Design

Component pads should be designed to achieve good solder fillets and minimize component movement during reflow soldering. Pad designs are given below for the most common sizes of multilayer ceramic capacitors for both wave and reflow soldering. The basis of these designs is:

- Pad width equal to component width. It is permissible to decrease this to as low as 85% of component width but it is not advisable to go below this.
- Pad overlap 0.5mm beneath component.
- Pad extension 0.5mm beyond components for reflow and 1.0mm for wave soldering.

WAVE SOLDERING

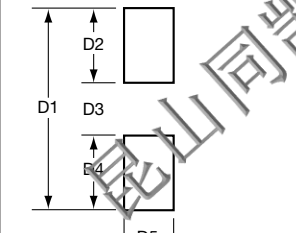

Case Size	D1	D2	D3	D4	D5
0603	3.10 (0.12)	1.20 (0.05)	0.70 (0.03)	1.20 (0.05)	0.75 (0.03)
0805	4.00 (0.15)	1.50 (0.06)	1.00 (0.04)	1.50 (0.06)	1.25 (0.05)
1206	5.00 (0.19)	1.50 (0.06)	2.00 (0.09)	1.50 (0.06)	1.60 (0.06)

Dimensions in millimeters (inches)

Component Spacing

For wave soldering components, must be spaced sufficiently far apart to avoid bridging or shadowing (inability of solder to penetrate properly into small spaces). This is less important for reflow soldering but sufficient space must be allowed to enable rework should it be required.

Preheat & Soldering

The rate of preheat should not exceed 4°C/second to prevent thermal shock. A better maximum figure is about 2°C/second.

For capacitors size 1206 and below, with a maximum thickness of 1.25mm, it is generally permissible to allow a temperature differential from preheat to soldering of 150°C. In all other cases this differential should not exceed 100°C.

For further specific application or process advice, please consult AVX.

Cleaning

Care should be taken to ensure that the capacitors are thoroughly cleaned of flux residues especially the space beneath the capacitor. Such residues may otherwise become conductive and effectively offer a low resistance bypass to the capacitor.

Ultrasonic cleaning is permissible, the recommended conditions being 8 Watts/litre at 20-45 kHz, with a process cycle of 2 minutes vapor rinse, 2 minutes immersion in the ultrasonic solvent bath and finally 2 minutes vapor rinse.

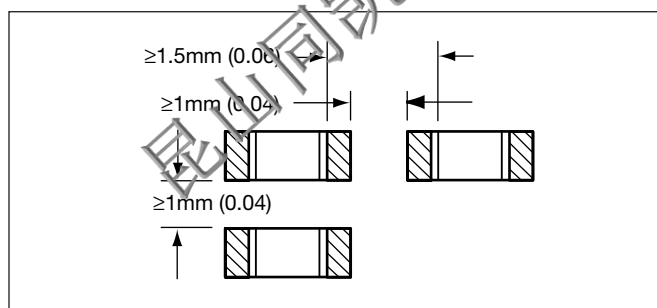

Recommended Soldering Profiles

REFLOW SOLDER PROFILES

AVX RoHS compliant products utilize termination finishes (e.g. Sn or SnAg) that are compatible with all Pb-Free soldering systems and are fully reverse compatible with SnPb soldering systems. A recommended SnPb profile is shown for comparison; for Pb-Free soldering, IPC/JEDECJ-STD-020C may be referenced. The upper line in the chart shows the maximum envelope to which products are qualified (typically 3x reflow cycles at 260°C max). The center line gives the recommended profile for optimum wettability and soldering in Pb-Free Systems.

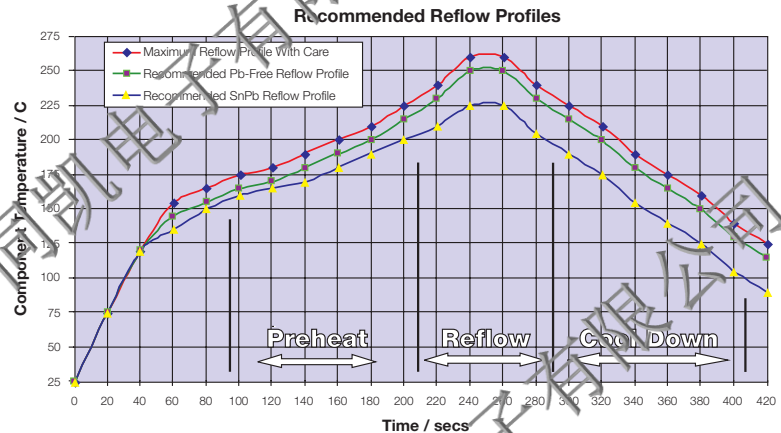

Preheat:

The pre-heat stabilizes the part and reduces the temperature differential prior to reflow. The initial ramp to 125°C may be rapid, but from that point (2-3)°C/sec is recommended to allow ceramic parts to heat uniformly and plastic encapsulated parts to stabilize through the glass transition temperature of the body (~ 180°C).

Reflow:

In the reflow phase, the maximum recommended time > 230°C is 40secs. Time at peak reflow is 10secs max.; optimum reflow is achieved at 250°C, (see wetting balance chart opposite) but products are qualified to 260°C max. Please reference individual product datasheets for maximum limits

Cool Down:

Cool down should not be forced and 6°C/sec is recommended. A slow cool down will result in a finer grain structure of the reflow solder in the solder fillet.

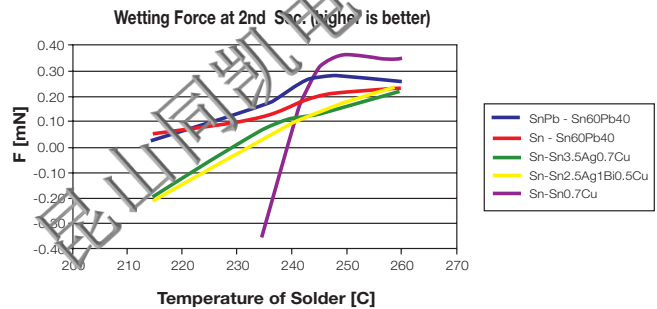

IMPORTANT NOTE: Typical Pb-Free reflow solders have a more dull and grainy appearance compared to traditional SnPb. Elevating the reflow temperature will not change this, but extending the cool down can help improve the visual appearance of the joint.

WAVE SOLDER PROFILES

For wave solder, there is no change in the recommended wave profile; all standard Pb-Free (SnCu/SnCuAg) systems operate at the same 260°C max recommended for SnPb systems.

Preheat:

This is more important for wave solder; a higher temperature preheat will reduce the thermal shock to SMD parts that are immersed (please consult individual product data sheets for SMD parts that are suited to wave solder). SMD parts should ideally be heated from the bottom-Side prior to wave. PTH (Pin through hole) parts on the topside should not be separately heated.

Wave:

250°C – 260°C recommended for optimum solderability.

Cool Down:

As with reflow solder, cool down should not be forced and 6°C/sec is recommended. Any air knives at the end of the 2nd wave should be heated.

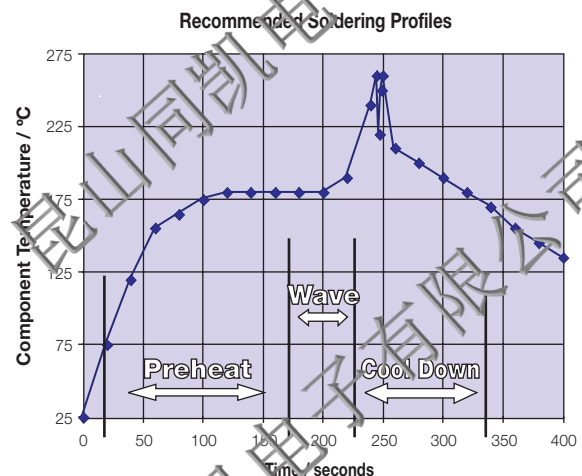

Surface Mounting Guide



MLC Chip Capacitors

APPLICATION NOTES

Storage

Good solderability is maintained for at least twelve months, provided the components are stored in their "as received" packaging at less than 40°C and 70% RH.

Solderability

Terminations to be well soldered after immersion in a 60/40 tin/lead solder bath at $235 \pm 5^\circ\text{C}$ for 2 ± 1 seconds.

Leaching

Terminations will resist leaching for at least the immersion times and conditions shown below.

Termination Type	Solder Tin/Lead/Silver	Solder Temp. °C	Immersion Time Seconds
Nickel Barrier	60/40/0	260 ± 5	30 ± 1

Lead-Free Wave Soldering

The recommended peak temperature for lead-free wave soldering is 250°C - 260°C for 3-5 seconds. The other parameters of the profile remains the same as above.

The following should be noted by customers changing from lead based systems to the new lead-free pastes.

- The visual standards used for evaluation of solder joints will need to be modified as lead-free joints are not as bright as with tin-lead pastes and the fillet may not be as large.
- Lead-free solder pastes do not allow the same self alignment as lead containing systems. Standard mounting pads are acceptable, but machine set up may need to be modified.

General

Surface mounting chip multilayer ceramic capacitors are designed for soldering to printed circuit boards or other substrates. The construction of the components is such that they will withstand the time/temperature profiles used in both wave and reflow soldering methods.

Handling

Chip multilayer ceramic capacitors should be handled with care to avoid damage or contamination from perspiration and skin oils. The use of tweezers or vacuum pick ups is strongly recommended for individual components. Bulk handling should ensure that abrasion and mechanical shock

are minimized. Taped and reeled components provides the ideal medium for direct presentation to the placement machine. Any mechanical shock should be minimized during handling chip multilayer ceramic capacitors.

Preheat

It is important to avoid the possibility of thermal shock during soldering and carefully controlled preheat is therefore required. The rate of preheat should not exceed $4^\circ\text{C}/\text{second}$ and a target figure $2^\circ\text{C}/\text{second}$ is recommended. Although an 80°C to 120°C temperature differential is preferred, recent developments allow a temperature differential between the component surface and the soldering temperature of 150°C (Maximum) for capacitors of 1210 size and below with a maximum thickness of 1.25mm. The user is cautioned that the risk of thermal shock increases as chip size or temperature differential increases.

Soldering

Mildly activated rosin fluxes are preferred. The minimum amount of solder to give a good joint should be used. Excessive solder can lead to damage from the stresses caused by the difference in coefficients of expansion between solder, chip and substrate. AVX terminations are suitable for all wave and reflow soldering systems. If hand soldering cannot be avoided, the preferred technique is the utilization of hot air soldering tools.

Cooling

Natural cooling in air is preferred, as this minimizes stresses within the soldered joint. When forced air cooling is used, cooling rate should not exceed $4^\circ\text{C}/\text{second}$. Quenching is not recommended but if used, maximum temperature differentials should be observed according to the preheat conditions above.

Cleaning

Flux residues may be hygroscopic or acidic and must be removed. AVX MLC capacitors are acceptable for use with all of the solvents described in the specifications MIL-STD-202 and EIA-RS-198. Alcohol based solvents are acceptable and properly controlled water cleaning systems are also acceptable. Many other solvents have been proven successful, and most solvents that are acceptable to other components on circuit assemblies are equally acceptable for use with ceramic capacitors.

Surface Mounting Guide



MLC Chip Capacitors

POST SOLDER HANDLING

Once SMD components are soldered to the board, any bending or flexure of the PCB applies stresses to the soldered joints of the components. For leaded devices, the stresses are absorbed by the compliancy of the metal leads and generally don't result in problems unless the stress is large enough to fracture the soldered connection.

Ceramic capacitors are more susceptible to such stress because they don't have compliant leads and are brittle in nature. The most frequent failure mode is low DC resistance or short circuit. The second failure mode is significant loss of capacitance due to severing of contact between sets of the internal electrodes.

Cracks caused by mechanical flexure are very easily identified and generally take one of the following two general forms:

Mechanical cracks are often hidden underneath the termination and are difficult to see externally. However, if one end termination falls off during the removal process from PCB, this is one indication that the cause of failure was excessive mechanical stress due to board warping.



Type A:
Angled crack between bottom of device to top of solder joint.

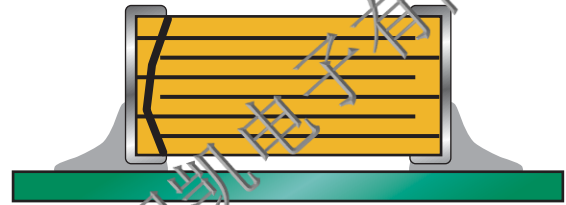

Type B:
Fracture from top of device to bottom of device.

COMMON CAUSES OF MECHANICAL CRACKING

The most common source for mechanical stress is board depanelization equipment, such as manual breakapart, v-cutters and shear presses. Improperly aligned or dull cutters may cause torquing of the PCB resulting in flex stresses being transmitted to components near the board edge. Another common source of flexural stress is contact during parametric testing when test points are probed. If the PCB is allowed to flex during the test cycle, nearby ceramic capacitors may be broken.

A third common source is board to board connections at vertical connectors where cables or other PCBs are connected to the PCB. If the board is not supported during the plug/unplug cycle, it may flex and cause damage to nearby components.

Special care should also be taken when handling large (>6" on a side) PCBs since they more easily flex or warp than smaller boards.

REWORKING OF MLCs

Thermal shock is common in MLCs that are manually attached or reworked with a soldering iron. *AVX strongly recommends that any reworking of MLCs be done with hot air reflow rather than soldering irons.* It is practically impossible to cause any thermal shock in ceramic capacitors when using hot air reflow.

However direct contact by the soldering iron tip often causes thermal cracks that may fail at a later date. If rework by soldering iron is absolutely necessary, it is recommended that the wattage of the iron be less than 30 watts and the tip temperature be <300°C. *Rework should be performed by applying the solder iron tip to the pad and not directly contacting any part of the ceramic capacitor.*

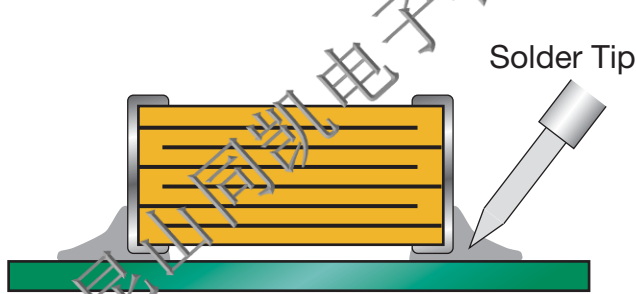

Preferred Method - No Direct Part Contact

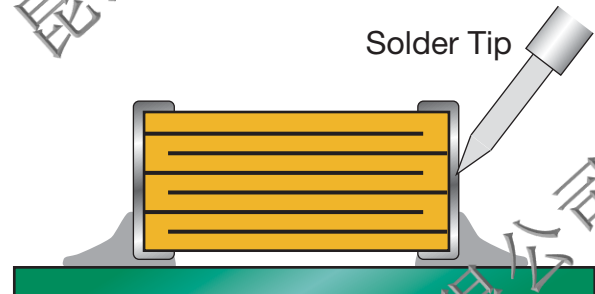

Poor Method - Direct Contact with Part

PCB BOARD DESIGN

To avoid many of the handling problems, AVX recommends that MLCs be located at least .2" away from nearest edge of board. However when this is not possible, AVX recommends that the panel be routed along the cut line, adjacent to where the MLC is located.

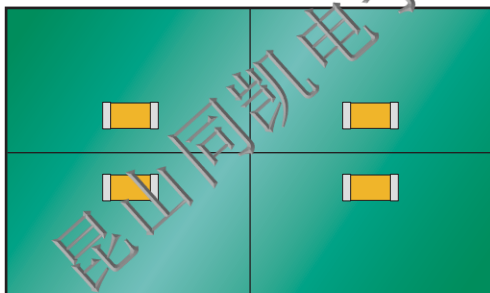

No Stress Relief for MLCs

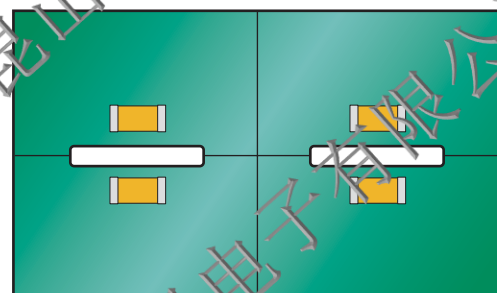

Routed Cut Line Relieves Stress on MLC

AMERICAS

**AVX Myrtle Beach, SC
Corporate Offices**
Tel: 843-448-9411
FAX: 843-448-1943

AVX Northwest, WA
Tel: 360-699-8746
FAX: 360-699-8751

AVX North Central, IN
Tel: 317-848-7153
FAX: 317-848-9314

AVX Midwest, MN
Tel: 952-974-9155
FAX: 952-974-9179

AVX Mid/Pacific, CA
Tel: 510-661-4100
FAX: 510-661-4101

AVX Northeast, MA
Tel: 617-479-0345
FAX: 843-916-7614

AVX Southwest, AZ
Tel: 602-678-0384
FAX: 602-678-0385

AVX South Central, TX
Tel: 214-566-2859
FAX: 972-461-0575

AVX Southeast, GA
Tel: 404-608-8151
FAX: 770-972-0766

AVX Canada

Tel: 905-238-3151
FAX: 905-238-0319

AVX South America

Tel: ++55-11-2193-7200
FAX: ++55-11-2193-7210

EUROPE

**AVX Limited, England
European Headquarters**
Tel: ++44 (0) 1252-770000
FAX: ++44 (0) 1252-770001

AVX/ELCO, England
Tel: ++44 (0) 1638-675000
FAX: ++44 (0) 1638-675002

AVX S.A., France
Tel: ++33 (1) 69-18-46-00
FAX: ++33 (1) 69-28-73-87

AVX GmbH, Germany
Tel: ++49 (0) 8131-9004-0
FAX: ++49 (0) 8131-9004-44

AVX srl, Italy

Tel: ++390 (0)2 614-571
FAX: ++390 (0)2 614-2576

AVX Czech Republic

Tel: ++420 57 57 57 521
FAX: ++420 57 57 57 109

ASIA-PACIFIC

**AVX/Kyocera, Singapore
Asia-Pacific Headquarters**
Tel: (65) 6786-7555
FAX: (65) 6488-9880

AVX/Kyocera, Hong Kong
Tel: (852) 2-363-3303
FAX: (852) 2-765-8185

AVX/Kyocera, Korea
Tel: (82) 2-785-6504
FAX: (82) 2-784-5411

AVX/Kyocera, Taiwan
Tel: (886) 2-2698-8778
FAX: (886) 2-2698-8777

AVX/Kyocera, Malaysia

Tel: (60) 4-228-1190
FAX: (60) 4-228-1196

Elco, Japan

Tel: 045-943-2906/7
FAX: 045-943-2910

Kyocera, Japan - AVX

Tel: (81) 75-604-3426
FAX: (81) 75-604-3425

Kyocera, Japan - KDP

Tel: (81) 75-604-3424
FAX: (81) 75-604-3425

**AVX/Kyocera, Shanghai,
China**

Tel: 86-21 6341 0300
FAX: 86-21 6341 0330

AVX/Kyocera, Beijing, China

Tel: 86-10 8458 3385
Fax: 86-10 8458 3382

ASIA-KED

KED, Hong Kong
Tel: (852) 2305 1080
FAX: (852) 2305 1405

KED, Shanghai
Tel: (86) 21 6859 9898
FAX: (86) 21 5887 2542

KED, Beijing
Tel: (86) 10 5869 4655
FAX: (86) 10 5869 4677

KED, South Korea
Tel: (82) 2 783 3288
FAX: (82) 2 783 3207

KED, Taiwan
Tel: (886) 2 2950 0268
FAX: (886) 2 2950 0520

KED, Singapore
Tel: (65) 6255 3122
FAX: (65) 6255 5092

Contact: