

PRODUCT DESCRIPTION

KEMET's family of solid tantalum chip capacitors is designed and manufactured with the demanding requirements of surface mount technology in mind.

These devices extend the advantages of solid tantalum technology to today's surface mount circuit applications. Complementing multilayer ceramic chip convenience with capacitance ratings through 1500 μF , tantalum chip capacitors permit circuit designers to take full advantage of the benefits of surface mount technology.

T491 Series — Industrial

The leading choice in today's surface mount designs is the KEMET T491 Series. This product meets or exceeds the requirements of EIA standard 535BAAC. The physical outline and dimensions of this series conform to this global standard.

Five low profile case sizes have been added to the T491 family. The R/2012-12, S/3216-12 and T/3528-12 case sizes have a maximum height of 1.2 mm. The U/6032-15 size has a maximum height of 1.5 mm, and the V/7343-20 has a maximum height of 2.0 mm.

This product was designed specifically for today's highly automated surface mount processes and equipment. This series uses the same proven solid tantalum KEMET technology acclaimed and respected throughout the world. Added to this is the latest in materials, processes and automation which result in a component unsurpassed worldwide in total performance and value.

The standard terminations are 100% matte tin and provide excellent wetting characteristics and compatibility with today's surface mount solder systems. Tin-Lead (SnPb) terminations are available upon request for any part number. Gold-plated terminations are also available for use with conductive epoxy attachment processes. The symmetrical terminations offer total compliancy to provide the thermal and mechanical stress relief required in today's technology. Lead frame attachments to the tantalum pellet are made via a microprocessor-controlled welding operation, and a high temperature silver epoxy adhesive system.

Standard packaging of these devices is tape and reel in accordance with EIA 481-1. This system provides perfect compatibility with all tape-fed placement units.

T492 Series — Military

KEMET is approved to MIL-PRF-55365/8 (CWR11), Weibull failure rate "B" level or 0.1% failures per 1,000 hours, "C" level or 0.01% failures per 1,000 hours, and "D" level or 0.001% failures per 1,000 hours. This CWR11 product — designated as KEMET's T492 Series — is a precision-molded device, with compliant leadframe terminations and indelible laser marking. This is the military version of the global IEC/EIA standard represented by KEMET's T491 Series. Tape and reeling per EIA 481-1 is standard.

T493 Series — Military - COTS

The T493 series is designed for the COTS (Commercial-Off-The-Shelf) requirements of military/aerospace applications. This series is a surface mount tantalum product offering various lead-frame surface finishes, Weibull grading and surge current testing options. The full part number includes a code defining the terminations, the Weibull reliability, surge test conditions, and the ESR range. The possible terminations include gold plated, hot solder dipped, solder plated, and solder fused. Reliability grading of B level (0.1%/kHours) and C level (0.01%/kHours) are available. Surge current testing options include: 10 cycles at 25°C, or 10-cycles at -55°C and +85°C. Both standard and low ESR options are available. All lots of this series are conditioned with MIL-PRF-55365 Group A testing.

T494 Series — Low ESR, Industrial Grade

The T494 is a low ESR series that is available in all the same case sizes and CV ratings as the popular T491 series. The T494 offers low ESR performance with the economy of an industrial grade device. This series is targeted for output filtering and other applications that may benefit from improved efficiency due to low ESR.

T495 Series — Low ESR, Surge Robust

The low ESR, surge robust T495 series is an important member of KEMET's tantalum chip family. Designed primarily for output filtering in switch-mode power supplies and DC-to-DC converters, the standard CV T495 values are also an excellent choice for battery-to-ground input filter applications.

This series builds upon proven technology used for industrial grade tantalum chip capacitors to offer several important advantages: very low ESR, high ripple current capability, excellent capacitance stability, plus improved ability to withstand high inrush currents. These benefits are achieved through a combination of proprietary design, material, and process parameters, as well as high-stress, low impedance electrical conditioning performed prior to screening. Capacitance values range from 4.7 μF to 1000 μF , in voltage ratings from 4 to 50.

T496 Series — Fused

KEMET also offers a "fail-safe" fused solid tantalum chip capacitor. The built-in fuse element provides excellent protection from damaging short circuit conditions in applications where high fault currents exist. Protection from costly circuit damage due to reversed installation is offered with this device. Package sizes include the EIA standard 3528-12, 6032-15, 7343-31, and 7343-43 case size. Capacitance values range from 0.15 μF to 4700 μF , in voltage ratings from 4 to 50. Standard capacitance tolerances include $\pm 20\%$ and $\pm 10\%$. Tape and reeling per EIA 481-1 is standard.

PRODUCT DESCRIPTION

T510 Series — Ultra-Low ESR

The ultra-low ESR T510 Series is a breakthrough in solid tantalum capacitor technology. KEMET's T510 Series offers the low ESR in the popular EIA 7343-43 and 7360-38 case sizes. The ultra-low ESR and high ripple current capability make the T510 an ideal choice for SMPS filtering and power decoupling of today's high speed microprocessors.

KEMET has developed an innovative construction platform that incorporates multiple capacitor elements, in parallel, inside a single package. This unique assembly, combined with KEMET's superior processing technology, provides the best combination of high CV, low ESR, and small size in a user friendly, molded, surface mount package.

T520 SERIES — Organic Polymer Tantalum

The KO-CAP is a Tantalum capacitor, with Ta anode and Ta₂O₅ dielectric. However, a conductive organic, polymer replaces the MnO₂ as the cathode plate of the capacitor. This results in very low ESR and improved cap retention at high frequency. The KO-CAP also exhibits a benign failure mode, which eliminates the ignition failures that can occur in standard MnO₂ Tantalum types. Note also that KO-CAPs may be operated at voltages up to 90% of rated voltage for part types with rated voltage ≤ 10 volts and up to 80% of rated voltage for part types > 10 volts with equivalent or better reliability than standard tantalums operated at 50% of rated voltage.

The T520 series captures the best features of multilayer ceramic caps (low ESR and high frequency cap retention), aluminum electrolytics (benign failure mode), and proven solid tantalum technology (volumetric efficiency, surface mount capability, and no wearout mechanism). The KO-CAP can reduce component counts, eliminate through-hole assembly by replacing cumbersome leaded aluminum capacitors, and offer a more cost effective solution to high-cost high-cap ceramic capacitors. These benefits allow the designer to save both board space and money. See pages 40-45 for complete details.

T525 SERIES — High Temperature Organic Polymer

The T525 Series is a version of KEMET's Tantalum Polymer Capacitor rated up to 125°C. This part type was introduced as Lead (Pb) Free and offers the same advantages as to KO-CAP. This includes low ESR, high frequency capacitance retention and benign failure mode.

T530 SERIES — Organic Polymer Multiple Anode

KEMET is offering a multiple anode tantalum chip capacitor with a polymer material replacing the MnO₂ offering non-ignition, self-healing, 125°C performance capability with higher conductivity material that lowers the ESR. Packaged as multiple anodes to reduce the depth that the signal must penetrate, this parallel arrangement reduces the ESR further still to achieve the highest capacitance and lowest ESR of any other type of SMT capacitor with typical ESR of 7 milliohms. With the reduced ESR, the enhanced capacitance retention in higher frequencies results in the lowest total capacitance solution and provides for the most economical solution in high power applications.

TANTALUM MnO₂ COMPONENT PERFORMANCE CHARACTERISTICS

Introduction

KEMET solid tantalum capacitors are identified by the initial "T," followed by a unique "Series" number; for example, T491, T492, etc. Each Series denotes a general physical form and type of encapsulation, as well as limits on dimensions and certain electrical characteristics under standard conditions of 25 °C, 50% relative humidity, and one atmosphere pressure. Specific requirements are set forth in the respective Product Series in this catalog. All series are 100% screened for leakage, capacitance, dissipation factor, and ESR. All Series are inspected to electrical limits using a minimum .1% AQL sampling plan, according to the Military Standard MIL-STD-105, even after 100% testing. This sampling plan, to the best of KEMET Electronics' knowledge, meets or exceeds the generally accepted industry standard for similar products. KEMET capacitors may also be supplied, with prior agreement, to meet specifications with requirements differing from those of KEMET catalogs.

ELECTRICAL

1. General Application Class

Solid tantalum capacitors are usually applied in circuits where the AC component is small compared to the DC component. Typical uses known to KEMET Electronics include blocking, by-passing, decoupling, and filtering. They are also used in timing circuits. General purpose devices are recommended to have an external series resistance of 0.1Ω/volt to reduce the failure due to surge current. Newer devices designed for power applications (T495, T5XX), are built to eliminate this series resistance requirement. Because tantalum capacitors can experience scintillation (self-healing) in their life, the circuit impedance should not exceed 100KΩ or this will circumvent the scintillation and degrade leakage.

2. Operating Temperature Range

- -55 °C to +125 °C

Voltage derating is specified in Section 5. Performance characteristics over this temperature range are presented within the following sections.

3. Non-Operating Temperature Range

- -55 °C to +125 °C

Tantalum capacitors do not lose capacitance from the "de-forming" effect as do liquid-electrolytic capacitors. Storage at high temperature may cause a small, temporary increase in leakage current (measured under standard conditions), but the original value is usually restored within a few minutes after application of rated voltage.

Tantalum chips are not hermetically sealed, therefore they do exhibit reversible changes in parameters with respect to relative humidity (RH). Capacitance increases with increasing humidity. The limiting change, reached upon establishment

of equilibrium with the environment, is approximately -5% to +12% over the range from 25% to 95% RH, referred to the standard 50% RH. The amount of change is dependent upon size (capacitance and voltage rating, ie: CV product); small sizes might change no more than ±5%. Equilibrium at such extremes is seldom attained by plastic-cased capacitors, and the change in capacitance is consequently less. The rate of response to humidity changes increases with increasing temperature. Dissipation factor and ESR also increase with increasing RH.

DC leakage current may rise upon exposure to a combination of high temperature and high humidity, but is normally restored by voltage conditioning under standard conditions. The increase will be greater than that experienced under temperature influence alone because of conduction through absorbed water.

Tantalum chips may be affected by absorption of water on external insulating surfaces. The water film may also attract a layer of dust from the air, increasing the effect. The most sensitive parameter is leakage current.

4. Capacitance

- 0.1 μF to 1000 μF

Refer to part number tables for available capacitance ratings and tolerances by series.

Capacitance is measured at 120 Hz, up to 1.0 volt rms maximum and up to 2.5 volts DC maximum, at +25°C. DC bias causes only a small reduction in capacitance, up to about 2% when full rated voltage is applied. DC bias is not commonly used at room temperature, but is more commonly used at elevated temperatures. Capacitance decreases with increasing frequency.

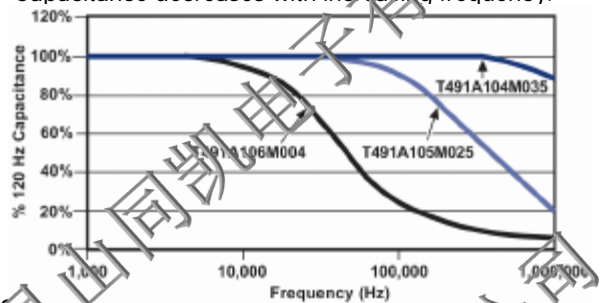

FIGURE 1

Capacitance increases with increasing temperature.

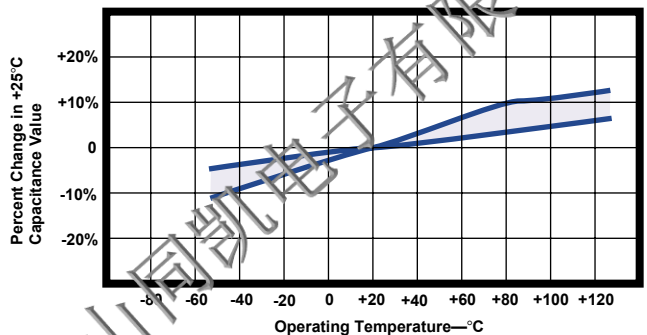

FIGURE 2 Typical Effect of Temperature upon Capacitance

TANTALUM MnO₂ COMPONENT PERFORMANCE CHARACTERISTICS (con't.)

TABLE 1 Maximum Capacitance Change with Temperature (ref: 25 °C)

Ambient Temperature		
-55°C	+85°C	+125°C
-10%	+10%	*+12% or +15%to20%

*+12% is standard. +15% and 20% apply to certain extended CV values as noted in part number tables.

5. Working DC Voltage (WVDC)

• 3 to 50 volts

Refer to part number tables for available voltage ratings by series.

These voltages are the maximum recommended peak DC operating voltages from -55°C to +85°C for continuous duty. These voltages are derated linearly above +85°C to 2/3 rated voltage for operation at +125°C (See Figure 3). For added reliability it is recommended to operate at a 50% derating of the working voltage for tantalum capacitors with MnO₂ as a cathode.

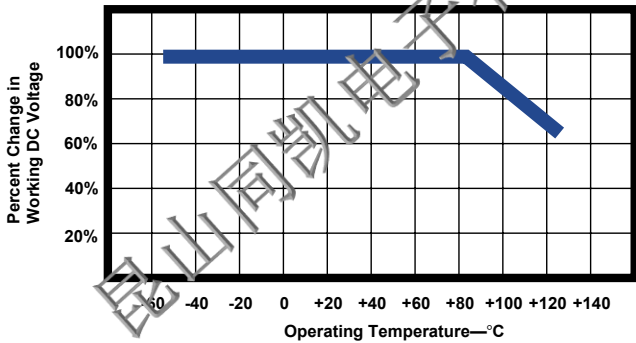

FIGURE 3 Working DC Voltage Change with Temperature

6. Surge Voltage

TABLE 2 Surge Voltage Ratings at +25°C, +85°C & +125°C

Rated Working Volts @ +25°C & +85°C	Surge Voltage @ +25°C & +85°C	Derated DC Volts @ +125°C	Surge Voltage @ +125°C
3	4	2	2.4
4	5.2	2.7	3.2
6	8	4	5
10	13	7	8
16	20	10	12
20	26	13	16
25	33	17	20
35	46	23	28
50	65	33	40

Surge voltage is the maximum voltage to which the capacitor can be subjected under transient

conditions, including the sum of peak AC ripple, DC bias and any transients.

Surge voltage tests are performed at +25°C, +85°C and +125°C with the applicable surge voltage. The surge voltage is applied for 1000 cycles of 30 seconds at voltage through a 33 ohm series resistor and 30 seconds off voltage with the capacitor discharged through a 33 ohm resistor. Upon completing the test, the capacitors are allowed to stabilize at room temperature. Capacitance, DCL and DF are then tested:

- Capacitance — within ± 5% of initial value
- DC Leakage — within initial limit
- Dissipation Factor — within initial limit
- ESR — within initial limit

7. Reverse Voltage and Polarity

TABLE 3 Reverse Voltage Ratings

Temperature	Permissible Reverse Voltage
+25°C	15% of Rated Voltage
+85°C	5% of Rated Voltage
+125°C	1% of Rated Voltage

Solid tantalum capacitors are polarized devices and may be permanently damaged or destroyed if connected with the wrong polarity. The positive terminal is identified on the capacitor body by a stripe and a beveled edge. A small degree of transient reverse voltage is permissible for short periods per Table 3. The capacitors should not be operated continuously in reverse mode, even within these limits.

8. DC Leakage Current (DCL)

Refer to part number tables for maximum leakage current limits.

DC leakage current is the current that, after a one-to five-minute charging period, flows through a capacitor when voltage is applied. Leakage is measured at +25°C with full rated DC voltage applied to the capacitor through a 1000 ohm resistor in series with the capacitor.

DC leakage current increases with increasing temperature.

TABLE 4 Leakage Limit Multipliers at Specified Temperatures (ref: 25 °C limits)

Ambient Temperature		
-55°C	+85°C	+125°C
N/A	10X	12X

TANTALUM MnO₂ COMPONENT PERFORMANCE CHARACTERISTICS (con't.)

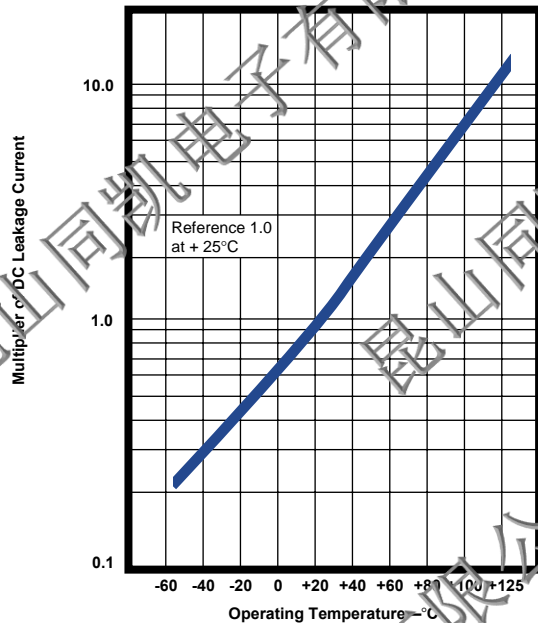

FIGURE 4 Typical Effect of Temperature upon DC Leakage Current

DC leakage current decreases with decreasing applied voltage.

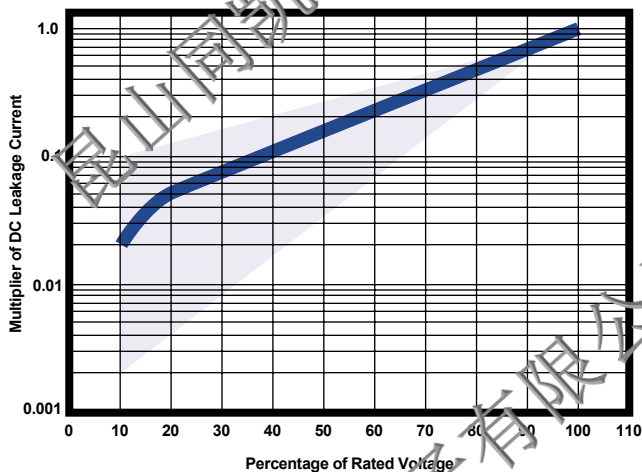

FIGURE 5 Typical Effect of Applied Voltage on DC Leakage Current.

9. Dissipation Factor (DF)

Refer to part number tables for maximum DF limits.

Dissipation factor is measured at 120 Hz, up to 1.0 volt rms maximum, and up to 2.0 volts DC maximum, at +25°C. The application of DC bias causes a small reduction in DF, about 0.2% when full rated voltage is applied. DF increases with increasing frequency.

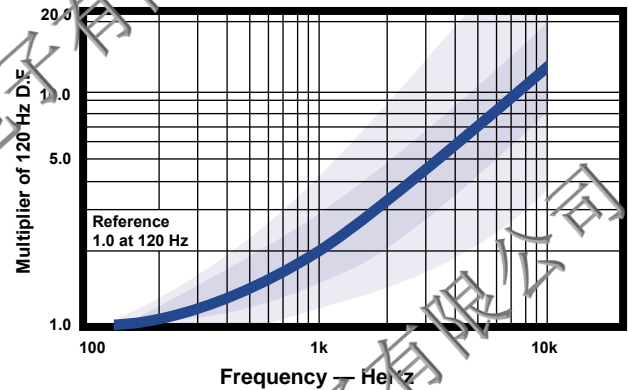

FIGURE 6 Typical Effect of Frequency upon Dissipation Factor

Dissipation factor is a very useful low frequency (120 Hz) measurement of the resistive component of a capacitor. It is the ratio of the equivalent series resistance (ESR) to the capacitive reactance, (X_c) and is usually expressed as a percentage. It is directly proportional to both capacitance and frequency. Dissipation factor loses its importance at higher frequencies, (above about 1 kHz), where impedance (Z) and equivalent series resistance (ESR) are the normal parameters of concern.

$$DF = \frac{R}{X_c} = 2\pi fCR$$

DF = Dissipation Factor

R = Equivalent Series Resistance (Ohms)

X_c = Capacitive Reactance (Ohms)

f = Frequency (Hertz)

C = Series Capacitance (Farads)

DF is also referred to as $\tan \delta$ or "loss tangent." The "Quality Factor" "Q," is the reciprocal of DF.

DF decreases with temperature above +25°C and may also increase at lower temperatures. Unfortunately, one general limit for DF cannot be specified for all capacitance/voltage combinations, nor can response to temperature be simply stated. DC bias is not commonly used at room temperature, but is more commonly used at elevated temperatures.

10. Equivalent Series Resistance (ESR) and Impedance (Z)

Equivalent Series Resistance (ESR) is the preferred high-frequency statement of the resistance unavoidably appearing in these capacitors. ESR is not a pure resistance, and it decreases with increasing frequency.

Total impedance of the capacitor is the vector sum of capacitive reactance (X_c) and ESR, below resonance; above resonance total impedance is the vector sum of inductive reactance (X_L) and ESR.

TANTALUM MnO₂ COMPONENT PERFORMANCE CHARACTERISTICS (con't.)

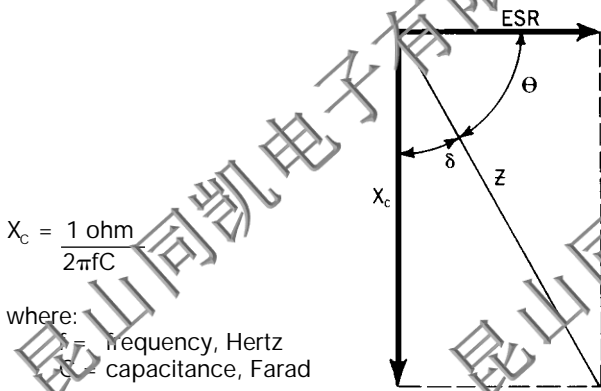

FIGURE 7a Total Impedance of the Capacitor Below Resonance

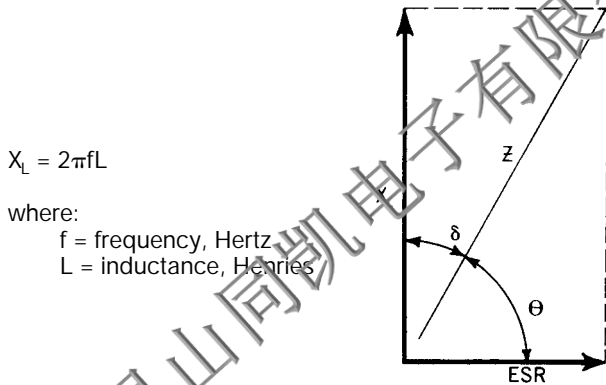

FIGURE 7b Total Impedance of the Capacitor Above Resonance

To understand the many elements of a capacitor, see Figure 8.

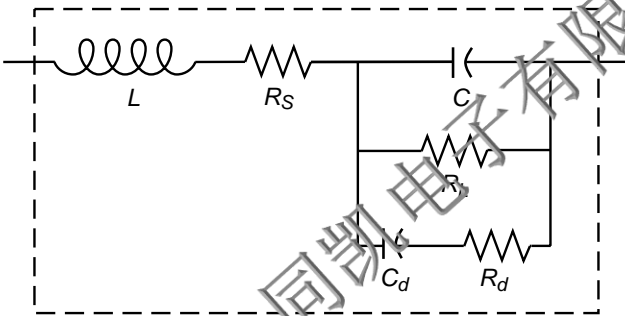

FIGURE 8 The Real Capacitor

A capacitor is a complex impedance consisting of many series and parallel elements, each adding to the complexity of the measurement system.

L — Represents lead wire and construction inductance. In most instances (especially in solid tantalum and monolithic ceramic capacitors) it is insignificant at the basic measurement frequencies of 120 and 1000 Hz.

R_s — Represents the actual ohmic series resistance in series with the capacitance. Lead wires and capacitor electrodes are contributing sources.

R_l — Capacitor Leakage Resistance. Typically it can reach 50,000 megohms in a tantalum capacitor. It can exceed 10^{12} ohms in monolithic ceramics and in film capacitors.

R_d — The dielectric loss contributed by dielectric absorption and molecular polarization. It becomes very significant in high frequency measurements and applications. Its value varies with frequency.

C_d — The inherent dielectric absorption of the solid tantalum capacitor which typically equates to 1-2% of the applied voltage.

As frequency increases, X_c continues to decrease according to its equation above. There is unavoidable inductance as well as resistance in all capacitors, and at some point in frequency, the reactance ceases to be capacitive and becomes inductive. This frequency is called the self-resonant point. In solid tantalum capacitors, the resonance is damped by the ESR, and a smooth, rather than abrupt, transition from capacitive to inductive reactance follows.

Typical ESR/Z frequency response curves are shown in Figures 9a and 9b. These curves are for selected ratings and represent typical T491 Series performance. Maximum limits for 100 kHz ESR are listed in the part number tables for each series. Note that the T494 Series offers low ESR and the T495 Series is specially designed for very low ESR performance. Refer to pages 27 and 31 for more information. See also KEMET's T510 Series low ESR ratings on page 37.

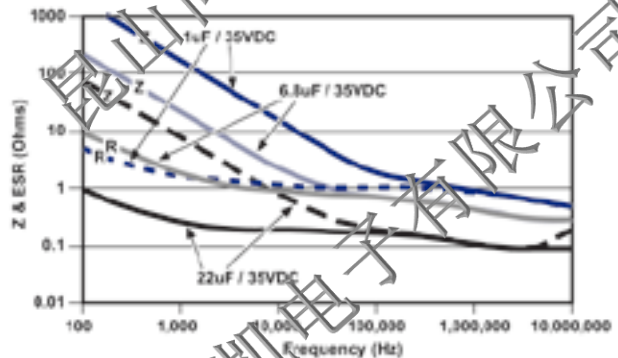

FIGURE 9a ESR & Impedance (Z) vs Frequency

TANTALUM MnO₂ COMPONENT PERFORMANCE CHARACTERISTICS (con't.)

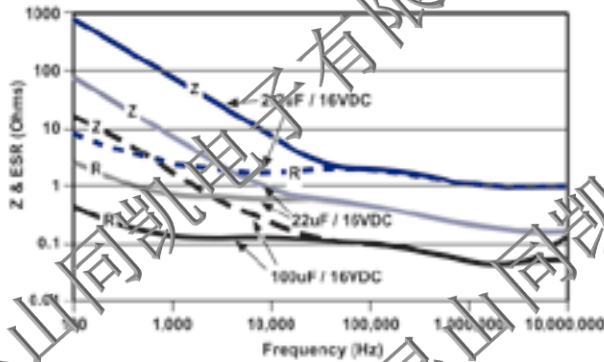

FIGURE 9b ESR & Impedance (z) vs Frequency

ESR and Z are also affected by temperature. At 100 kHz, ESR decreases with increasing temperature. The amount of change is influenced by the size of the capacitor and is generally more pronounced on smaller ratings.

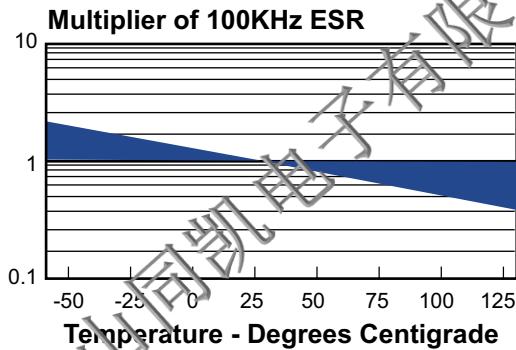

FIGURE 10 Typical Effect of Temperature on 100 kHz ESR

11. AC Power Dissipation

Power dissipation is a function of capacitor size and materials. Maximum power ratings have been established for all case sizes to prevent overheating. In actual use, the capacitor's ability to dissipate the heat generated at any given power level may be affected by a variety of circuit factors. These include board density, pad size, heat sinks and air circulation.

TABLE 5 Tantalum Chip Power Dissipation Ratings

Case Code		Maximum Power Dissipation mW @ +25°C w/+20°C Rise
KEMET	EIA	
R	2012-12	25
S	3216-12	60
T	3528-12	70
U	5032-15	90
V	7343-20	125
A	3216-18	75
E	3528-21	85
C	3062-28	110
D	7343-31	150
X	7343-43	165
E	7260-38	200
T530D	7343-31	255
T510X, T530X	7343-43	270
T510E, T530E	7260-38	285

12. AC Operation

Permissible AC ripple voltage and current are related to equivalent series resistance (ESR) and power dissipation capability.

Permissible AC ripple voltage which may be applied is limited by three criteria:

- The positive peak AC voltage plus the DC bias voltage, if any, must not exceed the DC voltage rating of the capacitor.
- The negative peak AC voltage, in combination with the bias voltage, if any, must not exceed the permissible reverse voltage ratings presented in Table 3.
- The power dissipated in the ESR of the capacitor must not exceed the appropriate value specified in Table 5.

Actual power dissipated may be calculated from the following:

$$P = I^2 R$$

$$\text{Substituting } I = \frac{E}{Z}, \quad P = \frac{E^2 R}{Z^2}$$

where:

I = rms ripple current (amperes)

E = rms ripple voltage (volts)

P = power (watts)

Z = impedance at specified frequency (ohms)

R = equivalent series resistance at specified frequency (ohms)

Using P max from Table 5, maximum allowable rms ripple current or voltage may be determined as follows:

$$I (\text{max}) = \sqrt{P \text{ max}} / R, \quad E (\text{max}) = Z \sqrt{P \text{ max}} / R$$

These values should be derated at elevated temperatures as follows:

Temperature	Derating Factor
85°C	.9
125°C	.4

ENVIRONMENTAL

13. Temperature Stability

TABLE 6 Temperature Stability Limits

Step No.	Temp.	Δ Capacitance	Leakage Current	Dissipation Factor
1	+25°C	within specified tolerance	within original limit	within original limit
2	-55°C	within ± 10% of initial value	N/A	within original limit**
3	+25°C	within ± 5% of initial value	within original limit	within original limit**
4	+ 85°C	within ± 10% of initial value	within 10X original limit	within original limit***
5	+125°C	*within ± 12% or 20% of initial value	within 12X original limit	within original limit***
6	+25°C	within ± 5% of initial value	within original limit	within original limit

*+12% is standard. +15% or +20% applies to certain CV values as noted in part number table.

**within 1.5x initial limit for extended CV values.

***within 1.15x initial limit for extended CV values.

TANTALUM MnO₂ COMPONENT PERFORMANCE CHARACTERISTICS (con't.)

Mounted capacitors withstand extreme temperature testing at a succession of continuous steps at +25°C, -55°C, +25°C, +85°C, +125°C, +25°C, in the order stated. Capacitors shall be brought to thermal stability at each test temperature. Capacitance, DF and DCL are measured at each test temperature except that DCL is not measured at -55°C. DC bias of 2.0 ± 0.5 is recommended for the capacitance and DF requirements.

14. Thermal Shock

- *Mil-Std-202, Method 107, Condition B*

Minimum temperature -55°C, mounted

Post Test Performance:

- Capacitance — within ±5% of initial value
- DC Leakage — within initial limit
- Dissipation Factor — within initial limit
- ESR — within initial limit

15. Moisture Resistance

- *Mil-Std-202, Method 106*

Steps 7a and 7b excluded, rated voltage, 42 cycles, mounted

Post Test Performance:

- Capacitance — within ±10% of initial value
- DC Leakage — within initial limit
- Dissipation Factor — within initial limit
- ESR — within initial limit

16. Electrostatic Discharge (ESD)

- *Human Body Model*
2,000 ±50 volts, 1,500 ±5% ohms, 40 nanosecond pulse each polarity, 1 pulse each polarity, 5 seconds between pulses, +25°C.
- *Charged Device Model*
200 ± 5 volts, 0 ohms, 40 nanosecond pulse, each polarity, 9 pulses each polarity, 5 seconds between pulses, +25°C.

Product subjected to above test condition demonstrate *no sensitivity* to electrostatic discharge.

17. Long Term Stability

Within the general class of electrolytic capacitors, solid tantalum capacitors offer unusual stability of the three important parameters: capacitance, dissipation factor and leakage current. These solid-state devices are not subject to the effects of electrolysis, deforming or drying-out associated with liquid electrolyte capacitors.

When stabilized for measurement at standard conditions, capacitance will typically change less than ±3% during a 10,000 hour life test +85°C.

The same comparative change has been observed in shelf tests at +25°C extending for 50,000 hours. (Some of this change may stem from instrument or fixture error.)

Dissipation factor exhibits no typical trend. Data from 10,000 hour life test at +85°C show that initial limits (at standard conditions) are not exceeded at the conclusion of these tests.

Leakage current is more variable than capacitance or DF; in fact, leakage current typically exhibits a logarithmic dependence in several respects. Military Specifications permit leakage current (measured at standard conditions) to rise by a factor of four over 10,000 hour life tests. Typical behavior shows a lower rate of change, which may be negative or positive. Initial leakage currents are frequently so low (less than 0.1 nanoampere in the smallest CV capacitors) that changes of several orders of magnitude have no discernable effect on the usual circuit designs.

18. Failure Mode

Capacitor failure may be induced by exceeding 50% of rated voltage of the capacitor with forward DC voltage, reverse DC voltage, power dissipation, or temperature. As with any practical device, these capacitors also possess an inherent, although low, failure rate when operated at less than 50% of the rated voltage of the capacitor.

The dominant failure mode is by short-circuit. Minor parametric drifts are of no consequence in circuits suitable for solid tantalum capacitors. Catastrophic failure occurs as an avalanche in DC leakage current over a short (millisecond) time span. The failed capacitor, while called "short-circuited", may exhibit a DC resistance of 10 to 10⁴ ohm.

If a failed capacitor is in an unprotected low-impedance circuit, continued flow of current through the capacitor may obviously produce severe overheating. The over-heated capacitor may damage the circuit board or nearby components. Protection against such occurrence is obtained by current-limiting devices or fuses provided by the circuit design. KEMET's 1496 series offers a built-in fuse to convert the normal short circuit failure mode to an open circuit.

Fortunately, the inherent failure rate of KEMET solid tantalum capacitors is low, and this failure rate may be further improved by circuit design. Statistical failure rates are provided for military capacitors. Relating circuit conditions to failure rate is aided by the guides in the section following.

TANTALUM MnO₂ COMPONENT PERFORMANCE CHARACTERISTICS (con't.)

RELIABILITY

19. Reliability Prediction

Solid tantalum capacitors exhibit no degradation failure mode during shelf storage and show a constantly decreasing failure rate (i.e., absence of any wear out mechanism) during life tests. This failure rate is dependent upon three important application conditions; DC Voltage, ambient temperature, and circuit impedance. Additional effects are attributable to the capacitance of the device and atmospheric and mechanical exposure of the assembled circuit. The 1000 multiplier at the end converts the failure rate to parts-per-billion piece-hours. A prediction of the failure rate can be made using these application conditions and the formulas and tables listed in MIL-HDBK-217F (Notice 2).

Base Multiplier: The first multiplier is the base multiplier (2) established for the capacitor type. For "CWR-Chips" or surface mount components the base multiplier is 0.00005, and for "CSR-Leaded" devices, the base multiplier is 0.00040.

Temperature: The temperature factor is given as (3). From this formula, it can be seen that the unity factor, or 1, is derived at an ambient temperature of +25°C (+298 K), and that at temperatures below this the multiplier is decreasing and at temperatures above this the multiplier is increasing.

Voltage: The multiplier for application voltage (4) is a two step process: first, the application voltage is compared to 60% of rated voltage, and then this ratio is raised to an exponential power of 17 and added to unity. Consider applications of 50%, 60%, 70%, 80% and 90% of rated voltage. The multipliers for these applications would be 1.045, 2.00, 14.7, 134, and 986, respectively. From these results it is evident why manufacturers recommend application voltages not to exceed 50% rated voltages.

Capacitance: There is a factor (5) applied to the capacitance (in µF) which effectively increases the failure rate for increasing capacitance (increases in effective area resulting in increases in possible faults).

Series Resistance: The series resistance is only concerned with the resistance per application bias (ohms per volt) external to the capacitor, and does not include the ESR as a factor.

Environmental: The environmental factor is determined by the harshness of the ambient conditions beyond temperature. An explanation of these ratings is included in the MIL specification and are too extensive to be covered here. In most cases, this factor is set to ground benign or G_B, with the resulting factor equal to "1".

- (1) $\lambda_V = \lambda_b \pi_T \pi_C \pi_V \pi_{SR} \pi_Q \pi_E \times 1000$
- (2) $\lambda_b = 0.00005_{CWR} \text{ or } 0.0004_{CSR}$
- (3) $\pi_T = \exp \left[\frac{-0.15}{8.617 \cdot 10^{-5}} \left(\frac{1}{T_{Amb}} - \frac{1}{298} \right) \right]$
- (4) $S = \frac{\text{Application-Voltage}}{\text{Rated-Voltage}} \quad \pi_V = \left(\frac{S}{0.6} \right)^{17} + 1$
- (5) $\pi_C = 1.0 \cdot C^{0.23}$
- (6) $\pi_{SR} = \text{Lookup Table} \quad \pi_E = \text{Lookup Table}$
- (7) $\pi_Q = \sqrt[4]{\left(\frac{\text{Pcs. Fail}}{\text{Pcs. Tested} \times \text{Hrs. Tested}} \times 100,000 \right)}$

FIGURE 11a. MIL-HDBK-217F Notice 2 formulas.

CR (ΩV)	π _{SR}
>0.8	0.66
0.6-0.8	1.0
0.4-0.6	1.3
0.2-0.4	2.0
0.1-0.2	2.7
<0.1	3.3

FIGURE 11b. Table for circuit resistance multipliers.

Quality Factor: All of these multipliers are applied to the established or base failure rate of the part. The T492 Series is qualified under U.S. military specification MIL-PRF-55365. Failure rates as low as 0.001% kWh are available under this test program.

For series not covered by military specifications, an internal sampling program is operated by KEMET Quality Assurance whereby parts are put on life test at rated voltage for 2000 hours. The confidence level chosen for the reporting data is 60%. (The cost of sampling each batch would be prohibitive, and no claim is made to guarantee the failure rate of each batch.) With this testing and each new qualification test for new parts, the average failure rate for all commercial Series lies between 0.1% and 1.0% per thousand-piece-hours.

FIT Calculator

All of these factors are gathered into a Windows based software, available free from the KEMET web site (www.kemet.com). The "FIT Calculator" software does all the calculations and look-ups based on information entered or selected by the operator. A manual may also be downloaded from the same web page to explain the controls and displays. The manual as well as a help screen also detail the environmental conditions.

TANTALUM MnO₂ COMPONENT PERFORMANCE CHARACTERISTICS (con't.)

20. Surge Current

All conventional reliability testing is conducted under steady-state DC voltage. Experience indicates that AC ripple, within the limits prescribed, has little effect on failure rate. Heavy surge currents are possible in some applications, however. Circuit impedance may be very low (below the recommended 0.1 ohm/volt) or there may be driving inductance to cause voltage "ringing." Surge current may appear during turn-on of equipment, for example. Failure rate under current-surge conditions may not be predictable from conventional life test data.

Capacitors are capable of withstanding a 4 ±1 second charge of rated voltage (±2%) through a total circuit resistance (excluding the capacitor) of 1 ±0.2 ohms at +25°C, followed by a 4 ±1 second discharge to a voltage below 1% of the rated voltage. This cycle is repeated consecutively three (3) times. Post test performance:

- a. Capacitance — within ±5% of initial value
- b. DC Leakage — within initial limit
- c. Dissipation Factor — within initial limit

100% production surge current testing is performed on all Tantalum Chip series for case sizes C, D, E, X, U, V. The total test circuit resistance is ≤ 0.5 ohms. The applied voltage is 75% of rated voltage for all series except the T495 and T510 which are surged at 100% of rated voltage. Four surge cycles are applied. Parts not capable of surviving this test are removed at subsequent electrical screening. See T493 Series on page 22 for specific surge options.

21. Storage Life Test

- **2,000 hours, +125°C, Unbiased, Mounted**

Post Test Performance:

- a. Capacitance — within ±10% of initial value
- b. DC Leakage — within initial limit
- c. Dissipation Factor — within initial limit
- d. ESR — within initial limit
- e. Physical — no degradation of function

22. Standard Life Test

- **2,000 hours, +85°C, Rated Voltage, Mounted**

Post Test Performance:

- a. Capacitance — within ±10% of initial value
- b. DC Leakage — within 125% of initial limit
- c. Dissipation Factor — within initial limit
- d. ESR — within initial limit
- e. Physical — no degradation of function

23. High Temperature Life Test

- **2,000 hours, +125°C, 2/3 Rated Voltage, Mounted**

Post Test Performance:

- a. Capacitance — within ±10% of initial value
- b. DC Leakage — within 125% of initial limit
- c. Dissipation Factor — within initial limit
- d. ESR — within initial limit
- e. Physical — no degradation of function

MECHANICAL

24. Resistance to Solvents

- **Mil-Std-202, Method 215**

Post Test Performance:

- a. Capacitance — within ±10% of initial value
- b. DC Leakage — within initial limit
- c. Dissipation Factor — within initial limit
- d. Physical — no degradation of case, terminals or marking.

25. Fungus

- **Mil-Std-810, Method 508**

26. Flammability

- **UL94 VO Classification**

Encapsulant materials meet this classification.

27. Resistance to Soldering Heat

- **Wave Solder**
+260 ±5°C, 10 Seconds
- **Infrared Reflow**
+230 ±5°C, 30 Seconds
- **Vapor Phase Reflow**
+215 ±5°C, 2 minutes

Post Test Performance:

- a. Capacitance — within ±10% of Initial Value
- b. DC Leakage — within Initial Limit
- c. Dissipation Factor — within Initial Limit

28. Solderability

- **Mil-Std-202, Method 208**
- **ANSI/J-STD-002, Test B**

Applies to Solder and Tin Coated terminations only. Does not apply to optional gold-plated terminations.

29. Vibration

- **Mil-Std-202, Method 204, Condition D, 10 Hz to 2,000 Hz, 20G Peak**

Post Test Performance:

- a. Capacitance — within ±10% of initial value
- b. DC Leakage — within initial limit
- c. Dissipation Factor — within initial limit

30. Shock

- **Mil-Std-202, Method 213, Condition I, 100 G Peak**

Post Test Performance:

- a. Capacitance — within ±10% of initial value
- b. DC Leakage — within initial limit
- c. Dissipation Factor — within initial limit

31. Terminal Strength

- **Pull Force**
• **One Pound (454 grams), 30 Seconds**

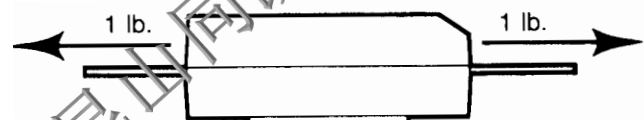

TANTALUM MnO₂ COMPONENT PERFORMANCE CHARACTERISTICS (con't.)

- **Tensile Force**
- **Four Pounds (1.8 kilograms), 60 Seconds**

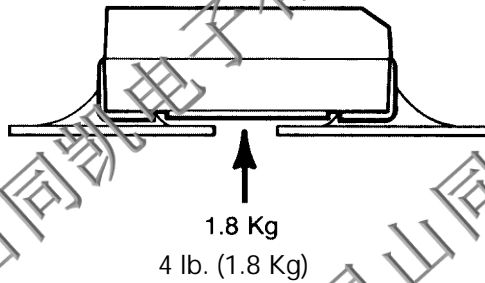

Shear Force
Table 8 Maximum Shear Loads

Case Code		Maximum Shear Loads	
KEMET	EIA	Kilograms	Pounds
R	2012-12	2.4	5.3
S	3216-12	3.2	7.0
T	3528-12	3.6	8.0
U	6032-15	4.5	10.0
V	7343-20	5.0	11.0
A	3216-18	3.2	7.0
B	3528-21	3.6	8.0
C	6032-28	4.5	10.0
D	7343-31	5.0	11.0
X	7343-43	5.0	11.0
E	7260-38	5.0	11.0

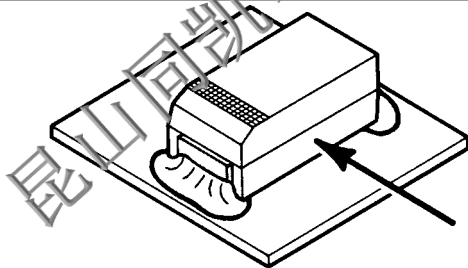

Post Test Performance:

- Capacitance — within $\pm 5\%$ of initial value
- DC Leakage — within initial limit
- Dissipation Factor — within initial limit

APPLICATIONS

32. Handling

Automatic handling of encapsulated components is enhanced by the molded case which provides compatibility with all types of high speed pick and place equipment. Manual handling of these devices presents no unique problems. Care should be taken with your fingers, however, to avoid touching the solder-coated terminations as body oils, acids and salts will degrade the solderability of these terminations. Finger cots should be used whenever manually handling all solderable surfaces.

33. Termination Coating

After May 1, 2004, the standard finish coating for all molded series is transitioning to 100% tin.

For conductive adhesive attachment processes, a

gold termination finish is available, at additional cost, on the T491, T494 and T495 Series only. The gold finish is not recommended for solder attachment.

Refer to specific lead frame options available on T493 Series. Refer to www.kemet.com for details on Pb free transition.

34. Recommended Mounting Pad Geometries

Proper mounting pad geometries are essential for successful solder connections. These dimensions are highly process sensitive and should be designed to maximize the integrity of the solder joint, and to minimize component rework due to unacceptable solder joints.

Figure 12 illustrates pad geometry. Tables 9 & 10 provide recommended pad dimensions for both wave and reflow soldering techniques. These dimensions are intended to be a starting point for circuit board designers, to be fine tuned, if necessary, based upon the peculiarities of the soldering process and/or circuit board design.

Contact KEMET for Engineering Bulletin Number F-2100 entitled "Surface Mount Mounting Pad Dimensions and Considerations" for further details on this subject.

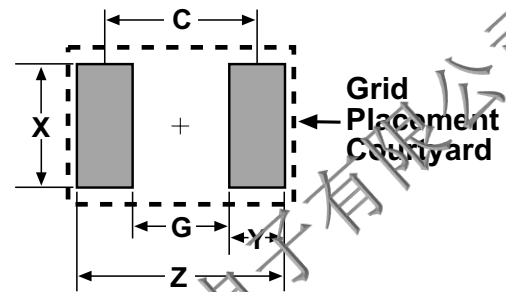

Figure 12

Table 9 – Land Pattern Dimensions for Reflow Solder

KEMET/EIA Size Code	Pad Dimensions - mm				
	Z	G	X	Y (ref)	C (ref)
R/2012-12	3.90	0.80	1.80	1.55	2.35
A/3216-18, S/3216-12	4.70	0.80	1.50	1.95	2.75
B/3528-21, T/3528-12	5.00	1.10	3.50	1.95	3.05
C/6032-28, U/6032-15	7.60	2.50	2.50	2.55	5.05
D/7343-31, V/7343-20, X/7343-43	8.90	3.80	2.70	2.55	6.35
E/7260-38	8.90	3.80	4.40	2.55	6.35

Table 10 – Land Pattern Dimensions for Wave Solder

KEMET/EIA Size Code	Pad Dimensions - mm				
	Z	G	X	Y (ref)	C (ref)
R/2012-12	4.30	0.80	1.26	1.75	2.55
A/3216-18, S/3216-12	5.10	0.80	1.10	2.15	2.95
B/3528-21, T/3528-12	5.40	1.10	1.80	2.15	3.25
C/6032-28, U/6032-15	8.00	2.50	1.80	2.75	5.25
D/7343-31, V/7343-20, X/7343-43	9.70	3.80	2.70	2.95	6.75
E/7260-38	9.70	3.80	4.40	2.95	6.75

TANTALUM MnO₂ COMPONENT PERFORMANCE CHARACTERISTICS (con't.)

35. Soldering

KEMET's families of surface mount tantalum capacitors are compatible with wave (single or dual) soldering and IR or vapor phase reflow techniques. Solder coated terminations have excellent wetting characteristics for high integrity solder fillets. Preheating of these components is recommended to avoid extreme thermal stress. The maximum recommended preheat rate is 2°C per second. Figure 13 represents recommended maximum solder temperature / time combinations for these devices.

Note that although the X/7343-43 case size can withstand wave soldering, the tall profile (4.3mm maximum) dictates care in wave process development.

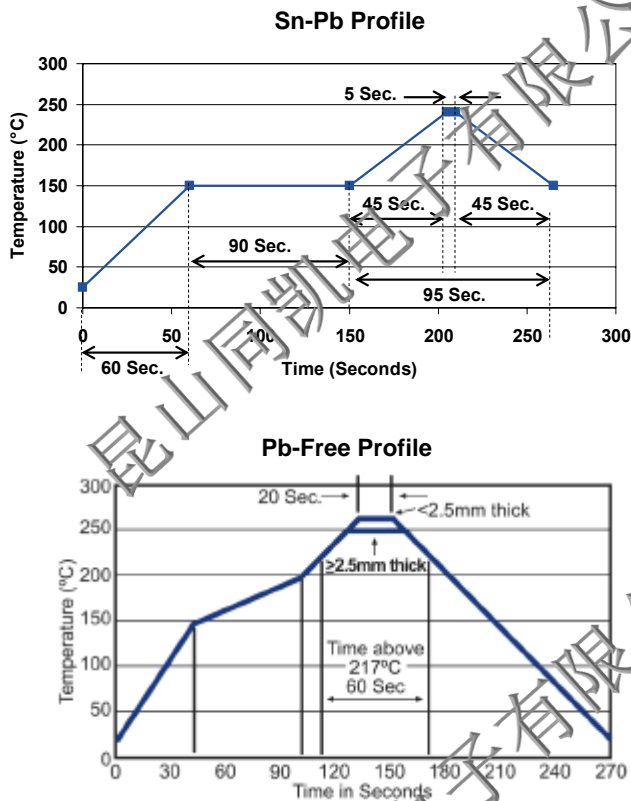

FIGURE 13 Time/Temperature Soldering Profile

Hand-soldering should be performed with care due to the difficulty in process control. If performed, care should be taken to avoid contact of the soldering iron to the molded case. The iron should be used to heat the solder pad, applying solder between the pad and the termination, until reflow occurs. The iron should be removed. "Wiping" the edges of a chip and heating the top surface is not recommended.

During typical reflow operations a slight darkening of the gold-colored epoxy may be observed. This slight darkening is normal and is not harmful to the product. Marking permanency is not affected by this change.

36. Washing

Standard washing techniques and solvents are compatible with all KEMET surface mount tantalum capacitors. Solvents such as Freon TMC and TMS, Trichlorethane, methylene chloride, prelete, and isopropyl alcohol are not harmful to these components.

If ultrasonic agitation is utilized in the cleaning process, care should be taken to minimize energy levels and exposure times to avoid damage to the terminations.

KEMET tantalum chips are also compatible with newer aqueous and semi-aqueous processes. Please follow the recommendations for cleaning as defined by the solder vendor.

37. Encapsulations

Under normal circumstances, potting or encapsulation of KEMET tantalum chips is not required.

38. Storage Environment

Tantalum chip capacitors should be stored in normal working environments. While the chips themselves are quite robust in other environments, solderability will be degraded by exposure to high temperatures, high humidity, corrosive atmospheres, and long term storage. In addition, packaging materials will be degraded by high temperature - reels may soften or warp, and tape peel force may increase. KEMET recommends that maximum storage temperature not exceed 40 degrees C, and maximum storage humidity not exceed 60% relative humidity. In addition, temperature fluctuations should be minimized to avoid condensation on the parts, and atmospheres should be free of chlorine and sulfur bearing compounds. For optimized solderability, chip stock should be used promptly, preferably within 3 years of receipt.

SOLID TANTALUM CHIP CAPACITORS

T491 SERIES - Precision Molded Chip



FEATURES

- Meets or Exceeds EIA Standard 35BAAC
- Taped and Reeled per EIA 481-1
- Symmetrical, Compliant Terminations
- Optional Gold-plated Terminations
- Laser-marked Case
- 100% Surge current test on C, D, E, U, V, X sizes
- Halogen Free Epoxy
- Capacitance: 0.1 μ F to 1000 μ F
- Tolerance: $\pm 10\%$, $\pm 20\%$
- Voltage: 5 to 50 VDC
- Extended Range Values
- Low Profile Case Sizes
- RoHS Compliance
- Lead Free Terminations (See www.kemet.com for transition information)

CAPACITOR OUTLINE DRAWING

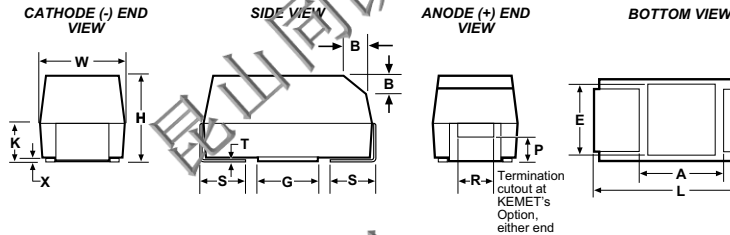

STANDARD T491 DIMENSIONS

Millimeters (inches)

CASE SIZE	KEMET	EIA	COMPONENT													
			L*	W*	H*	F ± 0.20 $\pm (.008)$	S ± 0.1 $\pm (.004)$	G ± 0.3 $\pm (.012)$	B ± 0.15 $\pm (.006)$	X (Ref)	P (Ref)	R (Ref)	T (Ref)	A (Min)	G (Ref)	E (Ref)
A	3216-18		3.2 \pm 0.2 (.126 \pm .008)	1.6 \pm 0.2 (.063 \pm .008)	1.0 \pm 0.2 (.039 \pm .008)	0.9 (.035)	1.2 (.047)	0.8 (.031)	0.4 (.016)	0.10 \pm 0.10 (.004 \pm .004)	0.4 (.016)	0.4 (.016)	0.13 (.005)	0.8 (.031)	1.1 (.043)	1.3 (.051)
B	3528-21		3.5 \pm 0.2 (.138 \pm .008)	2.5 \pm 0.2 (.110 \pm .008)	1.9 \pm 0.2 (.075 \pm .008)	1.1 (.043)	2.2 (.087)	0.8 (.031)	0.4 (.016)	0.10 \pm 0.10 (.004 \pm .004)	0.5 (.020)	1.0 (.039)	0.13 (.005)	1.1 (.043)	1.8 (.071)	2.2 (.087)
C	6032-28		6.0 \pm 0.3 (.236 \pm .012)	3.2 \pm 0.3 (.126 \pm .012)	2.5 \pm 0.3 (.098 \pm .012)	1.4 (.055)	2.2 (.087)	1.3 (.051)	0.5 (.020)	0.10 \pm 0.10 (.004 \pm .004)	0.9 (.035)	1.0 (.039)	0.13 (.005)	2.5 (.098)	2.8 (.110)	2.4 (.094)
D	7343-31		7.3 \pm 0.3 (.287 \pm .012)	4.0 \pm 0.3 (.169 \pm .012)	2.8 \pm 0.3 (.110 \pm .012)	1.5 (.059)	2.4 (.094)	1.3 (.051)	0.5 (.020)	0.10 \pm 0.10 (.004 \pm .004)	0.9 (.035)	1.0 (.039)	0.13 (.005)	3.8 (.150)	3.5 (.138)	3.5 (.138)
X	7343-48		7.3 \pm 0.3 (.287 \pm .012)	4.3 \pm 0.3 (.169 \pm .012)	4.0 \pm 0.3 (.157 \pm .012)	2.3 (.091)	2.4 (.094)	1.3 (.051)	0.5 (.020)	0.10 \pm 0.10 (.004 \pm .004)	1.7 (.067)	1.0 (.039)	0.13 (.005)	3.8 (.150)	3.5** (.138)	3.5** (.138)
E	7260-38		7.3 \pm 0.3 (.287 \pm .012)	6.0 \pm 0.3 (.236 \pm .012)	3.6 \pm 0.2 (.142 \pm .008)	2.3 (.091)	4.1 (.161)	1.3 (.051)	0.5 (.020)	0.10 \pm 0.10 (.004 \pm .004)	0.9 (.035)	1.0 (.039)	0.13 (.005)	3.8 (.150)	3.5 (.138)	3.5 (.138)

- Notes: 1. Metric dimensions govern.
 2. (Ref) - Dimensions provided for reference only.
 * Mil-C-55365/8 Specified Dimensions
 ** Round Glue Pad: 2.9 \pm 0.1mm (0.114" \pm 0.004") in diameter at KEMET's option

LOW PROFILE T491 DIMENSIONS

Millimeters (inches)

CASE SIZE	KEMET	EIA	COMPONENT										
			L	W	H Max.	K Min.	F ± 0.1	S ± 0.3	X (Ref)	T (Ref)	A (Min)	G (Ref)	E (Ref)
R	2012-12		2.0 \pm 0.2 (.079 \pm .008)	1.3 \pm 0.2 (.051 \pm .008)	1.2 (.047)	0.3 (.012)	0.9 (.035)	0.5 (.020)	0.05 (.002)	0.13 (.005)	0.8 (.031)	0.5 (.020)	0.8 (.031)
S	3216-12		3.2 \pm 0.2 (.126 \pm .008)	1.6 \pm 0.2 (.063 \pm .008)	1.2 (.047)	0.3 (.012)	1.2 (.047)	0.8 (.031)	0.05 (.002)	0.13 (.005)	0.8 (.031)	1.1 (.043)	1.3 (.051)
T	3528-12		3.5 \pm 0.2 (.138 \pm .008)	2.5 \pm 0.2 (.110 \pm .008)	1.2 (.047)	0.3 (.012)	2.2 (.087)	0.8 (.031)	0.05 (.002)	0.13 (.005)	1.1 (.043)	1.8 (.071)	2.2 (.087)
U	6032-15		6.0 \pm 0.3 (.236 \pm .012)	3.2 \pm 0.3 (.126 \pm .012)	1.5 (.059)	0.5 (.020)	2.2 (.087)	1.3 (.051)	0.05 (.002)	0.13 (.005)	2.5 (.098)	2.8 (.110)	2.4 (.094)
V	7343-20		7.3 \pm 0.3 (.287 \pm .012)	4.3 \pm 0.3 (.169 \pm .012)	2.0 (.079)	0.9 (.035)	2.4 (.094)	1.3 (.051)	0.05 (.002)	0.13 (.005)	3.8 (.150)	3.5 (.138)	3.5 (.138)

- Notes: 1. Metric dimensions govern.
 2. (Ref) - Dimensions provided for reference only.
 3. No dimensions provided for B, P or R because low profile cases do not have a bevel or a notch.

T491 ORDERING INFORMATION

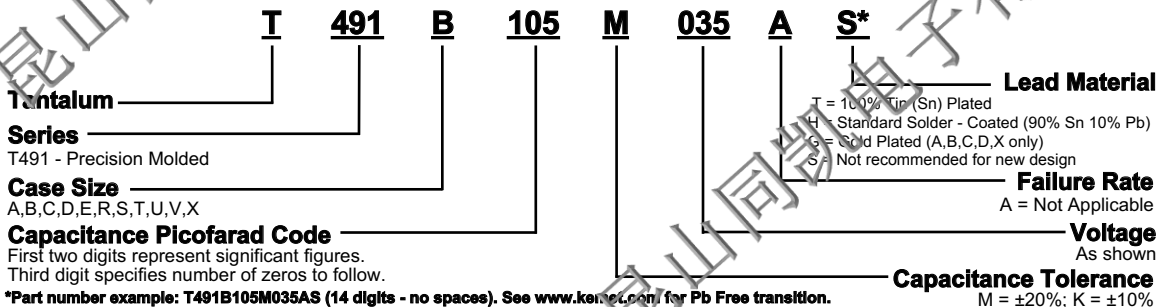



SOLID TANTALUM CHIP CAPACITORS

T491 SERIES Precision Molded Chip

T491 TANTALUM CHIP CAPACITANCE VALUES Case Size by Capacitance and Voltage

Capacitance		Rated Voltage @ +85°C									
µF	Code	2.5	3	4	6	10	16	20	25	35	50
0.10	104									A	A
0.15	154									A	A/B
0.22	224									A	B
0.33	334								A	A	B
0.47	474								A	A/B	B/C
0.68	684							A	A	A/B	B/C
1.0	105						A	R/S/A	A/B	A/B	V/C
1.5	155					A	A	S/A	A/B	B/C	C/D
2.2	225				R/A	A/B	R/S/A	A/B	B/C	B/C	C/D
3.3	335			A	A	R/S/A	A/B	T/A/B	B/C	B/C	D
4.7	475			A	S/A	A/B R/S	A/B/T	A/B/C	B/C	C/D	D
6.8	685			S/A	R/S A/B	S/T A/B	A/B/C	U/B/C	B/C	C/D	D/X
10.0	106			R/S A/B	R/S/T A/B	S/T/A B/C	B/C/U T/A	U/B/C	C/D	V/C/D	D/X
15.0	156			S/T A/B	S/T A/B/C	T/U A/B/C	U/B/C	C/D	C/D	D/X	X
22.0	226			S/T A/B/C	U/T A/B/C	T/U A/B/C	U/B C/D	V/C/D	V/C/D	D/X	
33.0	336		A	T/U A/B/C	T/U A/B/C	U/V B/C/D	U/C/D	V/C/D	D/X	X	
47.0	476			T/U A/B/C	T/U/A B/C/D	U/V B/C/D	V/C/D	D	D/X	X/E	
68.0	686			U/A B/C/D	U/A/B C/D	U/V B/C/D	V/D	D/X	X		
100.0	107	T		T/U/A B/C/D	U/V B/C/D	V/C/D	V/D/X	X			
150.0	157			V/B C/D	V/C/D	V/C D/X	D/X				
220.0	227			V	V/C D/X	V/D/X	X				
330.0	337			V/C/D	D/X	D/X					
470.0	477			D/X	D/X	X/E					
680.0	687			D/X	E						
1000.0	108			X/E							

SOLID TANTALUM CHIP CAPACITORS

T491 SERIES - Precision Molded Chip



T491 RATINGS & PART NUMBER REFERENCE

Capacitance µF	Case Size	KEMET Part Number	DC Leakage µA @ 25°C Max	DF % @ +25°C 120 Hz Max	ESR W @ +25°C 100 kHz Max
2.5 Volt Rating at +85°C (1.7 Volt Rating at +125°C)					
100.0	T	T491T107(1)2R5A(2)	2.5	24.0	3.9
3 Volt Rating at +85°C (2 Volt Rating at +125°C)					
#33.0	*A	T491A336(1)003A(2)	1.0	6.0	4.0
4 Volt Rating at +85°C (2.7 Volt Rating at +125°C)					
3.3	A	T491A33(1)004A(2)	0.5	6.0	8.0
4.7	A	T491A47S(1)004A(2)	0.5	6.0	8.0
6.8	A	T491A68S(1)004A(2)	0.5	6.0	6.0
6.8	S	T491S68S(1)004A(2)	0.5	6.0	15.0
10.0	B	T491B106(1)004A(2)	0.5	6.0	3.5
10.0	R	T491R106(1)004A(2)	0.5	6.0	6.0
#10.0	C	T491C106(1)004A(2)	0.5	6.0	15.0
#10.0	R	T491R106M004A(2)	0.5	8.0	10.0
15.0	B	T491B156(1)004A(2)	0.6	6.0	3.5
15.0	A	T491A156(1)004A(2)	0.6	6.0	4.0
15.0	T	T491T156(1)004A(2)	0.6	6.0	5.0
#15.0	*S	T491S156M004A(2)	0.6	10.0	15.0
22.0	C	T491C226(1)004A(2)	0.9	6.0	1.8
22.0	B	T491B226(1)004A(2)	0.9	6.0	3.5
#22.0	A	T491A226(1)004A(2)	0.9	6.0	4.0
#22.0	*T	T491T226(1)004A(2)	0.9	6.0	5.0
22.0	*S	T491S226M004A(2)	0.9	10.0	10.0
33.0	C	T491C336(1)004A(2)	1.3	6.0	1.8
33.0	U	T491U336(1)004A(2)	1.3	6.0	1.8
33.0	B	T491B336(1)004A(2)	1.3	6.0	3.5
#33.0	A	T491A336(1)004A(2)	1.3	6.0	4.0
#33.0	*T	T491T336M004A(2)	1.3	8.0	5.0
47.0	C	T491C476(1)004A(2)	1.9	6.0	1.8
47.0	U	T491U476(1)004A(2)	1.9	6.0	1.8
#47.0	B	T491B476(1)004A(2)	1.9	6.0	3.0
#47.0	A	T491A476M004A(2)	1.9	12.0	2.5
#47.0	*T	T491T476M004A(2)	1.9	12.0	6.0
68.0	D	T491D686(1)004A(2)	2.7	6.0	0.8
68.0	C	T491C686(1)004A(2)	2.7	6.0	1.6
#68.0	*U	T491U686(1)004A(2)	2.7	6.0	1.8
#68.0	B	T491B686(1)004A(2)	2.7	6.0	3.5
#68.0	*A	T491A686(1)004A(2)	2.8	30.0	4.0
100.0	D	T491D107(1)004A(2)	4.0	8.0	0.8
#100.0	C	T491C107(1)004A(2)	4.0	8.0	1.2
#100.0	U	T491U107(1)004A(2)	4.0	10.0	1.8
#100.0	*B	T491B107M004A(2)	4.0	8.0	1.0
†100.0	*A	T491A107(1)004A(2)	4.0	30.0	4.0
†100.0	*T	T491T107M004A(2)	4.0	30.0	5.0
150.0	D	T491D157(1)004A(2)	6.0	8.0	0.8
150.0	V	T491V157(1)004A(2)	6.0	8.0	0.7
#150.0	*C	T491C157(1)004A(2)	6.0	8.0	1.2
†150.0	*B	T491B157M004A(2)	6.0	12.0	2.0
#220.0	*V	T491V227(1)004A(2)	8.8	8.0	0.7
330.0	D	T491D337(1)004A(2)	13.2	8.0	0.7
†330.0	V	T491V337(1)004A(2)	13.2	12.0	0.7
#330.0	*C	T491C337(1)004A(2)	13.2	10.0	1.2
#470.0	*X	T491X477(1)004A(2)	18.8	8.0	0.5
#470.0	*D	T491D477(1)004A(2)	18.8	8.0	0.8
#680.0	*X	T491X687M004A(2)	27.2	12.0	0.5
#680.0	*D	T491D687M004A(2)	27.2	12.0	0.5
#1000.0	*X	T491X108(1)004A(2)	40.0	12.0	0.5
#1000.0	*E	T491E108M004A(2)	40.0	15.0	0.2
**6 Volt Rating at +85°C (4 Volt Rating at +125°C)					
2.2	R	T491R225(1)006A(2)	0.5	6.0	25.0
2.2	A	T491A225(1)006A(2)	0.5	6.0	8.0
3.3	A	T491A335(1)006A(2)	0.5	6.0	8.0
4.7	A	T491A475(1)006A(2)	0.5	6.0	6.0
4.7	S	T491S475(1)006A(2)	0.5	6.0	15.0
6.8	B	T491B685(1)006A(2)	0.5	6.0	6.0
6.8	A	T491A685(1)006A(2)	0.5	6.0	6.0
#6.8	S	T491S685(1)006A(2)	0.5	6.0	6.0
#6.8	*R	T491R685(1)006A(2)	0.5	6.0	15.0
10.0	B	T491B106(1)006A(2)	0.6	6.0	3.5
10.0	A	T491A106(1)006A(2)	0.6	6.0	4.0
10.0	T	T491T106(1)006A(2)	0.6	6.0	5.0
#10.0	*S	T491S106M006A(2)	0.6	10.0	15.0
#10.0	*R	T491R106(1)006A(2)	0.6	8.0	10.0

Capacitance µF	Case Size	KEMET Part Number	DC Leakage µA @ 25°C Max	DF % @ +25°C 120 Hz Max	ESR Ω @ +25°C 100 kHz Max
**6 Volt Rating at +85°C (4 Volt Rating at +125°C)					
15.0	C	T491C156(1)006A(2)	0.9	6.0	1.8
15.0	B	T491B156(1)006A(2)	0.9	6.0	3.5
#15.0	A	T491A156(1)006A(2)	0.9	6.0	3.5
#15.0	T	T491T156(1)006A(2)	0.9	6.0	5.0
#15.0	S	T491S156M006A(2)	0.9	15.0	10.0
22.0	C	T491C226(1)006A(2)	1.4	6.0	1.8
22.0	U	T491U226(1)006A(2)	1.4	6.0	1.8
22.0	B	T491B226(1)006A(2)	1.4	6.0	3.5
#22.0	A	T491A226(1)006A(2)	1.4	6.0	4.0
#22.0	T	T491T226M006A(2)	1.4	8.0	5.0
33.0	C	T491C336(1)006A(2)	2.0	6.0	1.8
33.0	U	T491U336(1)006A(2)	2.0	6.0	1.8
#33.0	B	T491B336(1)006A(2)	2.0	6.0	3.0
#33.0	A	T491A336(1)006A(2)	2.0	12.0	2.5
#33.0	*T	T491T336M006A(2)	2.0	12.0	6.0
47.0	D	T491D476(1)006A(2)	2.9	6.0	0.8
47.0	C	T491C476(1)006A(2)	2.9	6.0	1.6
#47.0	U	T491U476(1)006A(2)	2.9	6.0	1.8
#47.0	B	T491B476(1)006A(2)	2.9	6.0	2.0
†47.0	*A	T491A476M006A(2)	3.0	12.0	3.5
*47.0	*T	T491T476(1)006A(2)	3.0	24.0	4.4
68.0	D	T491D686(1)006A(2)	4.1	6.0	0.8
#68.0	C	T491C686(1)006A(2)	4.1	6.0	1.2
#68.0	*U	T491U686(1)006A(2)	4.1	10.0	1.8
#68.0	*B	T491B686(1)006A(2)	4.1	8.0	0.9
#68.0	*A	T491A686(1)006A(2)	5.0	30.0	4.0
100.0	D	T491D107(1)006A(2)	6.0	8.0	0.8
100.0	V	T491V107(1)006A(2)	6.0	8.0	0.7
#100.0	C	T491C107(1)006A(2)	6.0	8.0	0.9
#100.0	*U	T491U107M006A(2)	6.0	10.0	1.8
#100.0	*B	T491B107M006A(2)	6.3	15.0	3.0
150.0	D	T491D157(1)006A(2)	9.0	8.0	0.7
#150.0	*C	T491C157(1)006A(2)	9.0	8.0	1.2
#150.0	*V	T491V157(1)006A(2)	9.0	8.0	0.7
220.0	*X	T491X227(1)006A(2)	13.2	8.0	0.7
#220.0	D	T491D227(1)006A(2)	13.2	8.0	0.7
#220.0	C	T491C227M006A(2)	13.2	10.0	1.2
#220.0	*V	T491V227M006A(2)	13.2	12.0	0.7
330.0	*X	T491X337(1)006A(2)	19.8	8.0	0.4
330.0	*D	T491D337(1)006A(2)	19.8	8.0	0.4
470.0	*X	T491X477(1)006A(2)	28.2	10.0	0.4
470.0	*D	T491D477M006A(2)	28.2	12.0	0.4
680.0	*E	T491E687M006A(2)	40.8	12.0	0.5
10 Volt Rating at +85°C (7 Volt Rating at +125°C)					
1.5	A	T491A155(1)010A(2)	0.5	6.0	8.0
2.2	B	T491B225(1)010A(2)	0.5	6.0	3.5
2.2	A	T491A225(1)010A(2)	0.5	6.0	8.0
3.3	A	T491A335(1)010A(2)	0.5	6.0	6.0
3.3	S	T491S335(1)010A(2)	0.5	6.0	15.0
#3.3	*R	T491R335(1)010A(2)	0.3	8.0	15.0
4.7	B	T491B475(1)010A(2)	0.5	15.0	3.5
4.7	A	T491A475(1)010A(2)	0.5	6.0	5.0
#4.7	S	T491S475(1)010A(2)	0.5	6.0	15.0
#4.7	*R	T491R475M010A(2)	0.5	8.0	15.0
6.8	B	T491B685(1)010A(2)	0.7	6.0	3.5
6.8	A	T491A685(1)010A(2)	0.7	6.0	4.0
6.8	T	T491T685(1)010A(2)	0.7	6.0	5.0
#6.8	*S	T491S685M010A(2)	0.7	10.0	15.0
10.0	C	T491C106(1)010A(2)	1.0	6.0	1.8
10.0	B	T491B106(1)010A(2)	1.0	6.0	3.5
#10.0	A	T491A106(1)010A(2)	1.0	6.0	4.0
#10.0	T	T491T106(1)010A(2)	1.0	6.0	5.0
#10.0	*S	T491S106M010A(2)	1.0	10.0	15.0
15.0	C	T491C156(1)010A(2)	1.5	6.0	1.8
15.0	U	T491U156(1)010A(2)	1.5	6.0	1.8
15.0	B	T491B156(1)010A(2)	1.5	6.0	2.8
#15.0	*A	T491A156(1)010A(2)	1.5	8.0	6.0
#15.0	*T	T491T156M010A(2)	1.5	8.0	5.0

*Extended Values

**6 Volt product equivalent to 6.3 volt product.

#Maximum Capacitance Change @ 125°C = 15%.

†Maximum Capacitance Change @ 125°C = +20%.

(1) To complete KEMET Part Number, insert M for ±20% tolerance or K for ±10% tolerance.

Higher voltage ratings and lighter capacitance tolerance product may be substituted within the same size at KEMET's option. Voltage substitutions will be marked with the higher voltage rating.

Note: Refer to T491 Ordering Information on page 15 for lead termination options.

Solid Tantalum Surface Mount

T491 RATINGS & PART NUMBER REFERENCE

Capacitance µF	Case Size	KEMET Part Number	DC Leakage mA @ 25°C Max	DF % @ +25°C 120 Hz Max	ESR W @ +25°C 100 kHz Max
10 Volt Rating at +85°C (7 Volt Rating at +125°C)					
22.0	C	T491C226(1)010A(2)	2.2	6.0	1.8
22.0	U	T491U226(1)010A(2)	2.2	6.0	1.8
#22.0	B	T491B226(1)010A(2)	2.2	6.0	3.0
#22.0	*A	T491A226(1)010A(2)	2.2	10.0	6.0
#22.0	*T	T491T226M010A(2)	2.2	12.0	8.0
33.0	D	T491D336(1)010A(2)	3.3	6.0	0.8
33.0	V	T491V336(1)010A(2)	3.3	6.0	1.2
33.0	C	T491C336(1)010A(2)	3.3	6.0	1.8
#33.0	U	T491U336(1)010A(2)	3.3	6.0	1.8
#33.0	B	T491B336(1)010A(2)	3.3	6.0	3.5
47.0	D	T491D476(1)010A(2)	4.7	6.0	0.8
47.0	V	T491V476(1)010A(2)	4.7	6.0	0.7
#47.0	C	T491C476(1)010A(2)	4.7	6.0	1.2
#47.0	*U	T491U476(1)010A(2)	4.7	10.0	2.2
#47.0	*B	T491B476M010A(2)	4.7	6.0	1.0
68.0	D	T491D686(1)010A(2)	6.8	6.0	0.8
68.0	V	T491V686(1)010A(2)	6.8	6.0	0.7
#68.0	C	T491C686(1)010A(2)	6.8	6.0	1.2
#68.0	*U	T491U686M010A(2)	6.8	10.0	1.8
#68.0	*B	T491B686M010A(2)	6.8	10.0	3.0
100.0	D	T491D107(1)010A(2)	10.0	8.0	0.7
#100.0	*C	T491C107(1)010A(2)	10.0	8.0	1.2
#100.0	V	T491V107(1)010A(2)	10.0	8.0	0.7
150.0	X	T491X157(1)010A(2)	15.0	8.0	0.7
#150.0	D	T491D157(1)010A(2)	15.0	8.0	0.7
#150.0	*C	T491C157(1)010A(2)	15.0	10.0	1.2
#150.0	*V	T491V157M010A(2)	15.0	8.0	0.7
#220.0	X	T491X227(1)010A(2)	22.0	8.0	0.5
#220.0	*D	T491D227(1)010A(2)	22.0	8.0	0.5
#220.0	*V	T491V227(1)010A(2)	22.0	12.0	0.7
#330.0	*D	T491D337M010A(2)	33.0	10.0	0.5
#330.0	*X	T491X337(1)010A(2)	33.0	10.0	0.5
#470.0	*X	T491X477(1)010A(2)	47.0	10.0	0.2
#470.0	*E	T491E477M010A(2)	47.0	12.0	0.5
16 Volt Rating at +85°C (10 Volt Rating at +125°C)					
1.0	A	T491A105(1)016A(2)	0.5	4.0	10.0
1.5	A	T491A155(1)016A(2)	0.5	6.0	8.0
2.2	A	T491A225(1)016A(2)	0.5	6.0	6.0
2.2	*S	T491S225(1)016A(2)	0.5	6.0	15.0
#2.2	*R	T491R225(1)016A(2)	0.5	8.0	25.0
3.3	B	T491B335(1)016A(2)	0.5	6.0	3.5
3.3	A	T491A225(1)016A(2)	0.5	6.0	6.0
4.7	B	T491B475(1)016A(2)	0.8	6.0	3.5
4.7	A	T491A175(1)016A(2)	0.8	6.0	6.0
4.7	T	T491T475(1)016A(2)	0.8	6.0	5.0
6.8	C	T491C685(1)016A(2)	1.1	6.0	1.9
6.8	B	T491B685(1)016A(2)	1.1	6.0	3.5
#6.8	*A	T491A685(1)016A(2)	1.1	6.0	7.0
10.0	C	T491C106(1)016A(2)	1.6	6.0	1.8
10.0	U	T491U106(1)016A(2)	1.6	6.0	1.8
10.0	B	T491B106(1)016A(2)	1.6	6.0	3.5
#10.0	*A	T491A106(1)016A(2)	1.6	10.0	7.0
#10.0	*T	T491T106M016A(2)	1.6	8.0	8.0
15.0	C	T491C156(1)016A(2)	2.4	6.0	1.8
15.0	U	T491U156(1)016A(2)	2.4	6.0	1.8
#15.0	*B	T491B156(1)016A(2)	2.4	6.0	3.0
22.0	D	T491D226(1)016A(2)	3.6	6.0	0.8
22.0	C	T491C226(1)016A(2)	3.6	6.0	1.6
#22.0	*U	T491U226(1)016A(2)	3.6	10.0	3.0
#22.0	*B	T491B226(1)016A(2)	3.6	6.0	2.2
33.0	D	T491D336(1)016A(2)	5.3	6.0	0.8
#33.0	*C	T491C336(1)016A(2)	5.3	6.0	1.2
#33.0	*U	T491U336(1)016A(2)	5.3	12.0	3.0
47.0	D	T491D476(1)016A(2)	7.5	6.0	0.8
47.0	V	T491V476(1)016A(2)	7.5	6.0	0.7
#47.0	*C	T491C476(1)016A(2)	7.5	6.0	1.2
68.0	*V	T491V686(1)016A(2)	10.9	6.0	0.7
68.0	D	T491D686(1)016A(2)	10.9	6.0	0.7

Capacitance µF	Case Size	KEMET Part Number	DC Leakage mA @ 25°C Max	DF % @ +25°C 120 Hz Max	ESR W @ +25°C 100 kHz Max
16 Volt Rating at +85°C (10 Volt Rating at +125°C)					
100.0	X	T491X107(1)016A(2)	16.0	8.0	0.7
100.0	V	T491V107(1)016A(2)	16.0	12.0	0.7
#100.0	*D	T491D107(1)016A(2)	16.0	8.0	0.7
#150.0	*X	T491X157(1)016A(2)	24.0	8.0	0.5
#150.0	*D	T491D157(1)016A(2)	24.0	12.0	0.7
#270.0	*X	T491X227(1)016A(2)	35.2	10.0	0.5
20 Volt Rating at +85°C (13 Volt Rating at +125°C)					
0.68	A	T491A684(1)020A(2)	0.5	4.0	12.0
1.0	A	T491A105(1)020A(2)	0.5	4.0	10.0
1.0	S	T491S105(1)020A(2)	0.5	6.0	18.0
#1.0	R	T491R105M020A(2)	0.5	6.0	30.0
1.5	A	T491A155(1)020A(2)	0.5	6.0	8.0
1.5	S	T491S155(1)020A(2)	0.5	6.0	15.0
2.2	B	T491B225(1)020A(2)	0.5	6.0	3.5
2.2	A	T491A225(1)020A(2)	0.5	6.0	6.0
3.3	B	T491B335(1)020A(2)	0.7	6.0	3.5
#3.3	*A	T491A335(1)020A(2)	0.7	6.0	7.0
3.3	*T	T491T335(1)020A(2)	0.7	6.0	5.0
4.7	C	T491C475(1)020A(2)	1.0	6.0	2.4
4.7	B	T491B475(1)020A(2)	1.0	6.0	3.5
#4.7	*A	T491A475(1)020A(2)	1.0	8.0	6.0
6.8	C	T491C685(1)020A(2)	1.4	6.0	1.9
6.8	U	T491U685(1)020A(2)	1.4	6.0	1.9
#6.8	*B	T491B685(1)020A(2)	1.4	6.0	3.5
10.0	C	T491C106(1)020A(2)	2.0	6.0	1.8
10.0	U	T491U106(1)020A(2)	2.0	6.0	1.8
#10.0	*B	T491B106(1)020A(2)	2.0	6.0	3.0
15.0	D	T491D156(1)020A(2)	3.0	6.0	1.0
15.0	C	T491C156(1)020A(2)	3.0	6.0	1.7
22.0	D	T491D226(1)020A(2)	4.4	6.0	0.8
22.0	V	T491V226(1)020A(2)	4.4	6.0	0.7
#22.0	*D	T491D226(1)020A(2)	4.4	6.0	1.2
33.0	D	T491D336(1)020A(2)	6.6	6.0	0.8
#33.0	*C	T491C336M020A(2)	6.6	6.0	1.2
#33.0	*V	T491V336(1)020A(2)	6.6	8.0	0.7
47.0	*D	T491D476(1)020A(2)	9.4	6.0	0.7
68.0	X	T491X686(1)020A(2)	13.6	6.0	0.7
#68.0	*D	T491D686(1)020A(2)	13.6	8.0	0.7
#100.0	*X	T491X107(1)020A(2)	20.0	8.0	0.5
25 Volt Rating at +85°C (17 Volt Rating at +125°C)					
0.33	A	T491A334(1)025A(2)	0.5	4.0	15.0
0.47	A	T491A474(1)025A(2)	0.5	4.0	14.0
0.68	A	T491A684(1)025A(2)	0.5	4.0	10.0
1.0	B	T491B105(1)025A(2)	0.5	4.0	5.0
1.0	*A	T491A105(1)025A(2)	0.5	4.0	8.0
1.5	B	T491B155(1)025A(2)	0.5	6.0	5.0
1.5	*A	T491A155(1)025A(2)	0.5	6.0	10.0
2.2	C	T491C225(1)025A(2)	0.6	6.0	3.5
2.2	B	T491B225(1)025A(2)	0.6	6.0	5.0
3.3	C	T491C335(1)025A(2)	0.9	6.0	2.3
3.3	B	T491B335(1)025A(2)	0.9	6.0	3.5
4.7	C	T491C475(1)025A(2)	1.2	6.0	3.4
#4.7	*B	T491B475(1)025A(2)	1.2	6.0	1.5
6.8	C	T491C685(1)025A(2)	1.7	6.0	1.9
6.8	*B	T491B685(1)025A(2)	1.7	6.0	3.0
10.0	D	T491D106(1)025A(2)	2.5	6.0	1.0
#10.0	C	T491C106(1)025A(2)	2.5	6.0	1.5
15.0	D	T491D156(1)025A(2)	3.8	6.0	1.0
#15.0	*C	T491C156(1)025A(2)	3.8	6.0	1.5
22.0	D	T491D226(1)025A(2)	5.5	6.0	0.8
22.0	*C	T491C226(1)025A(2)	5.5	8.0	1.5
22.0	*V	T491V226(1)025A(2)	5.5	6.0	0.7
33.0	X	T491X336(1)025A(2)	8.3	6.0	0.7
#33.0	*D	T491D336(1)025A(2)	8.3	6.0	0.7
#47.0	*X	T491X476(1)025A(2)	11.8	6.0	0.7
#47.0	*D	T491D476(1)025A(2)	11.8	10.0	0.7
#68.0	*X	T491X686M025A(2)	17.0	8.0	0.7

*Extended Values

**6 Volt product equivalent to 6.3 volt product.

#Maximum Capacitance Change @ 125°C = ±15%.

†Maximum Capacitance Change @ 125°C = ±20%.

(1) To complete KEMET Part Number, insert M for ±20% tolerance or K for ±10% tolerance.

Higher voltage ratings and higher capacitance tolerance product may be substituted within the same size at KEMET's option. Voltage substitutions will be marked with the higher voltage rating.

Note: Refer to T491 Ordering Information on page 15 for lead termination options.

SOLID TANTALUM CHIP CAPACITOR

T491 SERIES - Precision Molded Chip



T491 RATINGS & PART NUMBER REFERENCE

Capacitance µF	Case Size	KEMET Part Number	DC Leakage mA @ 25°C Max	DF % @ +25°C 120 Hz Max	ESR W @ +25°C 100 kHz Max
35 Volt Rating at +85°C (23 Volt Rating at +125°C)					
0.10	A	T491A104(1)035A(2)	0.5	4.0	20.0
0.15	A	T491A154(1)035A(2)	0.5	4.0	19.0
0.22	A	T491A224(1)035A(2)	0.5	4.0	18.0
0.33	A	T491A334(1)035A(2)	0.5	4.0	15.0
0.47	B	T491B474(1)035A(2)	0.5	4.0	8.0
0.47	A	T491A474(1)035A(2)	0.5	4.0	14.0
0.68	B	T491B684(1)035A(2)	0.5	4.0	6.5
0.68	*A	T491A684(1)035A(2)	0.5	4.0	10.0
1.0	B	T491B105(1)035A(2)	0.5	4.0	5.0
1.0	*A	T491A105(1)035A(2)	0.5	4.0	10.0
1.5	C	T491C155(1)035A(2)	0.5	6.0	4.5
1.5	B	T491B155(1)035A(2)	0.5	6.0	5.0
2.2	C	T491C225(1)035A(2)	0.8	6.0	3.5
2.2	*B	T491B225(1)035A(2)	0.8	6.0	4.0
3.3	C	T491C335(1)035A(2)	1.2	6.0	2.5
#3.3	*B	T491B335(1)035A(2)	1.2	6.0	3.5
4.7	D	T491D475(1)035A(2)	1.7	6.0	1.5
4.7	C	T491C475(1)035A(2)	1.7	6.0	2.5
6.8	D	T491D685(1)035A(2)	2.4	6.0	1.3
6.8	*C	T491C685(1)035A(2)	2.4	6.0	2.0
10.0	D	T491D106(1)035A(2)	3.5	6.0	1.0
#10.0	*C	T491C106M035A(3)	3.5	6.0	2.0
#10.0	*V	T491V106(1)035A(2)	3.5	6.0	2.0
15.0	X	T491X156(1)035A(2)	5.3	6.0	0.9
15.0	D	T491D156(1)035A(2)	5.3	6.0	0.8
22.0	X	T491X226(1)035A(2)	7.7	6.0	0.7
#22.0	*D	T491D226(1)035A(2)	7.7	6.0	0.7
#33.0	*X	T491X336(1)035A(2)	11.6	6.0	0.6
†47.0	*X	T491X476(1)035A(2)	16.5	8.0	0.6
#47.0	*E	T491E476(1)035A(2)	16.5	10.0	0.5
50 Volt Rating at +85°C (33 Volt Rating at +125°C)					
0.10	A	T491A104(1)050A(2)	0.5	4.0	20.0
0.15	B	T491B154(1)050A(2)	0.5	4.0	16.0
0.15	*A	T491A154(1)050A(2)	0.5	4.0	19.0
0.22	B	T491B224(1)050A(2)	0.5	4.0	14.0
0.33	B	T491B334(1)050A(2)	0.5	4.0	10.0
0.47	C	T491C474(1)050A(2)	0.5	4.0	8.0
0.47	*B	T491B474(1)050A(2)	0.5	4.0	9.0
0.68	C	T491C684(1)050A(2)	0.5	4.0	7.0
0.68	*B	T491B684(1)050A(2)	0.5	4.0	8.0
1.0	C	T491C105(1)050A(2)	0.5	4.0	5.5
1.0	*V	T491V105M050A(2)	0.5	4.0	6.0
1.5	D	T491D155(1)050A(2)	0.8	6.0	3.5
1.5	*C	T491C155(1)050A(2)	0.8	6.0	4.5
2.2	D	T491D225(1)050A(2)	1.1	6.0	2.5
2.2	*C	T491C225(1)050A(2)	1.1	6.0	3.5
3.3	D	T491D335(1)050A(2)	1.7	6.0	2.0
4.7	D	T491D475(1)050A(2)	2.4	6.0	1.5
6.8	X	T491X685(1)050A(2)	3.5	6.0	1.0
#6.8	*D	T491D685(1)050A(2)	3.4	6.0	1.0
#10.0	*X	T491X106M050A(2)	5.0	6.0	0.7
#10.0	*D	T491D106(1)050A(2)	5.0	6.0	0.8
†15.0	*X	T491X156(1)050A(2)	7.5	8.0	0.7

* Extended Values
 ** 6 Volt product equivalent to 6.3 volt product
 # Maximum Capacitance Change @ 125°C = +15%
 † Maximum Capacitance Change @ 125°C = +20%

(1) To complete KEMET Part Number, insert M for ±20% tolerance or K for ±10% tolerance.
 High voltage ratings and higher capacitance tolerance product may be substituted within the same size as KEMET's option. Voltage substitutions will be marked with the higher voltage rating.

Note: Refer to T-91 Ordering Information on page 15 for lead termination options.

CAPACITOR MARKINGS

T491 Series — All Case Sizes

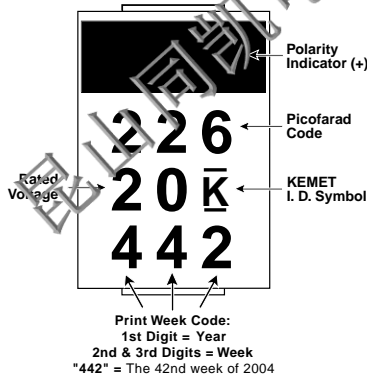

CONSTRUCTION

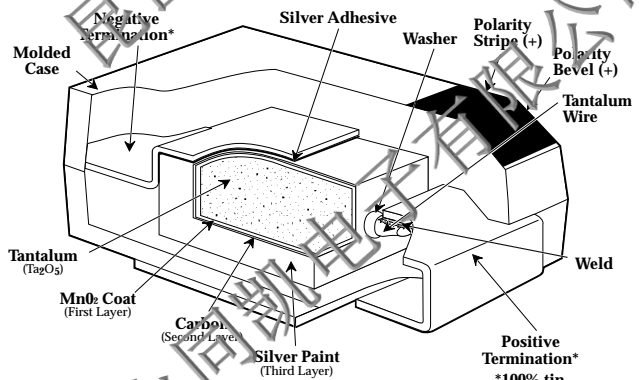

- Established reliability military version of Industrial Grade T491 series
- Taped and reeled per EIA 481-1
- Precision-molded, laser-marked case
- Symmetrical, compliant terminations
- 100% Surge Current test on C, D sizes
- Qualified to MIL-PRF-55365/8, Style CWR11:
 - Termination Code H, solder-plated
 - Weibull failure rate codes B, C and D
 - Capacitance values and voltages as shown in following part number table. (Contact KEMET for latest qualification status)

T492 OUTLINE DRAWINGS

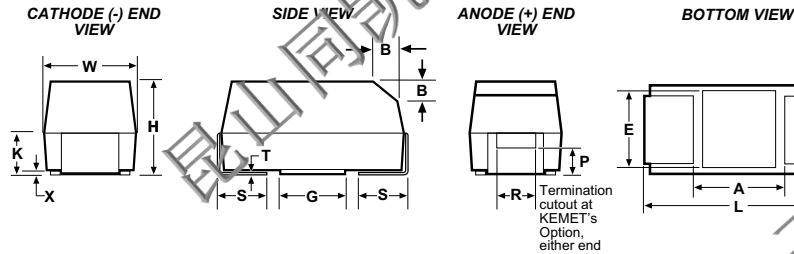

DIMENSIONS – Millimeters (Inches)

CASE SIZE		COMPONENT													
KEMET	EIA	L*	W*	H*	K ± 0.25 $\pm (.008)$	F* ± 0.1 $\pm (.004)$	S* ± 0.3 $\pm (.012)$	B ± 0.15 $(\text{Ref}) \pm (.006)$	T* ± 0.1 (Ref)	P (Ref)	R (Ref)	T (Ref)	A (Min)	G (Ref)	E (Ref)
A	3216-18	3.2 \pm 0.2 (.126 \pm .008)	1.6 \pm 0.2 (.063 \pm .008)	1.6 \pm 0.2 (.063 \pm .008)	0.9 (.035)	1.2 (.047)	0.8 (.031)	0.4 (.016)	0.10 \pm 0.10 (.004 \pm .004)	0.4 (.016)	0.4 (.016)	0.13 (.005)	0.8 (.031)	1.1 (.043)	1.3 (.051)
B	3528-21	3.5 \pm 0.2 (.138 \pm .008)	2.8 \pm 0.2 (.110 \pm .008)	1.9 \pm 0.2 (.075 \pm .008)	1.1 (.043)	2.2 (.087)	0.8 (.031)	0.4 (.016)	0.10 \pm 0.10 (.004 \pm .004)	0.5 (.020)	1.0 (.039)	0.13 (.005)	1.1 (.043)	1.8 (.071)	2.2 (.087)
C	6032-28	6.0 \pm 0.3 (.236 \pm .012)	3.2 \pm 0.3 (.126 \pm .012)	2.5 \pm 0.3 (.098 \pm .012)	1.4 (.055)	2.2 (.087)	1.3 (.051)	0.5 (.020)	0.10 \pm 0.10 (.004 \pm .004)	0.9 (.035)	1.0 (.039)	0.13 (.005)	2.5 (.098)	2.8 (.110)	2.4 (.094)
D	7343-31	7.3 \pm 0.3 (.287 \pm .012)	3.3 \pm 0.3 (.126 \pm .012)	2.8 \pm 0.3 (.110 \pm .012)	1.5 (.059)	2.4 (.094)	1.3 (.051)	0.5 (.020)	0.10 \pm 0.10 (.004 \pm .004)	0.9 (.035)	1.0 (.039)	0.13 (.005)	3.8 (.150)	3.5 (.138)	3.5 (.138)

Notes: 1. Metric dimensions govern. 2. (Ref) - Dimensions provided for reference only. * Mil-C-55365/8 Specified Dimensions

ORDERING INFORMATION — MIL-PRF-55365 Part Number

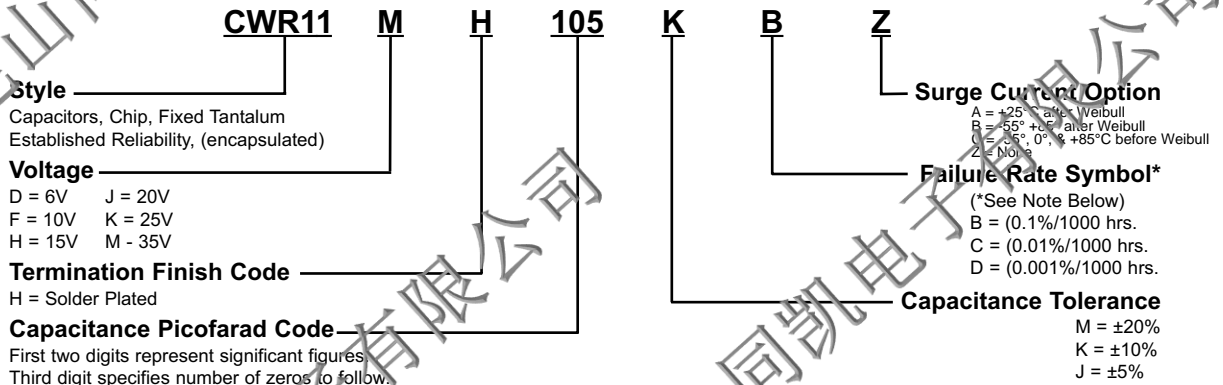

T492 SERIES ORDERING INFORMATION — KEMET Part Number

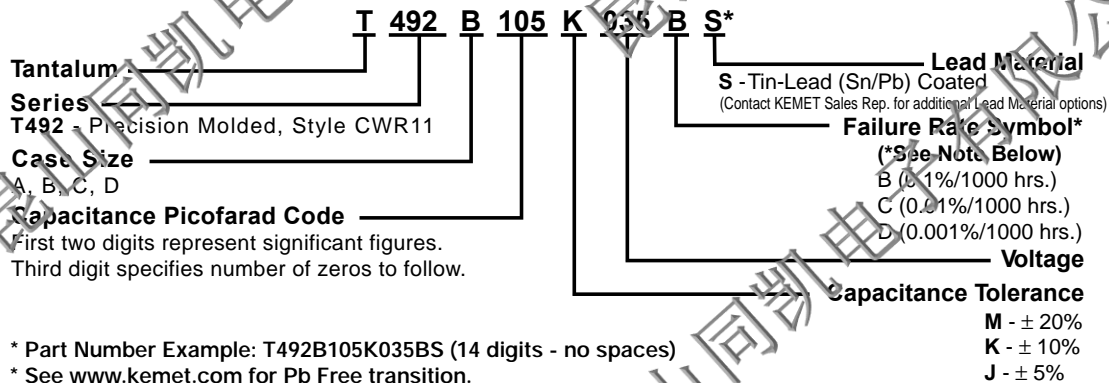

* Part Number Example: T492B105K035BS (14 digits - no spaces)
 * See www.kemet.com for Pb Free transition.
 *Note on Failure Rates: Exponential failure rate levels M, P, R and S are inactive for new design per Mil-C-55365. Parts qualified to Weibull failure rate levels are substitutable for exponential failure rate levels.

SOLID TANTALUM CHIP CAPACITORS

T492 SERIES—Style CWR11 Per Mil-PRF-55365/8



T492 (CWR11) RATINGS AND PART NUMBER REFERENCE

Capacitance μF	Case Size	KEMET Part Number	Mil-C-55365/8 Part Number	DC Leakage μA @ +25°C Max	DF % @ +25°C 120 Hz Max	ESR Ω @ +25°C 100kHz Max
6 Volt Rating at +85°C (4 Volt Rating at +125°C)						
1.5	A	T492A155(1)006(2)S	CWR11DH155(1)(2)	0.5	6.0	8.0
2.2	A	T492A225(1)006(2)S	CWR11DH225(1)(2)	0.5	6.0	8.0
3.3	A	T492A335(1)006(2)S	CWR11DH335(1)(2)	0.5	6.0	8.0
4.7	B	T492B475(1)006(2)S	CWR11DH475(1)(2)	0.5	6.0	5.5
6.8	B	T492B685(1)006(2)S	CWR11DH685(1)(2)	0.5	6.0	4.5
10.0	B	T492B106(1)006(2)S	CWR11DH106(1)(2)	0.6	6.0	3.5
15.0	C	T492C156(1)006(2)S	CWR11DH156(1)(2)	0.9	6.0	3.0
22.0	C	T492C226(1)006(2)S	CWR11DH226(1)(3)	1.4	6.0	2.2
47.0	D	T492D476(1)006(2)S	CWR11DH476(1)(2)	2.8	6.0	1.1
10 Volt Rating at +85°C (7 Volt Rating at 125°C)						
1.0	A	T492A105(1)010(2)S	CWR11FH105(1)(2)	0.5	4.0	10.0
1.5	A	T492A155(1)010(2)S	CWR11FH155(1)(2)	0.5	6.0	8.0
2.2	A	T492A225(1)010(2)S	CWR11FH225(1)(2)	0.5	6.0	8.0
3.3	B	T492B335(1)010(2)S	CWR11FH335(1)(2)	0.5	6.0	5.5
4.7	B	T492B475(1)010(2)S	CWR11FH475(1)(2)	0.5	6.0	4.5
6.8	B	T492B685(1)010(2)S	CWR11FH685(1)(2)	0.7	6.0	3.5
15.0	C	T492C156(1)010(2)S	CWR11FH156(1)(2)	1.5	6.0	2.5
33.0	D	T492D336(1)010(2)S	CWR11FH336(1)(2)	3.3	6.0	1.1
15 Volt Rating at +85°C (10 Volt Rating at +125°C)						
0.68	A	T492A684(1)015(2)S	CWR11HH684(1)(2)	0.5	4.0	12.0
1.0	A	T492A105(1)015(2)S	CWR11HH105(1)(2)	0.5	4.0	10.0
1.5	A	T492A155(1)015(2)S	CWR11HH155(1)(2)	0.5	6.0	8.0
2.2	B	T492B225(1)015(2)S	CWR11HH225(1)(2)	0.5	6.0	5.5
3.3	B	T492B335(1)015(2)S	CWR11HH335(1)(2)	0.5	6.0	5.0
4.7	B	T492B475(1)015(2)S	CWR11HH475(1)(2)	0.7	6.0	4.0
10.0	C	T492C106(1)015(2)S	CWR11HH106(1)(2)	1.6	6.0	2.5
22.0	D	T492D226(1)015(2)S	CWR11HH226(1)(2)	3.3	6.0	1.1
20 Volt Rating at +85°C (13 Volt Rating at +125°C)						
0.47	A	T492A474(1)020(2)S	CWR11JH474(1)(2)	0.5	4.0	14.0
0.68	A	T492A684(1)020(2)S	CWR11JH684(1)(2)	0.5	4.0	12.0
1.0	A	T492A105(1)020(2)S	CWR11JH105(1)(2)	0.5	4.0	10.0
1.5	B	T492B155(1)020(2)S	CWR11JH155(1)(2)	0.5	6.0	6.0
2.2	B	T492B225(1)020(2)S	CWR11JH225(1)(2)	0.5	6.0	5.0
3.3	B	T492B335(1)020(2)S	CWR11JH335(1)(2)	0.7	6.0	4.0
4.7	C	T492C475(1)020(2)S	CWR11JH475(1)(2)	1.0	6.0	3.0
6.8	C	T492C685(1)020(2)S	CWR11JH685(1)(2)	1.4	6.0	2.4
15.0	D	T492D156(1)020(2)S	CWR11JH156(1)(2)	3.0	6.0	1.1
25 Volt Rating at +85°C (17 Volt Rating at +125°C)						
0.33	A	T492A334(1)025(2)S	CWR11KH334(1)(2)	0.5	4.0	15.0
0.47	A	T492A474(1)025(2)S	CWR11KH474(1)(2)	0.5	4.0	14.0
0.68	B	T492B684(1)025(2)S	CWR11KH684(1)(2)	0.5	4.0	7.5
1.0	B	T492B105(1)025(2)S	CWR11KH105(1)(2)	0.5	4.0	6.5
1.5	B	T492B155(1)025(2)S	CWR11KH155(1)(2)	0.5	6.0	6.5
2.2	C	T492C225(1)025(2)S	CWR11KH225(1)(2)	0.6	6.0	3.5
3.3	C	T492C335(1)025(2)S	CWR11KH335(1)(2)	0.9	6.0	3.5
4.7	C	T492C475(1)025(2)S	CWR11KH475(1)(2)	1.2	6.0	2.5
6.8	D	T492D685(1)025(2)S	CWR11KH685(1)(2)	1.7	6.0	1.4
10.0	D	T492D106(1)025(2)S	CWR11KH106(1)(2)	2.5	6.0	1.2
35 Volt Rating at +85°C (23 Volt Rating at +125°C)						
0.10	A	T492A104(1)035(2)S	CWR11MH104(1)(2)	0.5	4.0	24.0
0.15	A	T492A154(1)035(2)S	CWR11MH154(1)(2)	0.5	4.0	21.0
0.22	A	T492A224(1)035(2)S	CWR11MH224(1)(2)	0.5	4.0	18.0
0.33	A	T492A334(1)035(2)S	CWR11MH334(1)(2)	0.5	4.0	15.0
0.47	B	T492B474(1)035(2)S	CWR11MH474(1)(2)	0.5	4.0	10.0
0.68	B	T492B684(1)035(2)S	CWR11MH684(1)(2)	0.5	4.0	8.0
1.0	B	T492B105(1)035(2)S	CWR11MH105(1)(2)	0.5	4.0	6.5
1.5	C	T492C155(1)035(2)S	CWR11MH155(1)(2)	0.5	6.0	4.5
2.2	C	T492C225(1)035(2)S	CWR11MH225(1)(2)	0.8	6.0	3.5
3.3	C	T492C335(1)035(2)S	CWR11MH335(1)(2)	1.2	6.0	2.5
4.7	D	T492D475(1)035(2)S	CWR11MH475(1)(2)	1.7	6.0	1.5

CONSTRUCTION

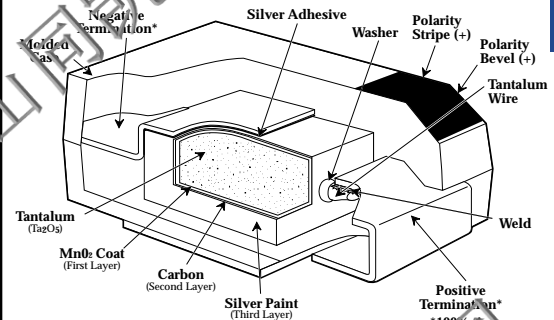

CAPACITOR MARKINGS

T492 Series — All Case Sizes

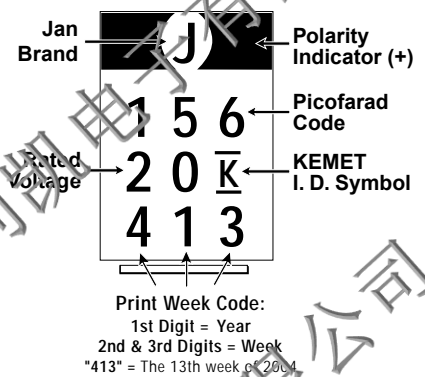

Note on Failure Rates:
Exponential failure rate levels M, P, R and S are inactive for new design per MIL-C-55365. Parts qualified to Weibull failure rate levels are substitutable for exponential failure rate levels.
Note: ESR limits are per Mil-C-55365/8

To complete Part Numbers:

- (1) Insert "M" for ±20% tolerance, "K" for ±10% tolerance or "J" for ±5% tolerance.
- (2) Insert Failure Rate Symbol: B (0.1%/1000 hours), C (0.01%/1000 hours) or D (0.001%/1000 hours).

FEATURES

- Standard Cases Sizes A - X per EIA535BAAC
- Termination Finishes offered per MIL-PRF-55365: Gold Plated, Hot Solder Dipped, Solder Plated, Solder Fused
- Weibull Grading Available: B (0.1%/1000hrs) and C (0.01%/1000hrs)
- Surge Current Testing Available per MIL-PRF-55365: 10 cycles @ +25°C; 10 cycles @ -55°C and +85°C
- Standard and Low ESR Options
- Operating Temperature Range: -55°C to +125°C
- Capacitance: 0.1 to 330µF
- Voltage: 4 to 50 Volts

OUTLINE DRAWING

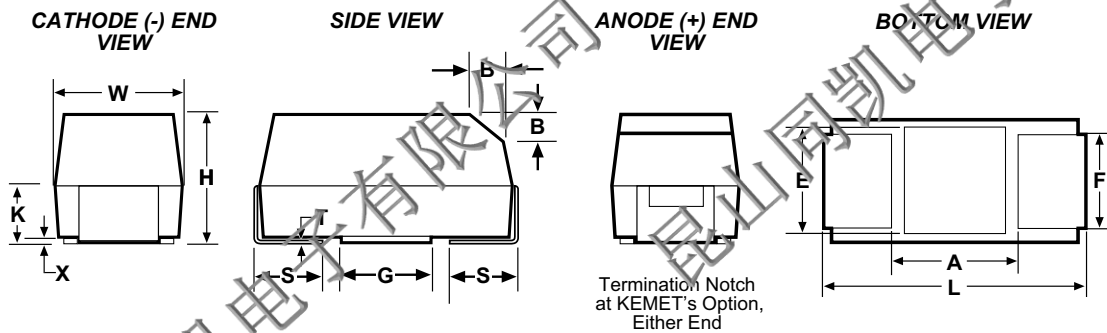

DIMENSIONS- MILLIMETERS (INCHES)

Case Size		L	W	H	±0.20	±0.1	±0.3	B ±0.15	X(Ref)	T(Ref)	A(Min)	G(ref)	E(ref)
KEMET	EIA/IECS				K ±(.008)	F ±(.004)	S ±(.012)	(Ref) ±.006					
A	3216-18	3.2 ± 0.2 (.126 ± .008)	1.6 ± 0.2 (.063 ± .008)	1.6 ± 0.2 (.063 ± .008)	0.9 (.035)	1.2 (.047)	0.8 (.031)	0.4 (.016)	0.10 ± 0.10 (.004 ± .004)	0.13 (.005)	0.8 (.031)	1.1 (.043)	1.3 (.051)
B	3528-21	3.5 ± 0.2 (.138 ± .008)	2.8 ± 0.2 (.110 ± .008)	1.9 ± 0.2 (.075 ± .008)	1.1 (.043)	2.2 (.087)	0.8 (.031)	0.4 (.016)	0.10 ± 0.10 (.004 ± .004)	0.13 (.005)	1.1 (.043)	1.8 (.071)	2.2 (.087)
C	6032-28	6.0 ± 0.3 (.236 ± .012)	3.2 ± 0.3 (.126 ± .012)	2.5 ± 0.3 (.098 ± .012)	1.4 (.055)	2.2 (.087)	1.3 (.051)	0.5 (.020)	0.10 ± 0.10 (.004 ± .004)	0.13 (.005)	2.5 (.098)	2.8 (.110)	2.4 (.094)
D	7343-31	7.3 ± 0.3 (.287 ± .012)	4.3 ± 0.3 (.169 ± .012)	2.8 ± 0.3 (.110 ± .012)	1.7 (.067)	2.4 (.094)	1.3 (.051)	0.5 (.020)	0.10 ± 0.10 (.004 ± .004)	0.13 (.005)	3.8 (.150)	3.5 (.138)	3.5 (.138)
X	7343-43	7.3 ± 0.3 (.287 ± .012)	4.3 ± 0.3 (.169 ± .012)	4.0 ± 0.3 (.157 ± .012)	2.3 (.091)	2.4 (.094)	1.3 (.051)	0.5 (.020)	0.10 ± 0.10 (.004 ± .004)	0.13 (.005)	3.8 (.150)	3.5** (.138)	3.5** (.138)

- Notes: 1. Metric dimensions govern.
 2. (ref) - Dimensions provided for reference only.
 **Round Glue Pad: 2.9 ± 0.1mm, (0.114 ± .004") in diameter at KEMET's option.

COMPONENT MARKING

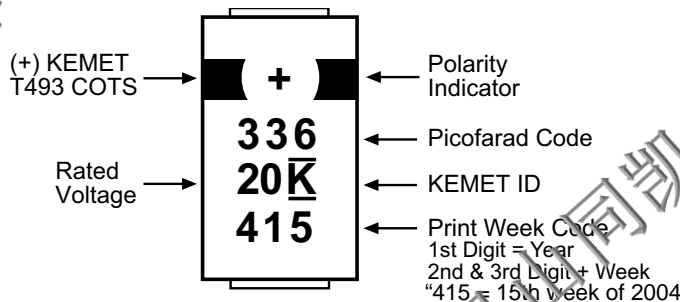

SOLID TANTALUM CHIP CAPACITORS

T493 SERIES—Military COTS



ORDERING INFORMATION

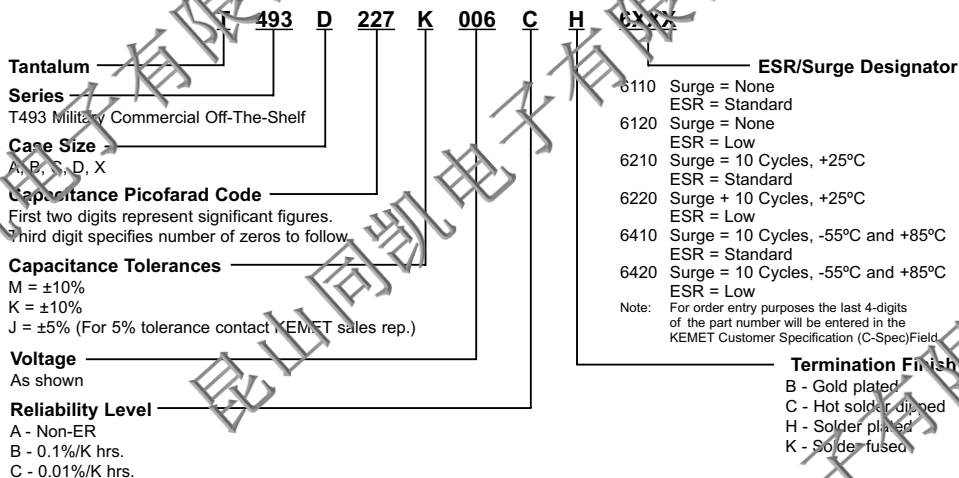

T493 RATINGS AND PART NUMBER REFERENCE

Capacitance µF	Case Size	KEMET Part Number	DCL µA @ 25°C Max	DF % @ +25°C 120 Hz Max	St. ESR Ohms @ +25°C 100 kHz Max	Low ESR Ohms @ +25°C 100 kHz Max
4 Volt Rating at +85°C (2.7 Volt Rating at +125°C)						
2.2	A	T493A225(1)004(2)(3)(4)(5)	0.5	6.0	8.0	6.0
3.3	A	T493A335(1)004(2)(3)(4)(5)	0.5	6.0	8.0	4.0
4.7	A	T493A475(1)004(2)(3)(4)(5)	0.5	6.0	8.0	3.5
6.8	A	T493A685(1)004(2)(3)(4)(5)	0.5	6.0	6.0	3.0
6.8	B	T493B685(1)004(2)(3)(4)(5)	0.5	6.0	5.5	2.0
10.0	A	T493A106(1)004(2)(3)(4)(5)	0.5	6.0	6.0	2.0
10.0	B	T493B106(1)004(2)(3)(4)(5)	0.5	6.0	3.5	1.2
15.0	A	T493A156(1)004(2)(3)(4)(5)	0.6	6.0	4.0	1.5
15.0	B	T493B156(1)004(2)(3)(4)(5)	0.6	6.0	3.5	1.2
22.0	A	T493A226(1)004(2)(3)(4)(5)	0.9	6.0	4.0	1.5
22.0	B	T493B226(1)004(2)(3)(4)(5)	0.9	6.0	3.5	0.6
22.0	C	T493C226(1)004(2)(3)(4)(5)	0.9	6.0	1.8	0.5
33.0	A	T493A336(1)004(2)(3)(4)(5)	1.3	6.0	4.0	3.0
33.0	B	T493B336(1)004(2)(3)(4)(5)	1.3	6.0	3.5	0.5
33.0	C	T493C336(1)004(2)(3)(4)(5)	1.3	6.0	1.8	0.5
47.0	B	T493B476(1)004(2)(3)(4)(5)	1.9	6.0	3.0	0.5
47.0	C	T493C476(1)004(2)(3)(4)(5)	1.9	6.0	1.8	0.5
68.0	B	T493B686(1)004(2)(3)(4)(5)	2.7	6.0	3.5	2.0
68.0	C	T493C686(1)004(2)(3)(4)(5)	2.7	6.0	1.6	0.25
68.0	D	T493D686(1)004(2)(3)(4)(5)	2.7	6.0	0.8	0.2
100.0	B	T493B107(1)004(2)(3)(4)(5)	4.0	8.0	1.0	0.7
100.0	C	T493C107(1)004(2)(3)(4)(5)	4.0	8.0	1.2	0.2
100.0	D	T493D107(1)004(2)(3)(4)(5)	4.0	8.0	0.8	0.2
150.0	C	T493C157(1)004(2)(3)(4)(5)	6.0	8.0	1.2	0.3
150.0	D	T493D157(1)004(2)(3)(4)(5)	6.0	8.0	0.8	0.15
220.0	D	T493D227(1)004(2)(3)(4)(5)	8.8	8.0	0.9	0.7
330.0	D	T493D337(1)004(2)(3)(4)(5)	13.2	8.0	0.7	0.15
330.0	X	T493X337(1)004(2)(3)(4)(5)	13.2	8.0	0.5	0.2
6 Volt Rating at +85°C (4 Volt Rating at +125°C)						
1.5	A	T493A155(1)006(2)(3)(4)(5)	0.5	6.0	8.0	6.0
2.2	A	T493A225(1)006(2)(3)(4)(5)	0.5	6.0	8.0	6.0
3.3	A	T493A335(1)006(2)(3)(4)(5)	0.5	6.0	8.0	6.0
4.7	A	T493A475(1)006(2)(3)(4)(5)	0.5	6.0	6.0	3.5
4.7	B	T493B475(1)006(2)(3)(4)(5)	0.5	6.0	5.5	3.5
6.8	A	T493A685(1)006(2)(3)(4)(5)	0.5	6.0	6.0	2.0
6.8	B	T493B685(1)006(2)(3)(4)(5)	0.5	6.0	3.5	1.2
10.0	A	T493A106(1)006(2)(3)(4)(5)	0.6	6.0	4.0	2.0
10.0	B	T493B106(1)006(2)(3)(4)(5)	0.6	6.0	3.5	1.0
15.0	A	T493A156(1)006(2)(3)(4)(5)	0.9	6.0	4.0	1.5
15.0	B	T493B156(1)006(2)(3)(4)(5)	0.9	6.0	3.5	0.7
15.0	C	T493C156(1)006(2)(3)(4)(5)	0.9	6.0	1.8	0.6
22.0	A	T493A226(1)006(2)(3)(4)(5)	1.4	6.0	4.0	3.0
22.0	B	T493B226(1)006(2)(3)(4)(5)	1.4	6.0	3.5	0.6

- To complete KEMET part number, insert M for ±20% or K for ±10% capacitance tolerance. To request ±5% tolerance, contact KEMET sales representative.
- To complete KEMET part number, insert A for Non-ER; B for 0.1%/1000 Hrs.; or C for 0.01%/1000 Hrs. Reliability Level.
- To complete KEMET part number, insert B for Gold Plated (50 µ inch minimum); C for Hot Solder Dipped (60 µ inch minimum); H for Solder Plated (100 µ inch minimum); or K for Solder Fused (50 µ inch minimum) Termination Finish.
- To complete KEMET part number for Surge Current testing, insert 61 for none; 62 for 10 cycles +25°C; or 64 for 10 cycles, -55°C & +85°C.
- To complete KEMET part number, insert 10 for Standard ESR; or 20 for Low ESR Option.

T493 RATINGS AND PART NUMBER REFERENCE

Capacitance µF	Case Size	KEMET Part Number	DCL µA @ 25°C Max	DF % @ +25°C 120 Hz Max	Std. ESR Ohms @ +25°C 100 kHz Max	Low ESR Ohms @ +25°C 100 kHz Max
6 Volt Rating at +85°C (4 Volt Rating at +125°C) (cont')						
22.0	C	T493C226(1)006(2)(3)(4)(5)	2.0	6.0	1.8	0.5
33.0	B	T493B336(1)006(2)(3)(4)(5)	3.0	6.0	3.0	0.6
33.0	C	T493C336(1)006(2)(3)(4)(5)	2.0	6.0	1.8	0.3
47.0	B	T493B476(1)006(2)(3)(4)(5)	2.9	6.0	3.5	2.0
47.0	C	T493C476(1)006(2)(3)(4)(5)	2.9	6.0	1.6	0.25
47.0	D	T493D476(1)006(2)(3)(4)(5)	2.9	6.0	0.8	0.22
68.0	B	T493B686(1)006(2)(3)(4)(5)	4.1	8.0	1.0	0.65
68.0	C	T493C686(1)006(2)(3)(4)(5)	4.1	6.0	1.2	0.2
68.0	D	T493D686(1)006(2)(3)(4)(5)	4.1	6.0	0.8	0.2
100.0	B	T493B107(1)006(2)(3)(4)(5)	6.3	15.0	10.0	8.0
100.0	C	T493C107(1)006(2)(3)(4)(5)	6.0	8.0	1.2	0.15
100.0	D	T493D107(1)006(2)(3)(4)(5)	6.0	8.0	0.8	0.15
150.0	C	T493C157(1)006(2)(3)(4)(5)	9.0	8.0	1.2	0.3
150.0	D	T493D157(1)006(2)(3)(4)(5)	9.0	8.0	0.7	0.15
220.0	C	T493C227(1)006(2)(3)(4)(5)	13.2	10.0	1.2	0.3
220.0	D	T493D227(1)006(2)(3)(4)(5)	13.2	8.0	0.7	0.1
220.0	X	T493X227(1)006(2)(3)(4)(5)	13.2	8.0	0.7	0.15
10 Volt Rating at +85°C (7 Volt Rating at +125°C)						
1.0	A	T493A105(1)010(2)(3)(4)(5)	0.5	4.0	10.0	6.0
1.5	A	T493A155(1)010(2)(3)(4)(5)	0.5	6.0	8.0	6.0
2.2	A	T493A225(1)010(2)(3)(4)(5)	0.5	6.0	8.0	6.0
3.3	A	T493A335(1)010(2)(3)(4)(5)	0.5	6.0	6.0	4.0
3.3	B	T493B335(1)010(2)(3)(4)(5)	0.5	6.0	5.5	3.5
4.7	A	T493A475(1)010(2)(3)(4)(5)	0.5	6.0	6.0	3.0
4.7	B	T493B475(1)010(2)(3)(4)(5)	0.5	6.0	3.5	1.5
6.8	A	T493A685(1)010(2)(3)(4)(5)	0.7	6.0	6.0	3.0
6.8	B	T493B685(1)010(2)(3)(4)(5)	0.7	6.0	3.5	1.2
10.0	A	T493A106(1)010(2)(3)(4)(5)	1.0	6.0	4.0	1.8
10.0	B	T493B106(1)010(2)(3)(4)(5)	1.0	6.0	3.5	0.8
10.0	C	T493C106(1)010(2)(3)(4)(5)	1.0	6.0	1.8	0.6
15.0	A	T493A156(1)010(2)(3)(4)(5)	1.5	8.0	6.0	4.0
15.0	B	T493B156(1)010(2)(3)(4)(5)	1.5	6.0	3.5	0.7
15.0	C	T493C156(1)010(2)(3)(4)(5)	1.5	6.0	1.8	0.5
22.0	B	T493B226(1)010(2)(3)(4)(5)	2.2	6.0	3.0	0.7
22.0	C	T493C226(1)010(2)(3)(4)(5)	2.2	6.0	1.8	0.4
33.0	B	T493B336(1)010(2)(3)(4)(5)	3.3	6.0	3.5	2.0
33.0	C	T493C336(1)010(2)(3)(4)(5)	3.3	6.0	1.6	0.3
33.0	D	T493D336(1)010(2)(3)(4)(5)	3.3	6.0	0.8	0.3
47.0	C	T493C476(1)010(2)(3)(4)(5)	4.7	6.0	1.2	0.3
47.0	D	T493D476(1)010(2)(3)(4)(5)	4.7	6.0	0.8	0.2
68.0	C	T493C686(1)010(2)(3)(4)(5)	6.8	6.0	1.2	0.3
68.0	D	T493D686(1)010(2)(3)(4)(5)	6.8	6.0	0.8	0.2
68.0	X	T493X686(1)010(2)(3)(4)(5)	5.5	4.0	0.5	0.15
100.0	C	T493C107(1)010(2)(3)(4)(5)	10.0	8.0	1.2	0.3
100.0	D	T493D107(1)010(2)(3)(4)(5)	10.0	8.0	0.7	0.1
150.0	D	T493D157(1)010(2)(3)(4)(5)	15.0	8.0	0.7	0.1
150.0	X	T493X157(1)010(2)(3)(4)(5)	15.0	8.0	0.7	0.2
220.0	D	T493D227(1)010(2)(3)(4)(5)	22.0	8.0	0.5	0.2
220.0	X	T493X227(1)010(2)(3)(4)(5)	22.0	8.0	0.5	0.1
330.0	X	T493X337(1)010(2)(3)(4)(5)	33.0	10.0	0.5	0.1
16 Volt Rating at +85°C (10 Volt Rating at +125°C)						
0.68	A	T493A685(1)016(2)(3)(4)(5)	1.1	6.0	12.0	8.0
1.0	A	T493A105(1)016(2)(3)(4)(5)	0.5	4.0	10.0	6.0
1.5	A	T493A155(1)016(2)(3)(4)(5)	0.5	6.0	8.0	6.0
2.2	A	T493A225(1)016(2)(3)(4)(5)	0.5	6.0	6.0	4.0
3.3	A	T493A335(1)016(2)(3)(4)(5)	0.5	6.0	6.0	3.5
3.3	B	T493B335(1)016(2)(3)(4)(5)	0.5	6.0	3.5	2.0
4.7	A	T493A475(1)016(2)(3)(4)(5)	0.8	6.0	6.0	3.0
4.7	B	T493B475(1)016(2)(3)(4)(5)	0.8	6.0	3.5	1.5
6.8	A	T493A685(1)016(2)(3)(4)(5)	1.1	6.0	7.0	3.0
6.8	B	T493B685(1)016(2)(3)(4)(5)	1.1	6.0	3.5	1.2
6.8	C	T493C685(1)016(2)(3)(4)(5)	1.1	6.0	1.9	0.8
10.0	B	T493B106(1)016(2)(3)(4)(5)	1.6	6.0	3.5	0.8
10.0	C	T493C106(1)016(2)(3)(4)(5)	1.6	6.0	1.8	0.6
15.0	B	T493B156(1)016(2)(3)(4)(5)	2.4	6.0	3.0	0.8
15.0	C	T493C156(1)016(2)(3)(4)(5)	2.4	6.0	1.8	0.4
22.0	B	T493B226(1)016(2)(3)(4)(5)	3.5	6.0	2.2	0.8
22.0	C	T493C226(1)016(2)(3)(4)(5)	3.6	6.0	1.6	0.4
22.0	D	T493D226(1)016(2)(3)(4)(5)	3.6	6.0	0.8	0.3

- (1) To complete KEMET part number, insert M for ±20% or K for ±10% capacitance tolerance. To request ±5% tolerance, contact KEMET sales representative.
- (2) To complete KEMET part number, insert A for Non-ER; B for 0.1%/1000 Hrs.; or C for 0.1%/1000 Hrs. Reliability Level.
- (3) To complete KEMET part number, insert B for Gold Plated (50 µ inch minimum); C for Hot Solder Dipped (60 µ inch minimum); H for Solder Plated (100 µ inch minimum); or K for Solder Fused (60 µ inch minimum Termination Finish).
- (4) To complete KEMET part number for Surge Current testing, insert 61 for none; 62 for 10 cycles +25°C; or 64 for 10 cycles, -55°C & +85°C.
- (5) To complete KEMET part number, insert 10 for Standard ESR; or 20 for Low ESR Option.

SOLID TANTALUM CHIP CAPACITORS

T493 SERIES—Military COTS



T493 RATINGS AND PART NUMBER REFERENCE

Capacitance µF	Case Size	KEMET Part Number	DCL µA @ 25°C Max	DF % @ 25°C 120 Hz Max	ESR Ohms @+25°C 100 kHz Max	Low ESR Ohms @+25°C 100 kHz Max
16 Volt Rating at +85°C (10 Volt Rating at +125°C)						
33.0	C	T493C336(1)016(2)(3)(4)(5)	5.3	6.0	1.2	0.3
33.0	D	T493D336(1)016(2)(3)(4)(5)	5.3	6.0	0.8	0.25
33.0	D	T493D336(1)016(2)(3)(4)(5)	5.3	6.0	0.8	0.3
47.0	C	T493C476(1)016(2)(3)(4)(5)	7.5	6.0	1.2	0.5
47.0	D	T493D476(1)016(2)(3)(4)(5)	7.5	6.0	0.8	0.2
68.0	D	T493D686(1)016(2)(3)(4)(5)	10.9	6.0	0.7	0.2
100.0	D	T493D107(1)016(2)(3)(4)(5)	16.0	8.0	0.7	0.125
100.0	X	T493X107(1)016(2)(3)(4)(5)	16.0	8.0	0.7	0.1
150.0	X	T493X157(1)016(2)(3)(4)(5)	24.0	8.0	0.5	0.2
20 Volt Rating at +85°C (13 Volt Rating at +125°C)						
0.47	A	T493A474(1)020(2)(3)(4)(5)	0.5	4.0	14.0	9.0
0.68	A	T493A684(1)020(2)(3)(4)(5)	0.5	4.0	12.0	8.0
1.0	A	T493A105(1)020(2)(3)(4)(5)	0.5	4.0	10.0	5.5
1.5	A	T493A155(1)020(2)(3)(4)(5)	0.5	6.0	8.0	4.5
1.5	B	T493B155(1)020(2)(3)(4)(5)	0.5	6.0	6.0	4.0
2.2	A	T493A225(1)020(2)(3)(4)(5)	0.5	6.0	7.0	4.0
2.2	B	T493B225(1)020(2)(3)(4)(5)	0.5	6.0	3.5	2.0
3.3	A	T493A335(1)020(2)(3)(4)(5)	0.7	6.0	7.0	4.0
3.3	B	T493B335(1)020(2)(3)(4)(5)	0.7	6.0	3.5	1.3
4.7	A	T493A475(1)020(2)(3)(4)(5)	1.0	8.0	6.0	1.8
4.7	B	T493B475(1)020(2)(3)(4)(5)	1.0	6.0	3.5	1.0
4.7	C	T493C475(1)020(2)(3)(4)(5)	1.0	6.0	3.4	0.6
6.8	B	T493B685(1)020(2)(3)(4)(5)	1.4	6.0	3.5	1.0
6.8	C	T493C685(1)020(2)(3)(4)(5)	1.4	6.0	1.9	0.6
10.0	B	T493B106(1)020(2)(3)(4)(5)	2.0	6.0	3.0	1.0
10.0	C	T493C106(1)020(2)(3)(4)(5)	2.0	6.0	1.8	0.5
15.0	C	T493C156(1)020(2)(3)(4)(5)	3.0	6.0	1.7	0.4
15.0	D	T493D156(1)020(2)(3)(4)(5)	3.0	6.0	1.0	0.35
22.0	C	T493C226(1)020(2)(3)(4)(5)	4.4	6.0	1.2	0.4
22.0	D	T493D226(1)020(2)(3)(4)(5)	4.4	6.0	0.8	0.3
33.0	D	T493D336(1)020(2)(3)(4)(5)	6.6	6.0	0.8	0.2
47.0	D	T493D476(1)020(2)(3)(4)(5)	9.4	6.0	0.7	0.2
47.0	X	T493X476(1)020(2)(3)(4)(5)	7.5	4.0	0.7	0.15
68.0	D	T493D686(1)020(2)(3)(4)(5)	13.6	8.0	0.7	0.2
68.0	X	T493X686(1)020(2)(3)(4)(5)	13.6	6.0	0.7	0.15
25 Volt Rating at +85°C (17 Volt Rating at +125°C)						
0.33	A	T493A334(1)025(2)(3)(4)(5)	0.5	4.0	15.0	10.0
0.47	A	T493A474(1)025(2)(3)(4)(5)	0.5	4.0	14.0	9.0
0.68	A	T493A684(1)025(2)(3)(4)(5)	0.5	4.0	10.0	6.0
0.68	B	T493B684(1)025(2)(3)(4)(5)	0.5	4.0	7.5	5.5
1.0	A	T493A105(1)025(2)(3)(4)(5)	0.5	4.0	8.0	4.0
1.0	B	T493B105(1)025(2)(3)(4)(5)	0.5	4.0	5.0	2.0
1.5	A	T493A155(1)025(2)(3)(4)(5)	0.5	6.0	10.0	3.0
1.5	B	T493B155(1)025(2)(3)(4)(5)	0.5	6.0	5.0	1.5
2.2	B	T493B225(1)025(2)(3)(4)(5)	0.5	6.0	4.5	1.2
2.2	C	T493C225(1)025(2)(3)(4)(5)	0.6	6.0	3.5	2.2
3.3	B	T493B335(1)025(2)(3)(4)(5)	0.9	6.0	3.5	2.0
3.3	C	T493C335(1)025(2)(3)(4)(5)	0.9	6.0	2.5	1.2
4.7	B	T493B475(1)025(2)(3)(4)(5)	1.2	6.0	1.5	0.7
4.7	C	T493C475(1)025(2)(3)(4)(5)	1.2	6.0	2.5	0.6
6.8	C	T493C685(1)025(2)(3)(4)(5)	1.7	6.0	1.9	0.6
6.8	D	T493D685(1)025(2)(3)(4)(5)	1.7	6.0	1.4	1.0
10.0	C	T493C106(1)025(2)(3)(4)(5)	2.5	6.0	1.5	0.5
10.0	D	T493D106(1)025(2)(3)(4)(5)	2.5	6.0	1.0	0.4
15.0	C	T493C156(1)025(2)(3)(4)(5)	3.8	6.0	1.5	0.9
15.0	D	T493D156(1)025(2)(3)(4)(5)	3.8	6.0	1.0	0.35
15.0	X	T493X156(1)025(2)(3)(4)(5)	3.0	6.0	0.7	0.2
22.0	D	T493D226(1)025(2)(3)(4)(5)	5.5	6.0	0.8	0.2
22.0	X	T493X226(1)025(2)(3)(4)(5)	4.4	4.0	0.7	0.23
33.0	X	T493X336(1)025(2)(3)(4)(5)	8.3	6.0	0.7	0.3
47.0	D	T493D476(1)025(2)(3)(4)(5)	11.8	10.0	0.7	0.2
47.0	X	T493X476(1)025(2)(3)(4)(5)	11.8	6.0	0.7	0.3

- (1) To complete KEMET part number, insert M for ±20% or K for ±10% capacitance tolerance. To request ±5% tolerance, contact KEMET sales representative.
- (2) To complete KEMET part number, insert A for Non-ER; B for 0.1%/1000 Hrs.; or C for 0.01%/1000 Hrs. Reliability Level.
- (3) To complete KEMET part number, insert B for Gold Plated (50 µ inch minimum); C for Hot Solder Dipped (50 µ inch minimum); H for Solder Plated (100 µ inch minimum); or K for Solder Fused (60 µ inch minimum Termination Finish).
- (4) To complete KEMET part number for Surge Current testing, insert 61 for none; 62 for 10 cycles @+25°C; or 64 for 10 cycles, -55°C & +85°C.
- (5) To complete KEMET part number, insert 10 for Standard ESR; or 20 for Low ESR Option.



SOLID TANTALUM CHIP CAPACITORS

T493 SERIES—Military COTS

T493 RATINGS AND PART NUMBER REFERENCE

Capacitance µF	Case Size	KEMET Part Number	DCL µA @ 25°C Max	DF % @ +25°C 120 Hz Max	Std. ESR Ohms @+25°C 100 kHz Max	Low ESR Ohms @+25°C 100 kHz Max
35 Volt Rating at +85°C (23 Volt Rating at +125°C)						
0.10	A	T493A104(1)035(2)(3)(4)(5)	0.5	4.0	20.0	10.0
0.15	A	T493A154(1)035(2)(3)(4)(5)	0.5	4.0	19.0	6.0
0.22	A	T493A224(1)035(2)(3)(4)(5)	0.5	4.0	18.0	6.0
0.33	A	T493A334(1)035(2)(3)(4)(5)	0.5	4.0	15.0	6.0
0.47	A	T493A474(1)035(2)(3)(4)(5)	0.5	4.0	14.0	4.0
0.47	B	T493B474(1)035(2)(3)(4)(5)	0.5	4.0	8.0	2.5
0.68	A	T493A684(1)035(2)(3)(4)(5)	0.5	4.0	10.0	6.0
0.68	B	T493B684(1)035(2)(3)(4)(5)	0.5	4.0	6.5	2.5
1.0	A	T493A105(1)035(2)(3)(4)(5)	0.5	4.0	10.0	6.0
1.0	B	T493B105(1)035(2)(3)(4)(5)	0.5	4.0	5.0	2.0
1.5	B	T493B155(1)035(2)(3)(4)(5)	0.5	6.0	5.0	3.0
1.5	C	T493C155(1)035(2)(3)(4)(5)	0.5	6.0	4.5	2.5
2.2	B	T493B225(1)035(2)(3)(4)(5)	0.8	6.0	4.0	2.5
2.2	C	T493C225(1)035(2)(3)(4)(5)	0.8	6.0	3.5	1.5
3.3	B	T493B335(1)035(2)(3)(4)(5)	1.2	6.0	3.5	1.3
3.3	C	T493C335(1)035(2)(3)(4)(5)	1.2	6.0	2.5	0.8
4.7	C	T493C475(1)035(2)(3)(4)(5)	1.7	6.0	2.5	0.6
4.7	D	T493D475(1)035(2)(3)(4)(5)	1.7	6.0	1.5	0.1
6.8	C	T493C685(1)035(2)(3)(4)(5)	2.4	6.0	2.0	0.9
6.8	D	T493D685(1)035(2)(3)(4)(5)	2.4	6.0	1.3	0.5
10.0	C	T493C106(1)035(2)(3)(4)(5)	3.5	6.0	2.0	1.2
10.0	D	T493D106(1)035(2)(3)(4)(5)	3.5	6.0	1.0	0.3
10.0	X	T493X106(1)035(2)(3)(4)(5)	2.8	4.0	0.9	0.25
15.0	D	T493D156(1)035(2)(3)(4)(5)	5.3	6.0	0.8	0.3
15.0	X	T493X156(1)035(2)(3)(4)(5)	5.3	6.0	0.9	0.3
22.0	D	T493D226(1)035(2)(3)(4)(5)	7.7	6.0	0.7	0.4
22.0	X	T493X226(1)035(2)(3)(4)(5)	7.7	6.0	0.7	0.3
33.0	X	T493X336(1)035(2)(3)(4)(5)	11.6	6.0	0.6	0.3
50 Volt Rating at +85°C (33 Volt Rating at +125°C)						
0.10	A	T493A104(1)050(2)(3)(4)(5)	0.5	4.0	20.0	10.0
0.15	A	T493A154(1)050(2)(3)(4)(5)	0.5	4.0	19.0	10.0
0.15	B	T493B154(1)050(2)(3)(4)(5)	0.5	4.0	16.0	10.0
0.22	B	T493B224(1)050(2)(3)(4)(5)	0.5	4.0	14.0	10.0
0.33	B	T493B334(1)050(2)(3)(4)(5)	0.5	4.0	10.0	2.5
0.47	B	T493B474(1)050(2)(3)(4)(5)	0.5	4.0	9.0	2.0
0.47	C	T493C474(1)050(2)(3)(4)(5)	0.5	4.0	8.0	1.8
0.68	C	T493C684(1)050(2)(3)(4)(5)	0.5	4.0	7.0	1.6
1.0	C	T493C105(1)050(2)(3)(4)(5)	0.5	4.0	5.5	1.6
1.5	C	T493C155(1)050(2)(3)(4)(5)	0.8	6.0	4.5	1.5
1.5	D	T493D155(1)050(2)(3)(4)(5)	0.8	6.0	3.5	1.0
2.2	C	T493C225(1)050(2)(3)(4)(5)	1.1	6.0	3.5	1.5
2.2	D	T493D225(1)050(2)(3)(4)(5)	1.1	6.0	2.5	0.8
3.3	D	T493D335(1)050(2)(3)(4)(5)	1.7	6.0	2.0	0.8
4.7	D	T493D475(1)050(2)(3)(4)(5)	2.4	6.0	1.5	0.6
4.7	X	T493X475(1)050(2)(3)(4)(5)	1.9	4.0	0.9	0.3
6.8	X	T493X685(1)050(2)(3)(4)(5)	3.5	6.0	1.0	0.5

- (1) To complete KEMET part number, insert M for ±20% or K for ±10% capacitance tolerance. To request ±5% tolerance, contact KEMET sales representative.
- (2) To complete KEMET part number, insert A for Non-ER; B for 0.1%/1000 Hrs.; or C for 0.01%/1000 Hrs. Reliability Level.
- (3) To complete KEMET part number, insert B for Gold Plated (50 µ inch minimum); C for Hot Solder Dipped (60 µ inch minimum); H for Solder Plated (100 µ inch minimum); or K for Solder Fused (60 µ inch minimum) Termination Finish.
- (4) To complete KEMET part number for Surge Current testing, insert 61 for none; 62 for 10 cycles +25°C; or 64 for 10 cycles, -55°C & +85°C.
- (5) To complete KEMET part number, insert 10 for Standard ESR; or 20 for Low ESR Option.

SOLID TANTALUM CHIP CAPACITORS

T494 SERIES - Low ESR, Industrial Grade



FEATURES

- Low ESR values in EIA 556/AAAC sizes
- Taped and Reeled per EIA 481-1
- Symmetrical, Compliant Terminations
- Optional Gold-plated Terminations
- Laser-marked Case
- 100% Surge Current test on C, D, E, U, V, X sizes
- Capacitance: 0.1 μ F to 1000 μ F
- Tolerance: $\pm 10\%$, $\pm 20\%$
- Voltage: 3-50 VDC
- Extended Range Values
- Low Profile Case Sizes
- RoHS Compliant & Leadfree Terminations (See www.kemet.com for lead transition)

CAPACITOR OUTLINE DRAWING

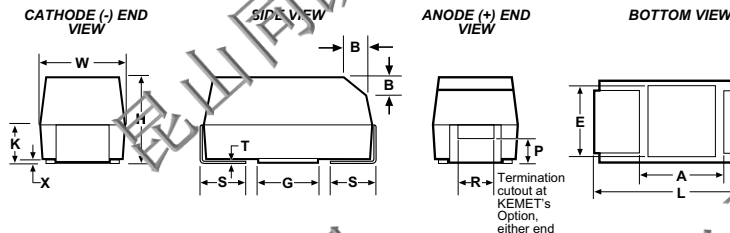

STANDARD T494 DIMENSIONS

Millimeters (inches)

CASE SIZE		COMPONENT													
KEMET	EIA	L*	W*	H*	K*	F*	S*	B ± 0.15	P	R	T	A (Min)	G (Ref)	E (Ref)	
								(Ref) ± (.006)	(Ref)	(Ref)	(Ref)	(Min)	(Ref)	(Ref)	
A	3216-18	3.2 ± 0.2 (.126 ± .008)	1.6 ± 0.2 (.063 ± .008)	1.6 ± 0.2 (.063 ± .008)	0.9 (.035)	1.2 (.047)	0.8 (.031)	0.4 (.016)	0.10 ± 0.10 (.004 ± .004)	0.4 (.016)	0.13 (.005)	0.8 (.031)	1.1 (.043)	1.3 (.051)	
B	3528-21	3.5 ± 0.2 (.138 ± .008)	2.8 ± 0.2 (.110 ± .008)	1.9 ± 0.2 (.075 ± .008)	1.1 (.043)	2.2 (.087)	0.8 (.031)	0.4 (.016)	0.10 ± 0.10 (.004 ± .004)	0.5 (.020)	0.13 (.005)	1.1 (.043)	1.8 (.071)	2.2 (.087)	
C	6032-28	6.0 ± 0.3 (.236 ± .012)	3.2 ± 0.3 (.126 ± .012)	2.5 ± 0.3 (.098 ± .012)	1.4 (.055)	2.2 (.087)	1.3 (.051)	0.5 (.020)	0.10 ± 0.10 (.004 ± .004)	0.9 (.035)	1.0 (.039)	1.3 (.005)	2.5 (.098)	2.8 (.110)	
D	7343-31	7.3 ± 0.3 (.287 ± .012)	4.3 ± 0.3 (.169 ± .012)	2.8 ± 0.3 (.110 ± .012)	1.5 (.059)	2.4 (.094)	1.3 (.051)	0.5 (.020)	0.10 ± 0.10 (.004 ± .004)	0.9 (.035)	1.0 (.039)	1.3 (.005)	3.8 (.150)	3.5 (.138)	
X	7343-43	7.3 ± 0.3 (.287 ± .012)	4.3 ± 0.3 (.169 ± .012)	4.0 ± 0.3 (.157 ± .012)	2.3 (.091)	2.4 (.094)	1.3 (.051)	0.5 (.020)	0.10 ± 0.10 (.004 ± .004)	1.7 (.067)	1.0 (.039)	3.8 (.150)	3.5** (.138)	3.5** (.138)	
E	7240-38	7.3 ± 0.3 (.287 ± .012)	6.0 ± 0.3 (.236 ± .012)	3.6 ± 0.2 (.142 ± .008)	2.3 (.091)	4.1 (.161)	1.3 (.051)	0.5 (.020)	0.10 ± 0.10 (.004 ± .004)	0.9 (.035)	1.0 (.039)	3.8 (.150)	3.5 (.138)	3.5 (.138)	

- Notes: 1. Metric dimensions govern.
 2. (Ref) - Dimensions provided for reference only.
 * Mil-C-55365/8 Specified Dimensions
 ** Round Glue Pad: 2.9 ± 0.1mm (0.114" ± 0.004") in diameter at KEMET's option

LOW PROFILE T494 DIMENSIONS

Millimeters (inches)

CASE SIZE		COMPONENT										
KEMET	EIA	L	W	H Max.	K Min.	F ± 0.1	S ± 0.3	X (Ref)	T (Ref)	A (Min)	G (Ref)	E (Ref)
R	2012-12	2.0 ± 0.2 (.079 ± .008)	1.3 ± 0.2 (.051 ± .008)	1.2 (.047)	0.3 (.012)	0.9 (.035)	0.5 (.020)	0.05 (.002)	0.13 (.005)	0.8 (.031)	0.5 (.020)	0.8 (.031)
S	3216-12	3.2 ± 0.2 (.126 ± .008)	1.6 ± 0.2 (.063 ± .008)	1.2 (.047)	0.3 (.012)	1.2 (.047)	0.8 (.031)	0.05 (.002)	0.13 (.005)	0.8 (.031)	1.1 (.043)	1.3 (.051)
T	3528-12	3.5 ± 0.2 (.138 ± .008)	2.8 ± 0.2 (.110 ± .008)	1.2 (.047)	0.3 (.012)	2.2 (.087)	0.8 (.031)	0.05 (.002)	0.13 (.005)	1.1 (.043)	1.8 (.071)	2.2 (.087)
U	6032-15	6.0 ± 0.3 (.236 ± .012)	3.2 ± 0.3 (.126 ± .012)	1.5 (.059)	0.5 (.020)	2.2 (.087)	1.3 (.051)	0.05 (.002)	0.13 (.005)	2.5 (.098)	2.8 (.110)	2.4 (.094)
V	7343-20	7.3 ± 0.3 (.287 ± .012)	4.3 ± 0.3 (.169 ± .012)	2.0 (.079)	0.9 (.035)	2.4 (.094)	1.3 (.051)	0.05 (.002)	0.13 (.005)	3.8 (.150)	3.5 (.138)	3.5 (.138)

- Notes: 1. Metric dimensions govern.
 2. (Ref) - Dimensions provided for reference only.
 3. No dimensions provided for B, P or R because low profile cases do not have a bevel or a notch.

T494 ORDERING INFORMATION

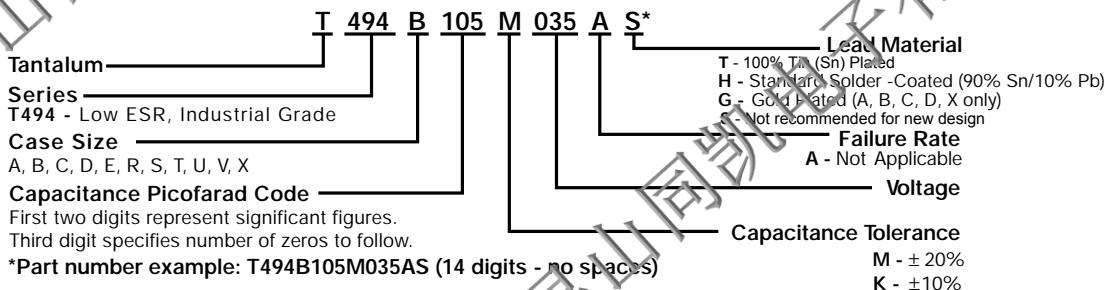



SOLID TANTALUM CHIP CAPACITORS

T494 SERIES—Low ESR, Industrial Grade

T494 RATINGS & PART NUMBER REFERENCE

Capacitance µF	Case Size	KEMET Part Number	DC Leakage µA @ 25°C Max	DF % @ +25°C 120 Hz Max	ESR W @ +25°C 100 kHz Max
2.5 Volt Rating at +85°C (1.7 Volt Rating at +125°C)					
100.0	*T	T494T107(1)2R5A(2)	2.5	24.0	3.5
3 Volt Rating at +85°C (2 Volt Rating at +125°C)					
#33.0	*S	T494A336(1)003A(2)	1.0	6.0	2.0
4 Volt Rating at +85°C (2.7 Volt Rating at +125°C)					
3.3	A	T494A335(1)004A(2)	0.5	6.0	1.0
4.7	A	T494A475(1)004A(2)	0.5	6.0	3.5
6.8	A	T494A685(1)004A(2)	0.5	6.0	3.0
6.8	S	T494S685(1)004A(2)	0.5	6.0	7.0
10.0	B	T494B106(1)004A(2)	0.5	6.0	1.2
10.0	A	T494A106(1)004A(2)	0.5	6.0	2.0
#10.0	*S	T494S106(1)004A(2)	0.5	6.0	9.0
#10.0	*R	T494R106M004A(2)	0.5	6.0	6.0
15.0	B	T494B156(1)004A(2)	0.6	6.0	1.2
15.0	A	T494A156(1)004A(2)	0.6	6.0	1.5
15.0	T	T494T156(1)004A(2)	0.6	6.0	2.0
#15.0	*S	T494S156M004A(2)	0.6	10.0	9.0
22.0	C	T494C226(1)004A(2)	0.9	6.0	0.5
22.0	B	T494B226(1)004A(2)	0.9	6.0	0.6
#22.0	*A	T494A226(1)004A(2)	0.9	6.0	1.5
#22.0	*S	T494S226M004A(2)	0.9	10.0	8.0
#22.0	*T	T494T226(1)004A(2)	0.9	6.0	2.5
33.0	C	T494C336(1)004A(2)	1.3	6.0	0.5
33.0	U	T494U336(1)004A(2)	1.3	6.0	0.6
33.0	B	T494B336(1)004A(2)	1.3	6.0	0.5
#33.0	*A	T494A336(1)004A(2)	1.3	6.0	3.0
#33.0	*T	T494T336M004A(2)	1.3	6.0	3.5
47.0	C	T494C476(1)004A(2)	1.9	6.0	0.5
47.0	U	T494U476(1)004A(2)	1.9	6.0	0.6
#47.0	*B	T494B476(1)004A(2)	1.9	6.0	0.5
#47.0	*A	T494A476M004A(2)	1.9	12.0	2.0
#47.0	T	T494T476M004A(2)	1.9	12.0	4.0
68.0	D	T494D686(1)004A(2)	2.7	6.0	0.20
68.0	C	T494C686(1)004A(2)	2.7	6.0	0.25
#68.0	*U	T494U686(1)004A(2)	2.7	6.0	0.60
#68.0	*B	T494B686(1)004A(2)	2.7	6.0	2.00
#68.0	A	T494A686(1)004A(2)	2.8	30.0	3.00
100.0	D	T494D107(1)006A(2)	4.0	8.0	0.20
#100.0	*C	T494C107(1)006A(2)	4.0	8.0	0.20
#100.0	*U	T494U107(1)006A(2)	4.0	10.0	1.00
#100.0	*B	T494B107M006A(2)	4.0	8.0	0.65
†100.0	*A	T494A107M006A(2)	4.0	30.0	3.00
†100.0	*T	T494T107M006A(2)	4.0	30.0	4.50
150.0	D	T494D157(1)006A(2)	6.0	8.0	0.15
150.0	V	T494V157(1)006A(2)	6.0	8.0	0.20
#150.0	*C	T494C157(1)006A(2)	6.0	8.0	0.30
†150.0	*B	T494B157M006A(2)	6.0	12.0	1.00
#220.0	*V	T494V227(1)006A(2)	8.8	8.0	0.30
#330.0	*D	T494D337(1)006A(2)	13.2	8.0	0.15
#330.0	*C	T494C337(1)006A(2)	13.2	10.0	0.09
†330.0	*V	T494V337(1)006A(2)	13.2	12.0	0.30
#470.0	*X	T494X477(1)006A(2)	18.8	8.0	0.15
#470.0	*D	T494D477(1)006A(2)	18.8	8.0	0.15
#680.0	*X	T494X687M006A(2)	27.2	12.0	0.10
#680.0	D	T494D687M006A(2)	27.2	12.0	0.15
#1000.0	*X	T494X108(1)006A(2)	40.0	12.0	0.10
#1000.0	*E	T494E108M006A(2)	40.0	15.0	0.08
**6 Volt Rating at +85°C (4 Volt Rating at +125°C)					
2.2	R	T494R225(1)006A(2)	0.5	6.0	20.0
2.2	A	T494A225(1)006A(2)	0.5	6.0	6.0
3.3	A	T494A335(1)006A(2)	0.5	6.0	3.0
4.7	A	T494A475(1)006A(2)	0.5	6.0	3.5
4.7	S	T494S475(1)006A(2)	0.5	6.0	9.0
6.8	B	T494B685(1)006A(2)	0.5	6.0	1.2
6.8	A	T494A685(1)006A(2)	0.5	6.0	2.0
#6.8	*S	T494S685(1)006A(2)	0.5	6.0	9.0
#6.8	*R	T494R685(1)006A(2)	0.5	6.0	10.0
10.0	B	T494B106(1)006A(2)	0.6	6.0	1.0
10.0	A	T494A106(1)006A(2)	0.6	6.0	2.0
10.0	T	T494T106(1)006A(2)	0.6	6.0	1.2
#10.0	*S	T494S106M006A(2)	0.6	10.0	9.0
#10.0	*R	T494R106M006A(2)	0.6	8.0	6.0

Capacitance µF	Case Size	KEMET Part Number	DC Leakage µA @ 25°C Max	DF % @ +25°C 120 Hz Max	ESR Ω @ +25°C 100 kHz Max
**6 Volt Rating at +85°C (4 Volt Rating at +125°C)					
15.0	C	T494C156(1)006A(2)	0.9	6.0	0.6
15.0	B	T494B156(1)006A(2)	0.9	6.0	0.7
#15.0	*A	T494A156(1)006A(2)	0.9	6.0	2.0
#15.0	*T	T494T156(1)006A(2)	0.9	6.0	2.5
#15.0	S	T494S156M006A(2)	0.9	10.0	10.0
22.0	C	T494C226(1)006A(2)	1.4	6.0	0.5
22.0	U	T494U226(1)006A(2)	1.4	6.0	0.8
22.0	B	T494B226(1)006A(2)	1.4	6.0	0.6
#22.0	*A	T494A226(1)006A(2)	1.4	6.0	3.0
#22.0	*T	T494T226M006A(2)	1.4	8.0	3.5
33.0	C	T494C336(1)006A(2)	2.0	6.0	0.5
33.0	U	T494U336(1)006A(2)	2.0	6.0	0.6
#33.0	*B	T494B336(1)006A(2)	2.0	6.0	0.0
#33.0	*A	T494A336(1)006A(2)	2.0	12.0	2.0
#33.0	T	T494T336M006A(2)	2.0	12.0	4.0
47.0	D	T494D476(1)006A(2)	2.9	6.0	0.22
47.0	C	T494C476(1)006A(2)	2.9	6.0	0.25
#47.0	*U	T494U476(1)006A(2)	2.9	6.0	0.60
#47.0	*B	T494B476(1)006A(2)	2.9	6.0	0.50
†47.0	*A	T494A476M006A(2)	3.0	12.0	2.50
†47.0	*T	T494T476(1)006A(2)	3.0	24.0	4.00
68.0	D	T494D686(1)006A(2)	4.1	6.0	0.20
#68.0	*C	T494C686(1)006A(2)	4.1	6.0	0.20
#68.0	*U	T494U686(1)006A(2)	4.1	10.0	1.00
#68.0	*B	T494B686M006A(2)	4.1	8.0	0.65
#68.0	*A	T494A686M006A(2)	5.0	30.0	3.00
100.0	D	T494D107(1)006A(2)	6.0	8.0	0.15
100.0	V	T494V107(1)006A(2)	6.0	8.0	0.20
#100.0	*C	T494C107(1)006A(2)	6.0	8.0	0.30
#100.0	U	T494U107M006A(2)	6.0	10.0	1.20
#100.0	*B	T494B107M006A(2)	6.0	15.0	1.50
150.0	D	T494D157(1)006A(2)	9.0	8.0	0.15
#150.0	*C	T494C157M006A(2)	9.0	8.0	0.30
#150.0	*U	T494U157(1)006A(2)	9.0	8.0	0.30
220.0	X	T494X227(1)006A(2)	13.2	8.0	0.15
#220.0	*D	T494D227(1)006A(2)	13.2	8.0	0.15
#220.0	*C	T494C227M006A(2)	13.2	10.0	0.30
#220.0	*V	T494V227M006A(2)	13.2	12.0	0.30
#330.0	*X	T494X337(1)006A(2)	19.8	8.0	0.15
#330.0	*D	T494D337(1)006A(2)	19.8	8.0	0.15
#470.0	*X	T494X477(1)006A(2)	28.2	10.0	0.10
#470.0	*D	T494D477M006A(2)	28.2	12.0	0.15
#680.0	E	T494E687M006A(2)	40.8	12.0	0.10
10 Volt Rating at +85°C (7 Volt Rating at +125°C)					
1.5	A	T494A155(1)010A(2)	0.5	6.0	6.0
2.2	B	T494B225(1)010A(2)	0.5	6.0	1.5
2.2	A	T494A225(1)010A(2)	0.5	6.0	6.0
3.3	A	T494A335(1)010A(2)	0.5	6.0	4.0
3.3	S	T494S335(1)010A(2)	0.5	6.0	9.0
#3.3	*R	T494R335(1)010A(2)	0.3	8.0	20.0
4.7	B	T494B475(1)010A(2)	0.5	6.0	4.0
4.7	A	T494A475(1)010A(2)	0.5	6.0	3.0
#4.7	*S	T494S475(1)010A(2)	0.5	6.0	9.0
#4.7	*R	T494R475M010A(2)	0.5	8.0	8.0
6.8	B	T494B685(1)010A(2)	0.7	6.0	1.2
6.8	A	T494A685(1)010A(2)	0.7	6.0	3.0
#6.8	T	T494T685(1)010A(2)	0.7	6.0	2.0
#6.8	*S	T494S685M010A(2)	0.7	10.0	9.0
10.0	C	T494C106(1)010A(2)	1.0	6.0	0.6
10.0	B	T494B106(1)010A(2)	1.0	6.0	0.8
#10.0	*A	T494A106(1)010A(2)	1.0	6.0	1.8
#10.0	*T	T494T106(1)010A(2)	1.0	6.0	3.5
#10.0	S	T494S106M010A(2)	1.0	10.0	12.0
15.0	C	T494C156(1)010A(2)	1.5	6.0	0.5
15.0	U	T494U156(1)010A(2)	1.5	6.0	0.8
15.0	B	T494B156(1)010A(2)	1.5	6.0	0.7
#15.0	*A	T494A156(1)010A(2)	1.5	8.0	4.0
#15.0	*T	T494T156M010A(2)	1.5	8.0	3.5

*Extended Values

**6 Volt product equivalent to 6.3 VDC product.

(1) To complete KEMET Part Number, insert M for ±20% tolerance or K for ±10% tolerance.

Higher voltage ratings, lower ESR, and tighter capacitance tolerance product may be

substituted within the same size at KEMET's option. Voltage substitutions will be marked

with the higher voltage rating.

#Maximum Capacitance Change @ 125°C=+15%.

†Maximum Capacitance Change @ 125°C=+20%.

SOLID TANTALUM CHIP CAPACITORS

T494 SERIES - Low ESR, Industrial Grade



T494 RATINGS & PART NUMBER REFERENCE

Capacitance µF	Case Size	KEMET Part Number	DC Leakage µA @ 25°C Max	DF % @ +25°C 120 Hz Max	ESR W @ +25°C 100 kHz Max
10 Volt Rating at +5°C (7 Volt Rating at +125°C)					
22.0	C	T494C226(1)010A(2)	2.2	6.0	0.4
22.0	U	T494U226(1)010A(2)	2.2	6.0	0.8
#22.0	E	T494E226(1)010A(2)	2.2	6.0	0.5
#22.0	A	T494A226M010A(2)	2.2	10.0	4.5
#22.0	V	T494V226M010A(2)	2.2	12.0	6.0
33.0	D	T494D336(1)010A(2)	3.3	6.0	0.65
33.0	U	T494U336(1)010A(2)	3.3	6.0	0.30
33.0	C	T494C336(1)010A(2)	3.3	6.0	0.80
#33.0	*U	T494U336(1)010A(2)	3.3	6.0	0.60
#33.0	*B	T494B336(1)010A(2)	3.3	6.0	2.00
47.0	D	T494D476(1)010A(2)	4.7	6.0	0.22
47.0	V	T494V476(1)010A(2)	4.7	6.0	0.30
#47.0	*C	T494C476(1)010A(2)	4.7	6.0	0.30
#47.0	*U	T494U476(1)010A(2)	4.7	10.0	1.20
#47.0	*B	T494B476M010A(2)	4.7	8.0	0.65
68.0	D	T494D686(1)010A(2)	6.8	6.0	0.20
#68.0	*C	T494C686(1)010A(2)	6.8	6.0	0.30
68.0	V	T494V686(1)010A(2)	6.8	6.0	0.30
#68.0	U	T494U686M010A(2)	6.8	10.0	1.20
#68.0	*B	T494B686M010A(2)	6.8	10.0	1.50
100.0	D	T494D107(1)010A(2)	10.0	8.0	0.15
#100.0	*C	T494C107(1)010A(2)	10.0	8.0	0.20
#100.0	*V	T494V107(1)010A(2)	10.0	8.0	0.40
150.0	X	T494X157(1)010A(2)	15.0	8.0	0.15
#150.0	*D	T494D157(1)010A(2)	15.0	8.0	0.15
#150.0	*C	T494C157(1)010A(2)	15.0	10.0	0.90
#150.0	V	T494V157M010A(2)	15.0	8.0	0.30
#220.0	*X	T494X227(1)010A(2)	22.0	8.0	0.15
#220.0	*D	T494D227(1)010A(2)	22.0	8.0	0.15
#220.0	*V	T494V227(1)010A(2)	22.0	12.0	0.50
#330.0	X	T494X337(1)010A(2)	33.0	10.0	0.10
#330.0	*D	T494D337M010A(2)	33.0	10.0	0.15
#470.0	*X	T494X477(1)010A(2)	47.0	10.0	0.10
#470.0	E	T494E477M010A(2)	47.0	12.0	0.10
16 Volt Rating at +85°C (10 Volt Rating at +125°C)					
1.0	A	T494A105(1)020A(2)	0.5	4.0	6.0
1.5	A	T494A155(1)020A(2)	0.5	6.0	6.0
2.2	A	T494A225(1)020A(2)	0.5	6.0	4.0
2.2	*S	T494S225(1)020A(2)	0.5	6.0	10.0
#2.2	*R	T494R225(1)020A(2)	0.5	8.0	20.0
3.3	B	T494B335(1)020A(2)	0.5	6.0	2.0
3.3	A	T494A335(1)020A(2)	0.5	6.0	4.0
4.7	B	T494B475(1)020A(2)	0.8	6.0	1.5
4.7	A	T494A475(1)020A(2)	0.8	6.0	3.0
4.7	T	T494T475(1)020A(2)	0.8	6.0	3.0
6.8	C	T494C685(1)020A(2)	1.1	6.0	0.8
6.8	B	T494B685(1)020A(2)	1.1	6.0	1.2
#6.8	*A	T494A685(1)020A(2)	1.1	6.0	3.0
10.0	C	T494C106(1)020A(2)	1.6	6.0	0.6
10.0	U	T494U106(1)020A(2)	1.6	6.0	1.0
10.0	B	T494B106(1)020A(2)	1.6	6.0	0.8
#10.0	*A	T494A106(1)020A(2)	1.6	10.0	3.0
#10.0	*T	T494T106M016A(2)	1.6	8.0	6.0
15.0	C	T494C156(1)020A(2)	2.4	6.0	0.4
15.0	U	T494U156(1)020A(2)	2.4	6.0	0.8
#15.0	*B	T494B156(1)020A(2)	2.4	6.0	0.8
22.0	D	T494D226(1)016A(2)	3.6	6.0	0.95
22.0	C	T494C226(1)016A(2)	3.6	6.0	1.35
#22.0	*U	T494U226(1)016A(2)	3.6	10.0	1.8
#22.0	*B	T494B226(1)016A(2)	3.6	6.0	1.0
33.0	D	T494D336(1)016A(2)	5.3	6.0	0.25
#33.0	*C	T494C336(1)016A(2)	5.3	6.0	0.30
#33.0	*U	T494U336(1)016A(2)	5.3	12.0	2.20
47.0	D	T494D476(1)016A(2)	7.5	6.0	0.2
47.0	V	T494V476(1)016A(2)	7.5	6.0	0.3
#47.0	*C	T494C476(1)016A(2)	7.5	6.0	0.5
68.0	*D	T494D686(1)016A(2)	10.9	6.0	0.15
#68.0	*V	T494V686(1)016A(2)	10.9	6.0	0.5

Capacitance µF	Case Size	KEMET Part Number	DC Leakage µA @ 25°C Max	DF % @ +25°C 120 Hz Max	ESR W @ +25°C 100 kHz Max
16 Volt Rating at +85°C (10 Volt Rating at +125°C)					
100.0	X	T494X107(1)016A(2)	16.0	8.0	0.15
#100.0	*D	T494D107(1)016A(2)	16.0	8.0	0.15
†100.0	*V	T494V107(1)016A(2)	16.0	12.0	0.5
#150.0	*X	T494X157(1)016A(2)	24.0	8.0	0.15
#150.0	*D	T494D157(1)016A(2)	24.0	12.0	0.4
#220.0	*X	T494X227(1)016A(2)	35.2	10.0	0.4
20 Volt Rating at +85°C (13 Volt Rating at +125°C)					
0.68	A	T494A684(1)020A(2)	0.5	4.0	8.0
1.0	A	T494A105(1)020A(2)	0.5	4.0	5.5
1.0	S	T494S105(1)020A(2)	0.5	6.0	10.0
†1.0	R	T494R105M020A(2)	0.2	6.0	15.0
1.5	A	T494A155(1)020AS(2)	0.5	6.0	6.5
1.5	S	T494S155(1)020A(2)	0.5	6.0	9.0
2.2	B	T494B225(1)020A(2)	0.5	6.0	1.5
2.2	A	T494A225(1)020A(2)	0.5	6.0	4.0
3.3	B	T494B335(1)020A(2)	0.7	6.0	1.3
#3.3	*A	T494A335(1)020A(2)	0.7	6.0	4.0
3.3	*T	T494T335(1)020A(2)	0.7	6.0	4.0
4.7	C	T494C475(1)020A(2)	1.0	6.0	0.6
4.7	B	T494B475(1)020A(2)	1.0	6.0	1.0
#4.7	*A	T494A475(1)020A(2)	1.0	8.0	3.0
6.8	C	T494C685(1)020A(2)	1.4	6.0	0.6
6.8	U	T494U685(1)020A(2)	1.4	6.0	1.4
#6.8	*B	T494B685(1)020A(2)	1.4	6.0	1.0
10.0	C	T494C106(1)020A(2)	2.0	6.0	0.5
10.0	U	T494U106(1)020A(2)	2.0	6.0	0.8
#10.0	*B	T494B106(1)020A(2)	2.0	6.0	1.0
15.0	D	T494D156(1)020A(2)	3.0	6.0	0.35
15.0	*C	T494C156(1)020A(2)	3.0	6.0	0.40
22.0	D	T494D226(1)020A(2)	4.4	6.0	0.3
22.0	V	T494V226(1)020A(2)	4.4	6.0	0.4
#22.0	*C	T494C226(1)020A(2)	4.4	6.0	0.4
33.0	D	T494D336(1)020A(2)	6.6	6.0	0.25
#33.0	*C	T494C336M020A(2)	6.6	6.0	0.40
†33.0	*U	T494U336(1)020A(2)	6.6	8.0	0.40
47.0	*D	T494D476(1)020A(2)	9.4	6.0	0.2
68.0	X	T494X686(1)020A(2)	13.6	6.0	0.2
#68.0	*D	T494D686(1)020A(2)	13.6	8.0	0.2
#100.0	*X	T494X107(1)020A(2)	20.0	8.0	0.15
25 Volt Rating at +85°C (17 Volt Rating at +125°C)					
0.33	A	T494A334(1)025A(2)	0.5	4.0	10.0
0.47	A	T494A474(1)025A(2)	0.5	4.0	9.0
0.68	A	T494A684(1)025A(2)	0.5	4.0	6.0
1.0	B	T494B105(1)025A(2)	0.5	4.0	2.0
1.0	*A	T494A105(1)025A(2)	0.5	4.0	4.0
1.5	B	T494B155(1)025A(2)	0.5	6.0	1.5
1.5	*A	T494A155(1)025A(2)	0.5	6.0	3.0
2.2	C	T494C225(1)025A(2)	0.6	6.0	2.2
2.2	B	T494B225(1)025A(2)	0.6	6.0	1.2
3.3	C	T494C335(1)025A(2)	0.9	6.0	2.2
3.3	*B	T494B335(1)025A(2)	0.9	6.0	2.0
4.7	C	T494C475(1)025A(2)	1.2	6.0	0.6
#4.7	*B	T494B475(1)025A(2)	1.2	6.0	1.0
6.8	C	T494C685(1)025A(2)	1.7	6.0	0.6
6.8	*B	T494B685(1)025A(2)	1.7	8.0	2.0
10.0	D	T494D106(1)025A(2)	2.5	6.0	0.4
10.0	*C	T494C106(1)025A(2)	2.5	6.0	0.6
15.0	D	T494D156(1)025A(2)	3.8	6.0	0.35
#15.0	*C	T494C156(1)025A(2)	3.8	6.0	0.90
22.0	D	T494D226(1)025A(2)	5.5	6.0	0.3
22.0	*C	T494C226(1)020A(2)	5.5	8.0	1.0
22.0	*V	T494V226(1)025A(2)	5.5	6.0	0.5
33.0	X	T494X336(1)025A(2)	8.3	6.0	0.3
#33.0	*D	T494D336(1)025A(2)	8.3	6.0	0.4
#47.0	*X	T494X476(1)025A(2)	11.8	6.0	0.3
†47.0	*D	T494D476(1)025A(2)	11.8	10.0	0.2
†68.0	*X	T494X686M025A(2)	17.0	8.0	0.3

Note: Refer to T494 Ordering Information on page 27 for lead termination options

*Extended Values

**6 Volt product equivalent to 6.3 volt product.

(1) To complete KEMET Part Number, insert M for ±20% tolerance or K for ±10% tolerance. Higher voltage ratings, lower ESR, and tighter capacitance tolerance product may be substituted within the same size, at KEMET's option. Voltage substitutions will be marked with the higher voltage rating.

#Maximum Capacitance Change @ 125°C=+15%.

†Maximum Capacitance Change @ 125°C=+20%.

Solid Tantalum Surface Mount

T494 RATINGS & PART NUMBER REFERENCE

Capacitance µF	Case Size	KEMET Part Number	DC Leakage µA @ 25°C Max	DF @ +25°C 120 Hz Max	ESR W @ +25°C 100 kHz Max
35 Volt Rating at +85°C (23 Volt Rating at +125°C)					
0.10	A	T494A104(1)035A(2)	0.5	4.0	10.0
0.15	A	T494A154(1)035A(2)	0.5	4.0	6.0
0.22	A	T494A224(1)035A(2)	0.5	4.0	6.0
0.33	A	T494A334(1)035A(2)	0.5	4.0	6.0
0.47	B	T494B474(1)035A(2)	0.5	4.0	2.5
0.47	A	T494A474(1)035A(2)	0.5	4.0	4.0
0.68	B	T494B684(1)035A(2)	0.5	4.0	2.5
0.68	*A	T494A684(1)035A(2)	0.5	4.0	6.0
1.0	B	T494B105(1)035A(2)	0.5	4.0	2.0
1.0	*A	T494A105(1)035A(2)	0.5	4.0	6.0
1.5	C	T494C155(1)035A(2)	0.5	6.0	2.5
1.5	B	T494B155(1)035A(2)	0.5	6.0	3.0
2.2	C	T494C225(1)035A(2)	0.8	6.0	1.5
2.2	*B	T494B225(1)035A(2)	0.8	6.0	2.5
3.3	C	T494C335(1)035A(2)	1.2	6.0	0.8
3.3	*B	T494B335(1)035A(2)	1.2	6.0	1.3
4.7	D	T494D475(1)035A(2)	1.7	6.0	0.7
4.7	C	T494C475(1)035A(2)	1.7	6.0	0.7
6.8	D	T494D685(1)035A(2)	2.4	6.0	0.5
6.8	*C	T494C685(1)035A(2)	2.4	6.0	0.9
10.0	D	T494D106(1)035A(2)	3.5	6.0	0.4
#10.0	*C	T494C106(1)035A(2)	3.5	6.0	1.2
#10.0	*V	T494V106(1)035A(2)	3.5	6.0	0.8
15.0	X	T494X156(1)035A(2)	5.3	6.0	0.3
15.0	*D	T494D156(1)035A(2)	5.3	6.0	0.9
#22.0	X	T494X226(1)035A(2)	7.7	6.0	0.3
#22.0	*D	T494D226(1)035A(2)	7.7	6.0	0.4
#33.0	X	T494X336(1)035A(2)	11.6	6.0	0.3
†47.0	E	T494E476(1)035A(2)	16.5	8.0	0.5
†47.0	*E	T494E476(1)035A(2)	16.5	10.0	0.3
50 Volt Rating at +85°C (33 Volt Rating at +125°C)					
0.10	A	T494A104(1)050A(2)	0.5	4.0	10.0
0.15	B	T494B154(1)050A(2)	0.5	4.0	10.0
0.15	*A	T494A154(1)050A(2)	0.5	4.0	10.0
0.22	B	T494B224(1)050A(2)	0.5	4.0	10.0
0.33	B	T494B334(1)050A(2)	0.5	4.0	2.5
0.47	C	T494C474(1)050A(2)	0.5	4.0	1.8
0.47	*B	T494B474(1)050A(2)	0.5	4.0	2.0
0.68	C	T494C684(1)050A(2)	0.5	4.0	1.6
0.68	*B	T494B684(1)050A(2)	0.5	4.0	3.0
1.0	C	T494C105(1)050A(2)	0.5	4.0	1.6
#1.0	*V	T494V105M050A(2)	0.5	4.0	4.0
1.5	D	T494D155(1)050A(2)	0.8	6.0	1.0
1.5	*C	T494C155(1)050A(2)	0.8	6.0	1.5
2.2	D	T494D225(1)050A(2)	1.1	6.0	0.8
2.2	*C	T494C225(1)050A(2)	1.1	6.0	1.5
3.3	D	T494D335(1)050A(2)	1.7	6.0	0.8
4.7	D	T494D475(1)050A(2)	2.4	6.0	0.6
6.8	X	T494X685(1)050A(2)	3.5	6.0	0.5
#6.8	D	T494D685(1)050A(2)	3.4	6.0	0.7
#10.0	X	T494X106M050A(2)	5.0	6.0	0.4
#10.0	*D	T494D106(1)050A(2)	5.0	6.0	0.7
†15.0	*X	T494X156(1)050A(2)	7.5	6.0	0.4

*Extended Values

**6 Volt product equivalent to 6.3 volt product.

(1) To complete KEMET Part Number, insert M for ±20% tolerance or K for ±10% tolerance.

Higher voltage ratings, lower ESR, and tighter capacitance tolerance product may be substituted within the same size at KEMET's option. Voltage substitutions will be marked with the higher voltage rating.

#Maximum Capacitance Change @ 125°C=+15%.

†Maximum Capacitance Change @ 125°C=+20%.

Note: Refer to T494 Ordering Information on page 27 for lead termination options

CAPACITOR MARKINGS T494 Series — All Case Sizes

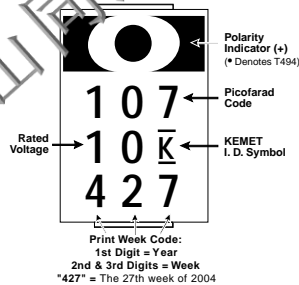

CONSTRUCTION

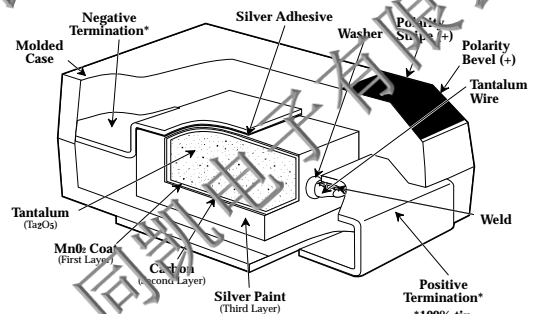

SOLID TANTALUM CHIP CAPACITORS

T495 SERIES - Low ESR, Surge Robust



FEATURES

- Designed for very low ESR
- High ripple current capability
- High surge current capability
- 100% accelerated steady-state aging
- 100% Surge Current test
- Meets or Exceeds EIA Standard 535BAAC
- Available tested per DSCC Dwg. 95158
- New Extended Values for Low ESR
- Low Equivalent Series Inductance (<2.5nH ESL)
- Precision molded, laser-marked case
- Symmetrical, compliant terminations
- Taped and reeled per EIA 481-1
- RoHS Compliant & Leadfree Terminations (see www.kemet.com for lead transition)

OUTLINE DRAWING

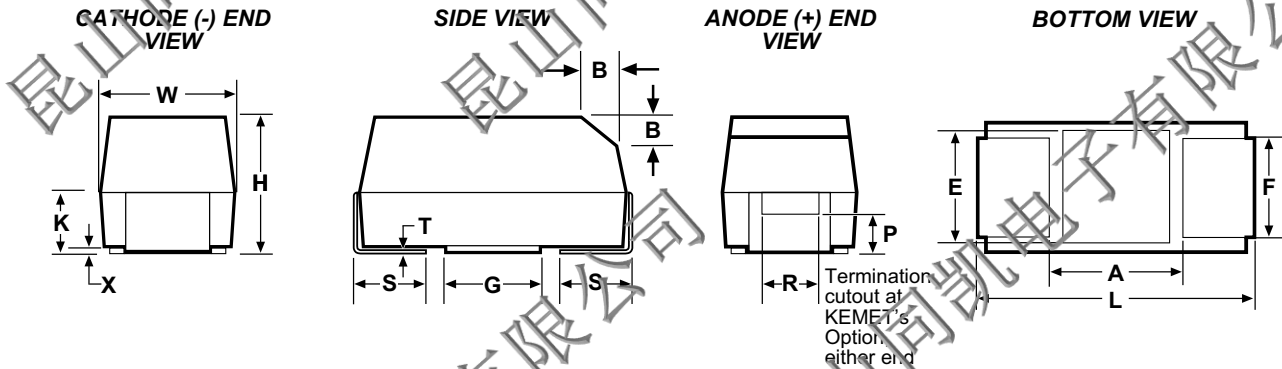

STANDARD T495 DIMENSIONS

Millimeters (Inches)

CASE SIZE		COMPONENT													
KEMA	EIA	L	W	H	K ±0.20 ± (.008)	F ±0.1 ± (.004)	S ±0.3 ± (.012)	B ±0.15 (Ref) ± (.006)	X (Ref)	P (Ref)	R (Ref)	T (Ref)	A (Min)	G (Ref)	E (Ref)
B	3528-21	3.5 ± 0.2 (.138 ± .008)	2.9 ± 0.2 (.110 ± .008)	1.9 ± 0.2 (.075 ± .008)	1.1 (.043)	2.2 (.087)	0.8 (.031)	0.4 (.016)	0.10 ± 0.10 (.004 ± .004)	0.5 (.020)	1.0 (.039)	0.13 (.005)	1.1 (.043)	1.8 (.071)	2.2 (.087)
C	6032-28	6.7 ± 0.3 (.263 ± .012)	3.2 ± 0.3 (.126 ± .012)	2.5 ± 0.3 (.098 ± .012)	1.4 (.055)	2.2 (.087)	1.3 (.051)	0.5 (.020)	0.10 ± 0.10 (.004 ± .004)	0.9 (.035)	1.0 (.039)	0.13 (.005)	2.5 (.098)	2.8 (.110)	2.4 (.094)
D	7348-31	7.3 ± 0.3 (.287 ± .012)	4.3 ± 0.3 (.169 ± .012)	2.8 ± 0.3 (.110 ± .012)	1.5 (.059)	2.4 (.094)	1.3 (.051)	0.5 (.020)	0.10 ± 0.10 (.004 ± .004)	0.9 (.035)	1.0 (.039)	0.13 (.005)	3.8 (.150)	3.5 (.138)	3.5 (.138)
X	7348-43	7.3 ± 0.3 (.287 ± .012)	4.3 ± 0.3 (.169 ± .012)	4.0 ± 0.3 (.157 ± .012)	2.3 (.091)	2.4 (.094)	1.3 (.051)	0.5 (.020)	0.10 ± 0.10 (.004 ± .004)	1.7 (.067)	1.0 (.039)	0.13 (.005)	3.8 (.150)	3.5 (.138)	3.5 (.138)

- Notes: 1. Metric dimensions govern.
 2. (Ref) - Dimensions provided for reference only.
 * Round Glue Pad: 2.9 ± 0.1mm (0.114" ± 0.004") in diameter at KEMET's option.

LOW PROFILE T495 DIMENSIONS

Millimeters (Inches)

CASE SIZE		COMPONENT										
KEMET	EIA	L	W	H Max.	K Min.	F ±0.1	S ±0.3	X (Ref)	T (Ref)	A (Min)	G (Ref)	E (Ref)
T	3528-12	3.5 ± 0.2 (.138 ± .008)	2.8 ± 0.2 (.110 ± .008)	1.2 (.047)	0.3 (.012)	2.2 (.087)	0.8 (.031)	0.05 (.002)	0.13 (.005)	1.1 (.043)	1.8 (.071)	2.2 (.087)
V	7343-20	7.3 ± 0.3 (.287 ± .012)	4.3 ± 0.3 (.169 ± .012)	2.0 (0.079)	0.9 (.035)	2.4 (.094)	1.3 (.051)	0.05 (.002)	0.13 (.005)	3.8 (.150)	3.5 (.138)	3.5 (.138)

- Notes: 1. Metric dimensions govern.
 2. (Ref) - Dimensions provided for reference only.
 3. No dimensions provided for B, P or R because low profile cases do not have a bevel or a notch.

ORDERING INFORMATION

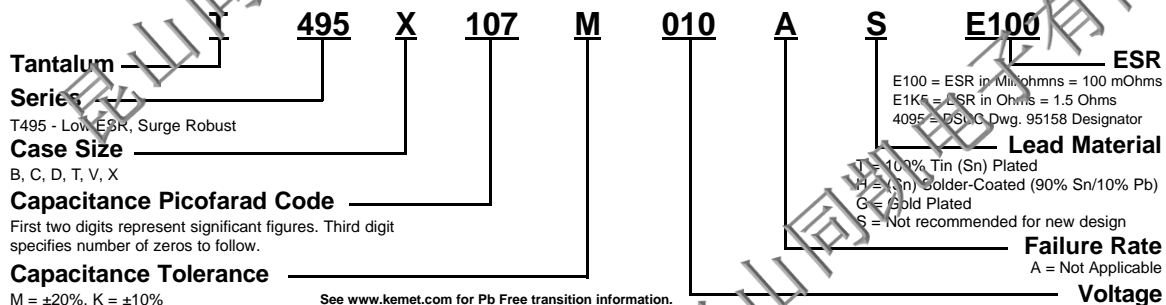



SOLID TANTALUM CHIP CAPACITORS

T495 SERIES—Low ESR, Surge Robust

T495 RATINGS & PART NUMBER REFERENCE

Capacitance μ F	Case Size	KEMET Part Number	DSCC Dwg. No. 95158 Part Number	DC Leakage μ A @ 25°C Max	DF% @ 25°C, 120 Hz	ESR Ω @ 25°C, 100 kHz (Ma)	Ripple Current mA rms @ 25°C, 100 kHz Max		
							25°C	85°C	125°C
2.5 Volt Rating @ +85°C (1.7 Volt Rating at +125°C)									
100.0	T	T495T107M2R5A(2) E3K0		2.5	2.0	3000	153	137	61
4 Volt Rating @ +85°C (2.7 Volt Rating at +125°C)									
100.0	B	T495B107(1)004A(2) E500		4.0	8.0	500	412	371	165
150.0	B	T495B157M004A(2) E900		6.0	12.0	900	307	277	123
330.0	C	T495C337(1)004A(2) E700		3.2	12.0	700	396	357	159
1000.0	X	T495X108(1)004A(2) E070		40.0	12.0	70	1535	1381	614
6/6.3 Volt Rating @ +85°C (4 Volt Rating at +125°C)									
68.0	D	T495D686(1)006A(2)E175		3.3	4.0	175	926	833	370
68.0	D	T495D686(1)006A(2)4095	95158-01(1)(2)	3.3	4.0	175	926	833	370
100.0	*B	T495B107M006A(2)E700		6.3	15.0	700	348	313	139
100.0	C	T495C107(1)006A(2)E150		6.0	8.0	150	856	770	342
100.0	D	T495D107(1)006A(2)E150		6.0	8.0	150	1000	900	400
100.0	V	T495V107(1)006A(2)E090		6.0	8.0	90	1179	1061	471
100.0	V	T495V107(1)006A(2)E150		6.0	8.0	150	913	822	365
150.0	*C	T495C157M006A(2)E200		9.0	8.0	200	742	668	297
150.0	X	T495X157(1)006A(2)E100		7.2	6.0	100	1285	1156	514
150.0	X	T495X157(1)006A(2)4095	95158-02(1)(2)	7.2	6.0	125	1150	1040	460
220.0	*C	T495C227(1)006A(2)E225		13.9	10.0	225	700	600	300
220.0	D	T495D227(1)006A(2)E100		13.9	8.0	100	1225	1102	490
220.0	D	T495D227(1)006A(2)4095	95158-25(1)(2)	13.2	8.0	100	1225	1102	490
220.0	X	T495X227(1)006A(2)E100		13.2	8.0	100	1285	1156	514
220.0	X	T495X227(1)006A(2)4095	95158-03(1)(2)	13.2	8.0	100	1285	1156	514
330.0	*D	T495D337(1)006A(2)E100		20.8	8.0	100	1225	1102	490
330.0	*X	T495X337(1)006A(2)E100		19.8	8.0	100	1285	1156	514
330.0	*X	T495X337(1)006A(2)E065		19.8	8.0	65	1593	1424	637
470.0	*D	T495D477(1)006A(2)E100		29.6	12.0	100	1225	1102	490
470.0	*D	T495D477(1)006A(2)E125		29.6	12.0	125	1095	986	438
470.0	*X	T495X477(1)006A(2)E065		28.2	10.0	65	1593	1424	637
470.0	*X	T495X477(1)006A(2)E050		28.2	10.0	50	1816	1634	726
10 Volt Rating @ +85°C (7 Volt Rating at +125°C)									
22.0	C	T495C226(1)010A(2)E300		2.2	6.0	290	616	554	246
22.0	C	T495C226(1)010A(2)E145		2.2	6.0	345	565	508	226
47.0	D	T495D476(1)010A(2)E080		3.8	4.0	80	1369	1232	548
47.0	D	T495D476(1)010A(2)E090		4.7	6.0	90	1291	1162	516
47.0	D	T495D476(1)010A(2)E200		3.8	4.0	200	866	780	346
47.0	D	T495D476(1)010A(2)4095	95158-04(1)(2)	3.8	4.0	200	866	780	346
68.0	B	T495B686(1)010A(2)E750		1.5	10.0	750	337	303	135
68.0	*B	T495B686M010A(2)E900		6.8	10.0	900	307	276	123
68.0	C	T495C686(1)010A(2)E225		6.8	6.0	225	700	630	280
68.0	V	T495V686(1)010A(2)E140		6.8	6.0	140	945	850	378
68.0	D	T495D686(1)010A(2)E090		6.8	6.0	90	1291	1162	516
68.0	D	T495D686(1)010A(2)E150		6.8	6.0	150	1000	900	400
68.0	X	T495X686(1)010A(2)E150		5.4	4.0	150	1049	944	420
68.0	X	T495X686(1)010A(2)4095	95158-05(1)(2)	5.4	4.0	150	1049	944	420
100.0	V	T495V107(1)010A(2)E150		10.0	8.0	150	913	822	365
100.0	D	T495D107(1)010A(2)E100		10.0	8.0	100	1220	1100	490
100.0	D	T495D107(1)010A(2)4095	95158-06(1)(2)	10.0	8.0	100	1220	1100	490
100.0	*D	T495D107(1)010A(2)E080		10.0	8.0	80	1369	1232	548
100.0	X	T495X107(1)010A(2)E100		8.0	6.0	100	1285	1156	514
100.0	X	T495X107(1)010A(2)4095	95158-07(1)(2)	8.0	6.0	100	1285	1156	514
150.0	V	T495V157(1)010A(2)E100		15.0	8.0	100	1118	1008	447
150.0	*V	T495V157M010A(2)E150		15.0	8.0	150	913	822	365
150.0	D	T495D157(1)010A(2)E100		15.0	8.0	100	1225	1102	490
150.0	D	T495D157(1)010A(2)E080		15.0	8.0	80	1369	1232	548
150.0	D	T495D157(1)010A(2)4095	95158-26(1)(2)	15.0	8.0	100	1225	1102	490
150.0	X	T495X157(1)010A(2)E100		15.0	8.0	100	1285	1156	514
150.0	X	T495X157(1)010A(2)4095	95158-08(1)(2)	15.0	8.0	100	1285	1156	514
150.0	X	T495X157(1)010A(2)E085		15.0	8.0	85	1393	1254	557
220.0	*V	T495V227(1)010A(2)E150		22.0	12.0	150	913	822	365
220.0	D	T495D227(1)010A(2)E075		22.0	8.0	75	1414	1273	566
220.0	D	T495D227(1)010A(2)E100		22.0	8.0	100	1225	1102	490
220.0	D	T495D227(1)010A(2)E125		22.0	8.0	125	1095	986	438
220.0	X	T495X227(1)010A(2)E100		22.0	8.0	100	1285	1156	514
220.0	X	T495X227(1)010A(2)4095	95158-28(1)(2)	15.0	8.0	100	1285	1156	514
220.0	X	T495X227(1)010A(2)E070		22.0	8.0	70	1535	1381	614
330.0	*D	T495D337(1)010A(2)E125		33.0	10.0	125	1095	986	438
330.0	*X	T495X337(1)010A(2)E050		33.0	10.0	50	1816	1634	727
330.0	*X	T495X337(1)010A(2)E060		33.0	10.0	60	1638	1492	663
16 Volt Rating @ +85°C (10 Volt Rating at +125°C)									
10.0	*T	T495T106M016A(2)E100		1.6	8.0	400	122	119	53
33.0	C	T495C336(1)016A(2)E225		5.3	6.0	225	659	629	280
33.0	*C	T495C336(1)016A(2)E275		5.3	6.0	275	632	569	253
33.0	D	T495D336(1)016A(2)E150		6.6	6.0	150	1000	900	400
33.0	D	T495D336(1)016A(2)E175		5.3	6.0	175	926	833	370
33.0	D	T495D336(1)016A(2)E225		4.2	4.0	225	816	735	327
33.0	D	T495D336(1)016A(2)4095	95158-09(1)(2)	4.2	4.0	250	770	700	310
47.0	D	T495D476(1)016A(2)E100		7.5	6.0	100	1225	1102	490
47.0	D	T495D476(1)016A(2)E150		7.5	6.0	150	1000	900	400
47.0	X	T495D476(1)016A(2)4095	95158-10(1)(2)	7.5	6.0	200	870	780	345
68.0	*V	T495V686(1)016A(2)E180		10.9	6.0	180	833	750	333
68.0	V	T495V686(1)016A(2)E300		10.9	6.0	300	645	581	258
68.0	D	T495D686(1)016A(2)E150		10.9	6.0	150	1000	900	400
100.0	*D	T495D107(1)016A(2)E100		16.0	8.0	100	1225	1102	490
100.0	*D	T495D107(1)016A(2)E125		16.0	8.0	125	1095	986	438
100.0	X	T495X107(1)016A(2)E100		16.0	8.0	100	1285	1156	514
100.0	X	T495X107(1)016A(2)4095	95158-11(1)(2)	16.0	8.0	125	1149	1034	460
100.0	X	T495X107(1)016A(2)E080		16.0	8.0	80	1436	1293	574
150.0	*X	T495X157(1)016A(2)E100		24.0	8.0	100	1285	1156	514

- (1) To complete KEMET Part Number, insert M for $\pm 20\%$ or K for $\pm 10\%$ tolerance.
 - (2) To complete KEMET Part Number, insert termination finish as designated on page 31.
- *Extended Values**6 Volt product equivalent to 6.3 volt product.

Note: Refer to T495 Ordering Information on page 31 for lead termination options.

Higher voltage ratings, lower ESR and higher capacitance tolerance product may be substituted within the same size at KEMET's option. Voltage substitutions will be marked with the higher voltage rating.

SOLID TANTALUM CHIP CAPACITORS

T495 SERIES - Low ESR, Surge Robust



Capacitance μ F	Case Size	KEMET Part Number	DSCC Dwg. No. 95158 Part Number	DC Leakage μ A @ 25°C Max	DF% @ 25°C 120 Hz Max	ESR m Ω @ 25°C 100 kHz Max	Ripple Current mA rms @ 20°C		
							100 kHz	85°C	125°C
20 Volt Rating @ +85°C (13 Volt Rating at +125°C)									
15.0	D	T495D156(1)020A(2)E275		2.4	4.0	175	738	665	295
15.0	D	T495D156(1)020A(2)E4095	95158-12(1)(2)	2.4	4.0	275	738	665	295
22.0	D	T495D226(1)020A(2)E180		3.5	4.0	180	913	822	365
22.0	D	T495D226(1)020A(2)E225		3.5	4.0	225	816	735	326
22.0	D	T495D226(1)020A(2)E4095	95158-13(1)(2)	3.5	4.0	275	739	665	295
33.0	D	T495D336(1)020A(2)E150		6.6	6.0	150	1000	900	400
33.0	D	T495D336(1)020A(2)E200		6.6	6.0	200	866	780	346
47.0	D	T495D476(1)020A(2)E175		9.4	6.0	175	926	833	370
47.0	X	T495X476(1)020A(2)E100		9.4	6.0	100	1285	1156	514
47.0	X	T495X476(1)020A(2)E125		9.4	6.0	125	1149	1034	460
47.0	X	T495X476(1)020A(2)E150		7.5	4.0	150	1049	944	420
47.0	X	T495X476(1)020A(2)E4095	95158-14(1)(2)	7.5	4.0	150	1049	944	420
68.0	D	T495D686(1)020A(2)E150		13.6	8.0	150	1000	900	400
68.0	X	T495X686(1)020A(2)E120		13.6	6.0	120	1173	1055	469
68.0	X	T495X686(1)020A(2)E150		13.6	6.0	150	1049	944	420
68.0	X	T495X686(1)020A(2)E4095	95158-15(1)(2)	13.6	6.0	150	1049	944	420
25 Volt Rating @ +85°C (17 Volt Rating at +125°C)									
6.8	*B	T495B685(1)025A(2)E1K5		1.7	6.0	1500	238	214	95
6.8	C	T495C685(1)025A(2)E45		1.7	6.0	490	474	426	190
6.8	C	T495C685(1)025A(2)E500		1.7	6.0	500	469	422	188
10.0	*C	T495C106(1)025A(2)E40		2.5	6.0	450	494	445	198
15.0	D	T495D156(1)025A(2)E225		3.8	6.0	275	738	665	295
15.0	D	T495D156(1)025A(2)E4095	95158-16(1)(2)	3.8	6.0	275	738	665	295
15.0	X	T495X156(1)025A(2)E200		3.0	4.0	200	908	817	363
15.0	X	T495X156(1)025A(2)E4095	95158-17(1)(2)	3.0	4.0	200	908	817	363
22.0	*C	T495C226(1)025A(2)E900		5.5	6.0	900	350	315	140
22.0	*D	T495D226(1)025A(2)E200		5.5	6.0	200	866	780	346
22.0	X	T495X226(1)025A(2)E225		4.4	4.0	225	856	771	343
22.0	X	T495X226(1)025A(2)E4095	95158-18(1)(2)	4.4	4.0	225	856	771	343
33.0	D	T495D336(1)025A(2)E100		8.3	6.0	100	1225	1102	490
33.0	D	T495D336(1)025A(2)E225		8.3	6.0	225	816	735	327
33.0	*D	T495D336(1)025A(2)E300		8.3	6.0	300	707	636	283
33.0	X	T495X336(1)025A(2)E175		6.6	4.0	175	971	874	388
33.0	X	T495X336(1)025A(2)E4095	95158-19(1)(2)	6.6	4.0	175	971	874	388
47.0	*X	T495X476M025A(2)E150		11.8	6.0	150	1049	944	420
47.0	*X	T495X476M025A(2)E175		16.5	8.0	185	944	850	378
47.0	*X	T495X476M025A(2)E200		11.8	6.0	200	908	817	363
47.0	*D	T495D476(1)025A(2)E250		11.8	10.0	250	775	697	310
68.0	*X	T495X686(1)025A(2)E125		17.0	8.0	125	1149	1034	460
68.0	*X	T495X686(1)025A(2)E150		17.0	8.0	150	1049	944	420
68.0	*X	T495X686(1)025A(2)E200		17.0	6.0	200	908	817	363
35 Volt Rating @ +85°C (23 Volt Rating at +125°C)									
4.7	C	T495C475(1)035A(2)E500		1.7	6.0	500	469	422	188
4.7	*C	T495C475(1)035A(2)E600		1.7	6.0	600	428	385	171
4.7	C	T495C475(1)035A(2)E4095	95158-29(1)(2)	1.7	6.0	600	428	385	171
6.8	D	T495D685(1)035A(2)E400		2.4	6.0	400	612	551	245
6.8	X	T495X685(1)035A(2)E300		1.9	4.0	300	742	667	297
6.8	X	T495X685(1)035A(2)E4095	95158-20(1)(2)	1.9	4.0	300	742	667	297
10.0	D	T495D106(1)035A(2)E250		3.5	6.0	250	775	697	310
10.0	D	T495D106(1)035A(2)E300		3.5	6.0	300	707	636	283
10.0	D	T495D106(1)035A(2)E4095	95158-27(1)(2)	3.5	4.0	300	707	636	283
10.0	X	T495X106(1)035A(2)E175		3.5	6.0	175	971	874	388
10.0	X	T495X106(1)035A(2)E200		3.5	6.0	200	908	817	363
10.0	X	T495X106(1)035A(2)E250		2.8	4.0	250	812	731	325
10.0	X	T495X106(1)035A(2)E4095	95158-21(1)(2)	2.8	4.0	250	812	731	325
15.0	D	T495D156(1)035A(2)E225		5.3	6.0	225	816	735	327
15.0	*D	T495D156(1)035A(2)E300		5.3	6.0	300	707	636	283
15.0	*X	T495X156(1)035A(2)E200		5.3	6.0	200	908	817	363
15.0	*X	T495X156(1)035A(2)E225		5.3	6.0	225	856	771	343
15.0	*X	T495X156(1)035A(2)E4095	95158-22(1)(2)	5.3	6.0	225	856	771	343
22.0	D	T495D226(1)035A(2)E200		7.7	6.0	200	866	779	346
22.0	D	T495D226(1)035A(2)E250		7.7	6.0	250	775	697	310
22.0	*D	T495D226(1)035A(2)E300		7.7	6.0	300	707	636	283
22.0	X	T495X226(1)035A(2)E200		7.7	6.0	200	908	817	363
22.0	*X	T495X226(1)035A(2)E275		7.7	6.0	275	775	697	410
22.0	*X	T495X226(1)035A(2)E4095	95158-23(1)(2)	7.7	6.0	300	742	667	297
33.0	X	T495X336(1)035A(2)E175		11.6	6.0	175	971	874	388
33.0	*X	T495X336(1)035A(2)E250		11.6	6.0	250	812	731	325
47.0	X	T495X476(1)035A(2)E185		16.5	8.0	185	944	850	378
47.0	X	T495X476(1)035A(2)E200		16.5	8.0	200	908	817	363
47.0	*X	T495X476(1)035A(2)E300		16.5	8.0	300	742	667	297
50 Volt Rating @ +85°C (33 Volt Rating at +125°C)									
2.2	D	T495D225(1)050A(2)E600		1.1	6.0	600	500	450	200
3.3	D	T495D335(1)050A(2)E200		1.7	6.0	700	583	517	185
4.7	D	T495D475(1)050A(2)E300		2.4	6.0	300	707	636	283
4.7	X	T495X475(1)050A(2)E300		1.9	4.0	300	742	667	297
4.7	X	T495X475(1)050A(2)E4095	95158-24(1)(2)	1.9	4.0	300	742	667	297
6.8	D	T495D685(1)050A(2)E275		3.4	6.0	275	739	665	295
6.8	*D	T495D685(1)050A(2)E300		3.4	6.0	300	700	600	300
10.0	*X	T495X105(1)050A(2)E300		5.0	6.0	300	741	667	297
15.0	*X	T495X155(1)050A(2)E300		7.5	6.0	300	742	667	297

- (1) To complete KEMET Part Number, insert M for $\pm 20\%$ or K for $\pm 10\%$ tolerance.
 (2) To complete KEMET Part Number, insert termination finish as designated on page 31.
 *Extended Values**6 Volt product equivalent to 6.3 volt product.

Higher voltage ratings, lower ESR and tighter capacitance tolerance product may be substituted within the same size at KEMET's option. Voltage substitutions will be marked with the higher voltage rating.

Note: Refer to T495 Ordering Information on page 31 for lead termination options.

CONSTRUCTION

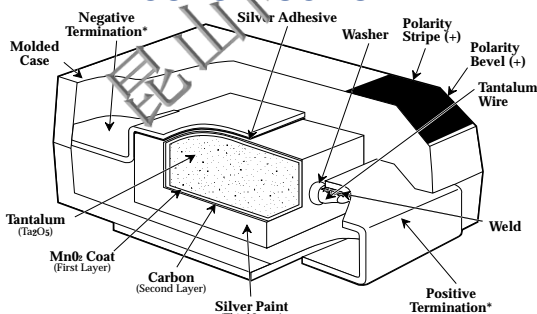

CAPACITOR MARKINGS

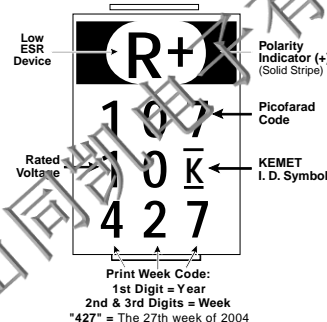

T495 TANTALUM CHIP CAPACITANCE VALUES Case Size and Max. ESR (mΩ) by Capacitance & Voltage

Capacitance		Rated Voltage @ +85°C								
μF	Code	2.5	4	6	10	16	20	25	35	50
4.7	475								C,500,600 D,400	D,300 X,300
6.8	685							B,1500 C,490,500	D,400 X,300	D,275,300
10.0	106					T,4000		C,450	D,300 X,175,200 X,250	X,300
15.0	156						D,275	D,275 X,200	D,225,300 X,225	X,300
22.0	226				C,290,345		D,180,225 275	C, 900 D,200 X,225	D,200,250 D300 X,275,300	
33.0	336					C,225,275 D,150,175, D,225,250	D,150,200	D,100,225,300 X,175	X,175,250	
47.0	476				D,80,90,100, 200	D,100,150, 200	D,175 X,100,125, 150	X,150,200 D,250	X,185,200, 300	
68.0	686			D,175	V,140 B,750,900 C,225 D,90,150 X,150	V,180,300 D,150	D,150 X,120,150	X,125,150 200		
100.0	107	T, 3000	B,500	V,90,150 B,700 C,150	V,150 D, 80,100 X,100	D,100,125 X,80,100, 125				
150.0	157		B,900	C,200 X,100,125	D,80,100 X,85,100 V,150	X,100				
220.0	227			C,225 D,100 X,100	V,150 D,75,100,125 X, 70,100					
330.0	337		C,700	X,65,100 D,100	D,125 X,50,60					
470.0	477			X,50,60 D,100,125						
680.0	687									
1000.0	108		X,70							

Note that standard values are preferred, especially where high surge currents are possible. Extended values are available to increase capacitance and reduce ESR. Note that standard CV values demonstrate inherently lower failure rates than extended CV values, especially in low impedance applications.

SOLID TANTALUM CHIP CAPACITORS

T496 SERIES — Fail-Safe Fused



FEATURES

- Built-in fuse protects against damaging short circuit failure mode
- Precision-molded, laser-marked case
- Symmetrical, compliant terminations
- Taped and reeled per EIA 481-1
- Case geometry and footprints equivalent to Industrial Grade T491 Series. (Case sizes B, C, D and X only)
- 100% Surge Current test on C, D, X sizes
- Patented fuse assembly
- Fuse actuation, 25°C: within 1 second at fault currents of 4 amps and higher.
- Continuous current capability: 0.75 amps
- Post-actuation resistance, 25°C: 10 megohms minimum
- Test tabs on the sides of the case bypass the capacitor element to allow direct testing of the fuse assembly.
- RoHS Compliant & Leadfree Terminations (See www.kemet.com for lead transition)

OUTLINE DRAWINGS

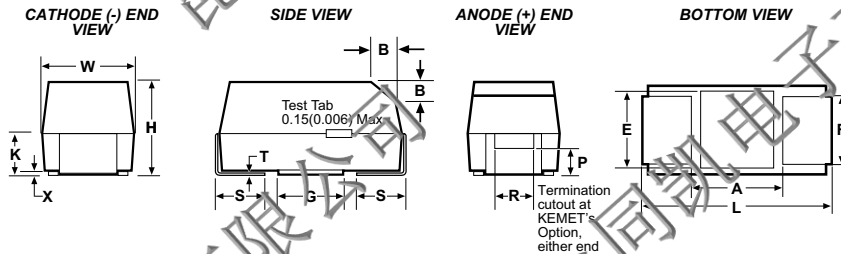

DIMENSIONS — Millimeters (Inches)

CASE SIZE	KEMET	EIA	COMPONENT													
			L	W	H	K ± 0.20 ± (.008)	F ± 0.1 ± (.004)	S ± 0.5 ± (.012)	B ± 0.15 (Ref) ± (.006)	X (Ref)	P (Ref)	R (Ref)	T (Ref)	A (Min)	G (Ref)	E (Ref)
B	3528-21		3.5 ± 0.2 (.138 ± .008)	2.8 ± 0.2 (.112 ± .008)	1.9 ± 0.2 (.075 ± .008)	1.1 (.043)	2.2 (.087)	0.8 (.031)	0.4 (.016)	0.10 ± 0.10 (.004 ± .004)	0.5 (.020)	1.0 (.039)	0.13 (.005)	1.1 (.043)	1.8 (.071)	2.2 (.087)
C	6032-28		6.0 ± 0.3 (.235 ± .012)	3.2 ± 0.3 (.126 ± .012)	2.5 ± 0.3 (.098 ± .012)	1.4 (.055)	2.2 (.087)	1.3 (.051)	0.5 (.020)	0.10 ± 0.10 (.004 ± .004)	0.9 (.035)	1.0 (.039)	0.13 (.005)	2.5 (.098)	2.8 (.110)	2.4 (.094)
D	7343-31		7.3 ± 0.3 (.287 ± .012)	4.3 ± 0.3 (.169 ± .012)	2.8 ± 0.3 (.110 ± .012)	1.5 (.059)	2.4 (.094)	1.3 (.051)	0.5 (.020)	0.10 ± 0.10 (.004 ± .004)	0.9 (.035)	1.0 (.039)	0.13 (.005)	3.8 (.150)	3.5 (.138)	3.5 (.138)
X	7343-43		7.3 ± 0.3 (.287 ± .012)	4.3 ± 0.3 (.169 ± .012)	4.0 ± 0.3 (.157 ± .012)	2.3 (.091)	2.4 (.094)	1.3 (.051)	0.5 (.020)	0.10 ± 0.10 (.004 ± .004)	1.7 (.067)	1.0 (.039)	0.13 (.005)	3.8 (.150)	3.5* (.138)	3.5* (.138)

Notes: 1. Metric dimensions govern.
 2. (Ref) - Dimensions provided for reference only.
 * Round glue pad: 2.9 ± 0.1mm (.114" ± .004") in diameter at KEMET's option.

T496 Series – ORDERING INFORMATION

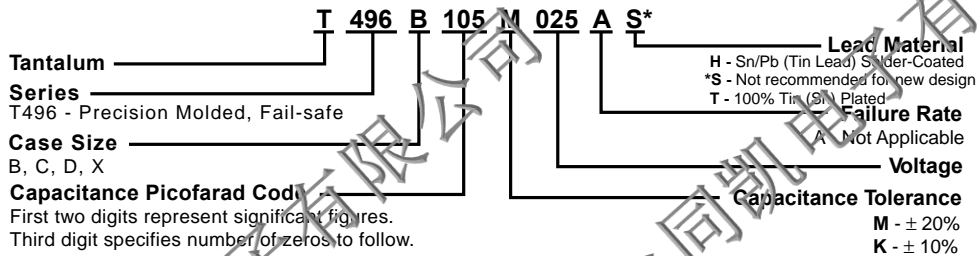

* Part Number Example: T496B105M025AS (14 digits - no spaces)
 * See www.kemet.com for Pb Free transition information.

TYPICAL FUSE ACTUATION PROFILE

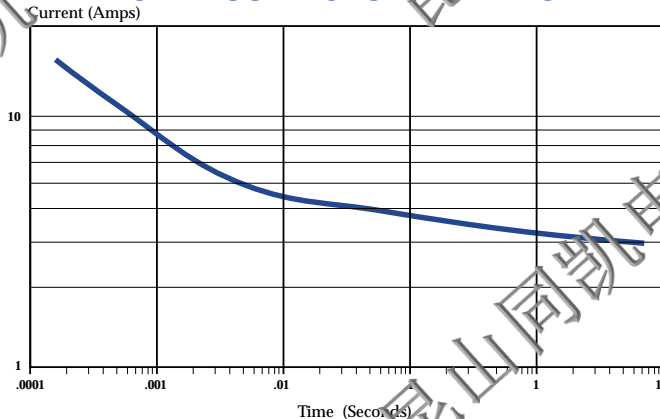

T496 RATINGS & PART NUMBER REFERENCE

Capacitance μ F	Case Size	KEMET Part Number	DCL μ A @ 25°C Max.	DF % @ +25°C 120 Hz. Max.	ESR Ω @ +25°C 100 kHz Max.
4 Volt Rating at +85°C (2.7 Volt Rating at +125°C)					
68.0	*C	T496C686(1)004AS	2.7	6.0	1.6
100.0	*C	T496C107(1)004AS	4.0	8.0	1.2
150.0	D	T496D157(1)004AS	6.0	8.0	0.8
220.0	*D	T496D227(1)004AS	8.8	8.0	0.7
#330.0	*D	T496D337(1)004AS	13.2	8.0	0.7
330.0	*X	T496X337(1)004AS	13.2	8.0	0.7
#470.0	*X	T496X477(1)004AS	18.8	8.0	0.5
**6 Volt Rating at +85°C (4 Volt Rating at +125°C)					
4.7	B	T496B475(1)006AS	0.5	6.0	3.5
6.8	B	T496B685(1)006AS	0.5	6.0	3.5
10.0	B	T496B106(1)006AS	0.6	6.0	3.5
22.0	C	T496C226(1)006AS	1.3	6.0	3.5
15.0	B	T496C156(1)006AS	0.9	6.0	2.0
22.0	C	T496C226(1)006AS	1.4	6.0	2.0
33.0	C	T496C336(1)006AS	2.0	6.0	2.0
47.0	D	T496D476(1)006AS	2.9	6.0	1.0
47.0	*C	T496C476(1)006AS	2.9	6.0	1.6
68.0	D	T496D686(1)006AS	4.1	6.0	1.0
#68.0	*C	T496C686(1)006AS	4.1	6.0	1.2
100.0	X	T496X107(1)006AS	6.0	8.0	0.9
100.0	D	T496D107(1)006AS	6.0	8.0	0.8
150.0	*D	T496D157(1)006AS	9.0	8.0	0.7
#220.0	*D	T496D227(1)006AS	13.2	8.0	0.7
220.0	*X	T496X227(1)006AS	13.2	8.0	0.7
#330.0	*X	T496X337(1)006AS	19.8	8.0	0.5
10 Volt Rating at +85°C (7 Volt Rating at +125°C)					
3.3	B	T496B335(1)010AS	0.5	6.0	3.5
4.7	B	T496B475(1)010AS	0.5	6.0	3.5
6.8	B	T496B685(1)010AS	0.7	6.0	3.5
15.0	B	T496B156(1)010AS	1.5	6.0	3.5
10.0	C	T496C106(1)010AS	1.0	6.0	2.0
15.0	C	T496C156(1)010AS	1.5	6.0	2.0
22.0	C	T496C226(1)010AS	2.2	6.0	2.0
33.0	D	T496D336(1)010AS	3.3	6.0	1.0
33.0	*C	T496C336(1)010AS	3.3	6.0	1.6
47.0	D	T496D476(1)010AS	4.7	6.0	1.0
#47.0	*C	T496C476(1)010AS	4.7	6.0	1.2
68.0	X	T496X685(1)010AS	6.8	6.0	0.9
68.0	D	T496D686(1)010AS	6.8	6.0	0.8
100.0	D	T496D107(1)010AS	10.0	8.0	0.7
150.0	*X	T496X156(1)010AS	15.0	8.0	0.7
#150.0	*D	T496D157(1)010AS	15.0	8.0	0.7
#220.0	*X	T496X227(1)010AS	22.0	8.0	0.5
15 Volt Rating at +85°C (10 Volt Rating at +125°C)					
2.2	B	T496B225(1)016AS	0.5	6.0	3.5
3.3	B	T496B335(1)016AS	0.5	6.0	3.5
4.7	B	T496B475(1)016AS	0.8	6.0	3.5
10.0	B	T496B106(1)016AS	1.6	6.0	3.5
6.8	C	T496C685(1)016AS	1.1	6.0	2.0
10.0	C	T496C106(1)016AS	1.6	6.0	2.0
15.0	C	T496C156(1)016AS	2.4	6.0	2.0
22.0	D	T496D226(1)016AS	3.6	6.0	1.0
22.0	*C	T496C226(1)016AS	3.6	6.0	1.6
33.0	D	T496D336(1)016AS	5.3	6.0	1.0
47.0	X	T496X476(1)016AS	7.5	6.0	0.9
47.0	D	T496D476(1)016AS	7.5	6.0	0.8
100.0	*X	T496X107(1)016AS	16.0	8.0	0.7

Capacitance μ F	Case Size	KEMET Part Number	DCL μ A @ 25°C Max.	DF % @ +25°C 120 Hz. Max.	ESR Ω @ +25°C 100 kHz Max.
20 Volt Rating at +85°C (13 Volt Rating at +125°C)					
1.5	B	T496B155(1)020A(2)	0.5	6.0	5.0
2.2	B	T496B225(1)020A(2)	0.5	6.0	3.5
3.3	B	T496B335(1)020A(2)	0.7	6.0	3.5
4.7	C	T496C475(1)020A(2)	1.0	6.0	2.0
6.8	C	T496C685(1)020A(2)	1.4	6.0	2.0
10.0	C	T496C106(1)020A(2)	2.0	6.0	2.0
15.0	D	T496D156(1)020A(2)	3.0	6.0	1.0
22.0	D	T496D226(1)020A(2)	4.4	6.0	1.0
33.0	X	T496X336(1)020A(2)	6.6	6.0	0.9
47.0	X	T496X476(1)020A(2)	9.4	6.0	0.3
25 Volt Rating at +85°C (17 Volt Rating at +125°C)					
0.68	B	T496B684(1)025A(2)	0.5	4.0	6.5
1.0	B	T496B105(1)025A(2)	0.5	4.0	5.0
1.5	B	T496B155(1)025A(2)	0.5	6.0	5.0
2.2	C	T496C225(1)025A(2)	0.6	6.0	3.5
3.3	C	T496C335(1)025A(2)	0.9	6.0	2.5
4.7	C	T496C475(1)025A(2)	1.2	6.0	2.5
6.8	C	T496C685(1)025A(2)	1.7	6.0	2.0
10.0	C	T496C105(1)025A(2)	2.5	6.0	0.6
10.0	D	T496D106(1)025A(2)	2.5	6.0	1.2
15.0	D	T496D156(1)025A(2)	3.8	6.0	1.0
22.0	X	T496X226(1)025A(2)	5.5	6.0	0.9
22.0	D	T496D226(1)025A(2)	5.5	6.0	0.8
30 Volt Rating at +85°C (23 Volt Rating at +125°C)					
0.47	B	T496B474(1)035A(2)	0.5	4.0	8.0
0.68	B	T496B684(1)035A(2)	0.5	4.0	6.5
1.0	B	T496B105(1)035A(2)	0.5	4.0	5.0
1.5	C	T496C155(1)035A(2)	0.5	6.0	4.5
2.2	C	T496C225(1)035A(2)	0.8	6.0	3.5
3.3	C	T496C335(1)035A(2)	1.2	6.0	2.5
4.7	D	T496D475(1)035A(2)	1.7	6.0	1.5
6.8	D	T496D685(1)035A(2)	2.4	6.0	1.3
10.0	X	T496X106(1)035A(2)	3.5	6.0	1.0
15.0	*X	T496X156(1)035A(2)	5.3	6.0	0.9
22.0	*X	T496X226(1)035A(2)	7.7	6.0	0.3
50 Volt Rating at +85°C (33 Volt Rating at +125°C)					
0.15	B	T496B154(1)050A(2)	0.5	4.0	16.0
0.22	B	T496B224(1)050A(2)	0.5	4.0	14.0
0.33	B	T496B334(1)050A(2)	0.5	4.0	10.0
0.47	C	T496C474(1)050A(2)	0.5	4.0	8.0
0.68	C	T496C684(1)050A(2)	0.5	4.0	7.0
1.0	C	T496C105(1)050A(2)	0.5	4.0	5.5
1.5	C	T496C155(1)050A(2)	0.8	6.0	5.0
2.2	D	T496D225(1)050A(2)	1.1	6.0	2.5
3.3	D	T496D335(1)050A(2)	1.7	6.0	2.0

Higher voltage ratings and higher capacitance tolerance product may be substituted within the same size at KEMET's option. Voltage substitutions will be marked with the higher voltage rating.

** Note: 6V rating equivalent to 6.3 rating *Extended Ratings
Maximum capacitance change @ 125°C = +15% (all others = 12%)

(1) To complete KEMET part number insert M for $\pm 20\%$ or K for $\pm 10\%$ tolerance.

CONSTRUCTION

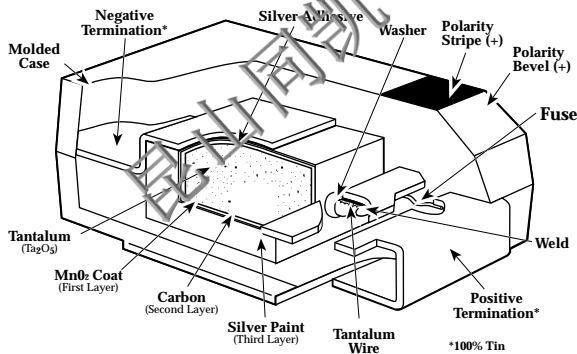

CAPACITOR MARKING

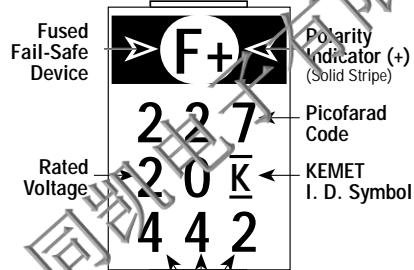

Print Week Code:

1st Digit = Year

2nd & 3rd Digits = Week

442 = The 42nd week of 2004

SOLID TANTALUM CHIP CAPACITORS

T510 SERIES—Ultra-Low ESR



FEATURES

- Ultra Low ESR < 30 mΩ
- New E/7260 Case with ESR < 19 mΩ
- Up to 4 Amps ripple current
- RoHS Compliant & Leadfree Termination (see www.kemet.com for lead transitions)
- 100% accelerated steady-state aging
- 100% Surge current test
- Precision - molded, laser-marked case
- Symmetrical compliant terminations
- Taped and reeled per EIA 481-1

OUTLINE DRAWING

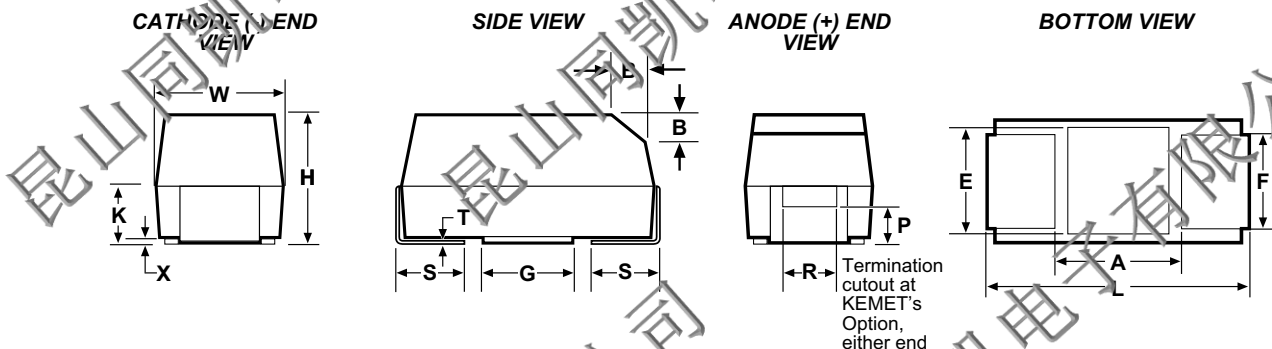

DIMENSIONS - Millimeters (Inches)

CASE SIZE		COMPONENT													
KEMET	EIA	L	W	H	$K \pm 0.20$ $(\pm .008)$	$F \pm 0.1$ $(\pm .004)$	$S \pm 0.3$ $(\pm .012)$	$B \pm 0.15$ $(\text{Ref}) \pm (.006)$	X (Ref)	P (Ref)	R (Ref)	T (Ref)	A (Min)	G (Ref)	E (Ref)
X	7343-43	7.3 ± 0.3 (.287 ± .012)	4.3 ± 0.3 (.169 ± .012)	5.0 ± 0.3 (.157 ± .012)	2.3 (.091)	2.4 (.094)	1.3 (.051)	0.5 (.020)	0.10 ± 0.10 (.004 ± .004)	0.9 (.035)	1.0 (.039)	0.13 (.005)	3.8 (.150)	3.5 (.138)	3.5 (.138)
E	7260-38	7.3 ± 0.3 (.287 ± .012)	6.0 ± 0.3 (.236 ± .012)	3.6 ± 0.2 (.142 ± .008)	2.3 (.091)	4.1 (.161)	1.3 (.051)	0.5 (.020)	0.10 ± 0.10 (.004 ± .004)	0.9 (.035)	1.0 (.039)	0.13 (.005)	3.8 (.150)	3.5 (.138)	3.5 (.138)

Notes: Metric Dimensions govern
(Ref) - Dimensions provided for reference only.

T510 RATINGS & PART NUMBER REFERENCE

Capacitance μ F	Case Size	KEMET Part Number	DC Leakage μ A @ 25°C Max	DF % @ 25°C Max	ESR mΩ @ 25°C 100 kHz Max	Ripple Current A rms @ 25°C 100 kHz, max		
						25°C	85°C	125°C
4 Volt Rating at +85°C (2.7 Volt Rating at 125°C)								
680.0	X	T510X687(1)004AS	27.2	6.0	30.0	3.0	2.7	1.2
1000.0	X	T510X108(1)004AS	40.0	6.0	18.0	3.9	3.5	1.5
1000.0	E	T510E108(1)004AS	40.0	6.0	18.0	4.0	3.6	1.6
1000.0	E	T510E108(1)004AS4115	40.0	6.0	10.0	5.3	4.8	2.1
6/6.3 Volt Rating at +85°C (4 Volt Rating at 125°C)								
470.0	X	T510X477(1)006AS	23.2	6.0	30.0	3.0	2.7	1.2
680.0	E	T510E687(1)006AS	40.8	6.0	23.0	3.5	3.2	1.4
680.0	E	T510E687(1)006AS4115	40.8	6.0	12.0	4.8	4.3	1.9
10 Volt Rating at +85°C (7 Volt Rating at 125°C)								
330.0	X	T510X337(1)010AS	33.0	6.0	35.0	2.8	2.5	1.1
25 Volt Rating at +85°C (17 Volt Rating at 125°C)								
100.0	E	T510E107(1)025AS	25.0	8.0	50.0	2.4	2.1	1.0

(1) To complete the KEMET part number, insert "K" - ±10% or "M" - ±20% capacitance tolerance.

Note: Refer to T510 Ordering Information for lead termination options.

T510 ORDERING INFORMATION

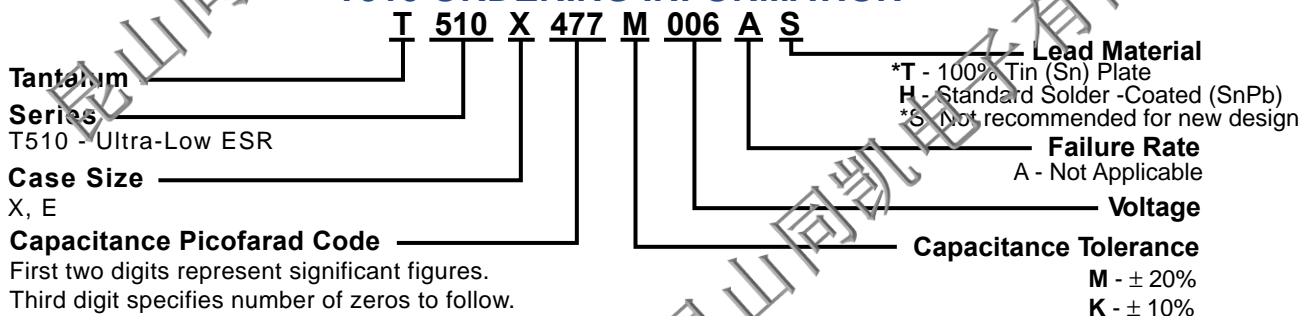

TYPICAL CAP FREQUENCY SCAN @ 25°C
T510X477M006AS

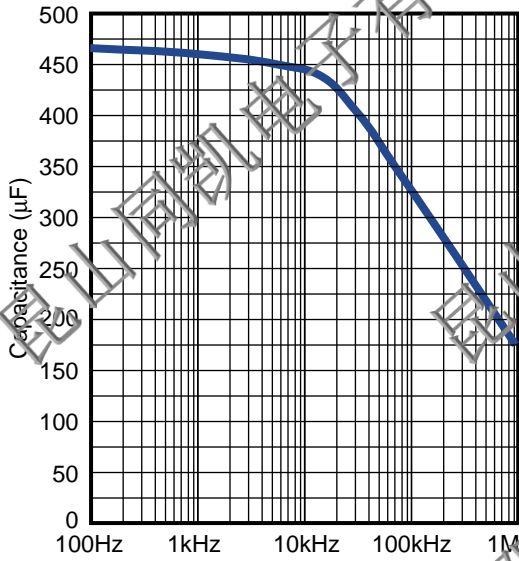

TYPICAL ESR/Z FREQUENCY SCAN @ 25°C
T510X477M006AS

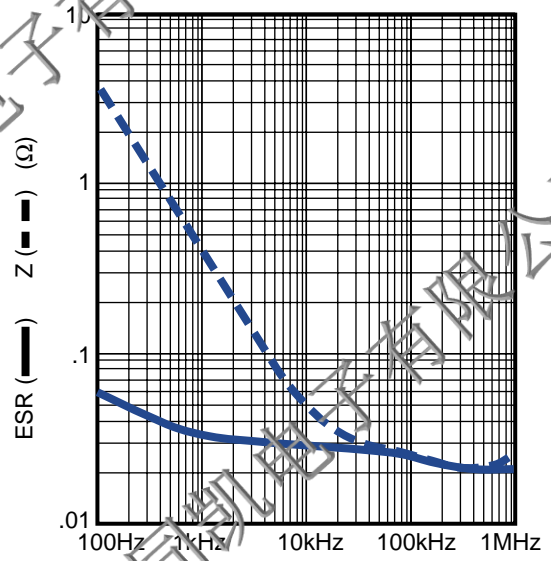

T510 CAPACITOR MARKINGS

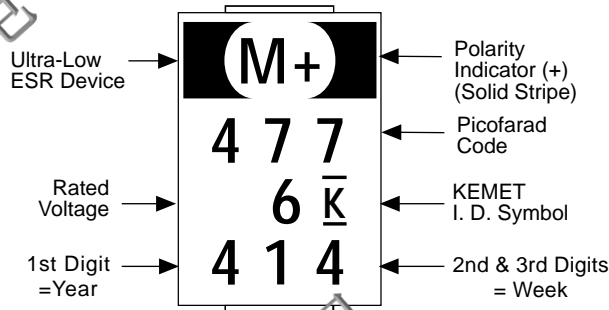

"414" = The 14th week of 2004.

T510X SERIES CONSTRUCTION

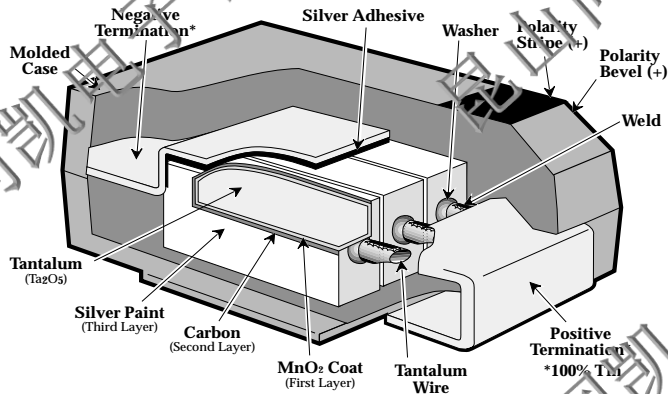

SOLID TANTALUM CHIP CAPACITORS

T510 Series - Ultra-Low ESR



TYPICAL CAP FREQUENCY SCAN @ 25°C
T510E108M004AS

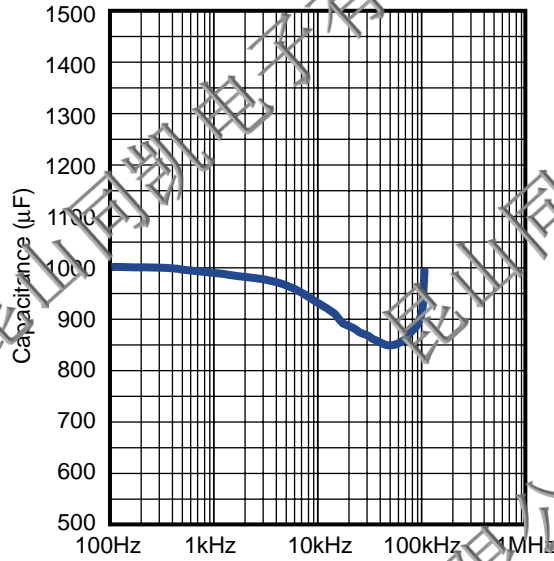

TYPICAL ESR/Z FREQUENCY SCAN @ 25°C
T510E108M004AS

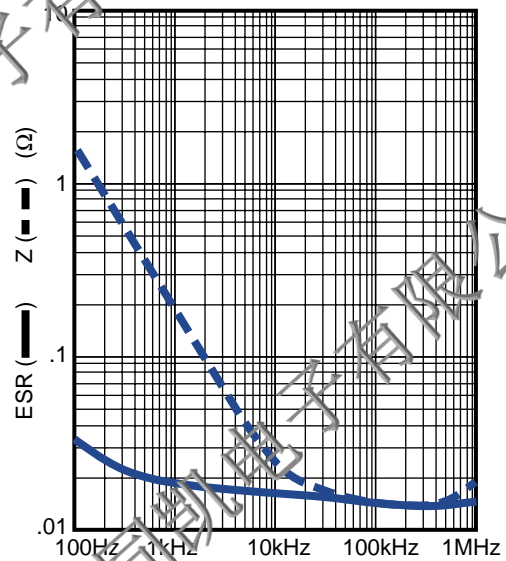

T510E CAPACITOR MARKINGS

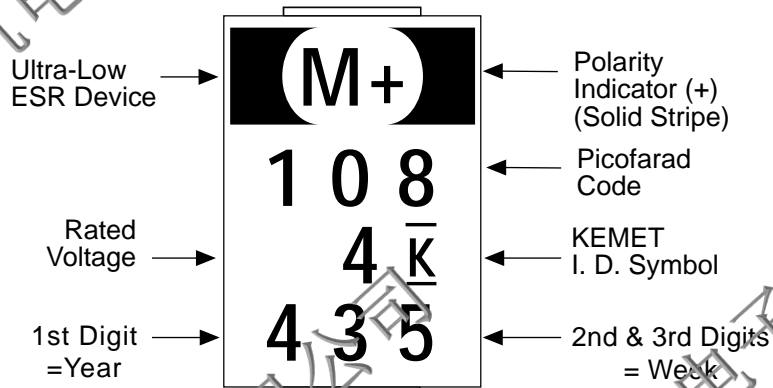

*435 = The 35th week of 2004.

T510E SERIES CONSTRUCTION

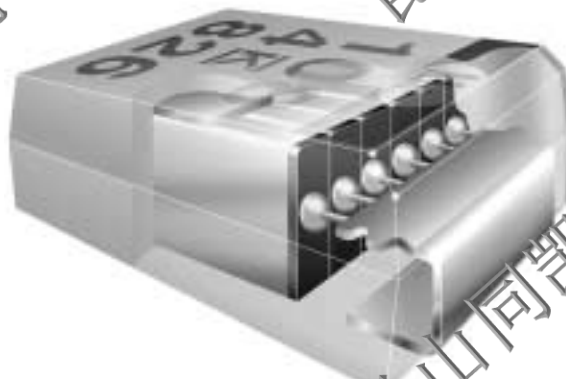

Solid Tantalum Surface Mount

COMPONENT PERFORMANCE CHARACTERISTICS

Introduction

KEMET has developed a new type of tantalum capacitor that replaces the solid manganese dioxide electrode with a solid conductive polymer. This product is named the KO-CAP for **KEMET Organic Capacitor**. The basic families are the T520, T525 and T530 series. A separate detail of performance characteristics is presented here as there are some differences between the polymer tantalums and the standard MnO₂ types. Like all KEMET tantalum chips, these series are 100% screened for all electrical parameters: Capacitance @ 120 Hz, Dissipation Factor (DF) @ 120 Hz, ESR @ 100 kHz and DC Leakage. It is also 100% surge current tested at full rated voltage through a low impedance circuit. The advantages of the polymer include very low ESR and elimination of the potentially catastrophic failure mode that may occur with standard tantalum capacitors in a high current application. Although the natural KO-CAP series failure mechanism is a short circuit, it does not exhibit an explosive failure mode.

ELECTRICAL

1. Operating Temperature Range

- -55°C to +105°C for T520; -55°C to +125°C for T525 and T530

For T525 and T530 Series above 105°C, the voltage rating is reduced linearly from 1.0 x rated voltage to 0.8 x rated voltage at 125°C.

2. Non-Operating Temperature Range

- -55°C to +105°C for T520
- -55°C to +125°C for T525 and T530

3. Capacitance and Tolerance

- 15µF to 1500µF
- ±20% Tolerance

Capacitance is measured at 120 Hz, up to 1.0 volt rms maximum and up to 2.5V DC maximum. DC bias causes only a small reduction in capacitance, up to about 2% when full rated voltage is applied. DC bias is not commonly used for room temperature measurements but is more commonly used when measuring at temperature extremes.

Capacitance does decrease with increasing frequency, but not nearly as much or as quickly as standard tantalums. Figure 1 compares the frequency induced cap roll-off between the KO-CAP and traditional MnO₂ types. Capacitance also increases with increasing temperature. See section 12 for temperature coefficients.

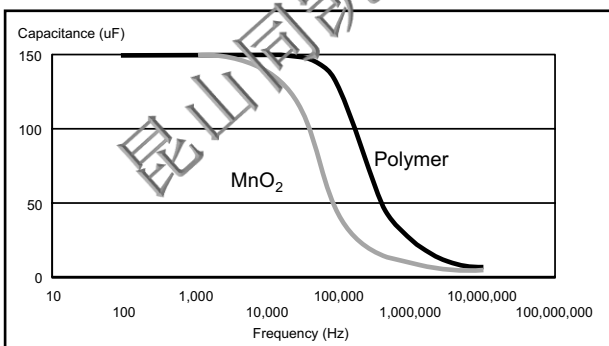

FIGURE 1

4. Voltage Ratings

• 2V-25V DC Rated Voltage

This is the maximum peak DC operating voltage from -55°C to +105°C for continuous duty. Above 105°C, this voltage is derated linearly to 2/3 rated voltage for operation at 125°C for T525 and T530 Series.

• Surge Voltage Ratings

Surge voltage capability is demonstrated by application of 1000 cycles of the relevant voltage, at 25°C, 85°C or 105°C. The parts are charged through a 33 ohm resistor for 30 seconds and then discharged through a 33 ohm resistor for 30 seconds for each cycle.

• Voltage Ratings • Table 1

Rated Voltage	Surge Voltage	Derated Voltage	Derated Surge Voltage
-55°C to +105°C		+125°C	
2V	2.6V	1.6V	2.1V
2.5V	3.3V	2.0V	2.6V
3V	3.9V	2.4V	3.1V
4V	5.2V	3.2V	4.2V
6.3V	8.2V	5V	6.5V
8V	10.4V	6.4V	8.3V
10V	13V	8V	10.4V
16V	20.8V	12.8V	16.6V
25V	32.5V	20V	26V

5. Reverse Voltage Rating & Polarity

Polymer tantalum capacitors are polar devices and may be permanently damaged or destroyed if connected in the wrong polarity. The positive terminal is identified by a laser-marked stripe and may also include a beveled edge. These capacitors will withstand a small degree of transient voltage reversal for short periods as shown in the following table. Please note that these parts may not be operated continuously in reverse, even within these limits.

Table 2

Temperature	Permissible Transient Reverse Voltage
25°C	15% of Rated Voltage
55°C	10% of Rated Voltage
85°C	5% of Rated Voltage
105°C	3% of Rated Voltage

6. DC Leakage Current

Because of the high conductivity of the polymer, the KO-CAP family has higher leakage currents than traditional MnO₂ type Tantalum caps. The DC Leakage limits at 25°C are calculated as $0.1 \times C \times V$, where C is cap in µF and V is rated voltage in Volts. Limits for all part numbers are listed in the ratings tables.

DC Leakage current is the current that flows through the capacitor dielectric after a five minute charging period at rated voltage. Leakage is measured at 25°C with full rated voltage applied to the capacitor through a 1000 ohm resistor in series with the capacitor.

COMPONENT PERFORMANCE CHARACTERISTICS

DC Leakage current does increase with temperature. The limits for 85°C @ Rated Voltage and 105°C @ 0.8 x Rated Voltage are both 10 times the 25°C limit.

7. Surge Current Capability

Certain applications may induce heavy surge currents when circuit impedance is very low (~0. ohm per volt). Driving inductance may also cause voltage ringing. Surge currents may appear as transients during turn-on of equipment.

The KO-CAP has a very high tolerance for surge current. And although the failure mechanism is a short circuit, they do not ignite as may occur with standard tantalums in such applications.

The KO-CAP series receives 100% screening for surge current in our production process. Capacitors are surged 4 times at full rated voltage applied through a total circuit resistance of <0.5 ohms. Failures are removed during subsequent electrical testing.

8. Dissipation Factor (DF)

Refer to part number tables for maximum DF limits.

Dissipation factor is measured at 120 Hz, up to 1.0 volt rms maximum, and up to 2.5 volts DC maximum at +25°C. The application of DC bias causes a small reduction in DF, about 0.2% when full rated voltage is applied. DF increases with increasing frequency.

Dissipation factor is the ratio of the equivalent series resistance (ESR) to the capacitive reactance, (X_c) and is usually expressed as a percentage. It is directly proportional to both capacitance and frequency. Dissipation factor loses its importance at higher frequencies, (above about 1 kHz), where impedance (Z) and equivalent series resistance (ESR) are the normal parameters of concern.

$$DF = \frac{R}{X_c} = 2 \pi f CR$$

DF = Dissipation Factor
 R = Equivalent Series Resistance (Ohms)
 X_c = Capacitive Reactance (Ohms)
 f = Frequency (Hertz)
 C = Series Capacitance (Farads)

DF is also referred to as tan δ or "loss tangent." The "Quality Factor," "Q," is the reciprocal of DF.

9. Equivalent Series Resistance (ESR) and Impedance (Z)

The Equivalent Series Resistance (ESR) of the KO-CAP is much lower than standard Tantalum caps because the polymer cathode has much higher conductivity. ESR is not a pure resistance, and it decreases with increasing frequency.

Total impedance of the capacitor is the vector sum of capacitive reactance (X_c) and ESR, below resonance; above resonance total impedance is the vector sum of inductive reactance (X_L) and ESR.

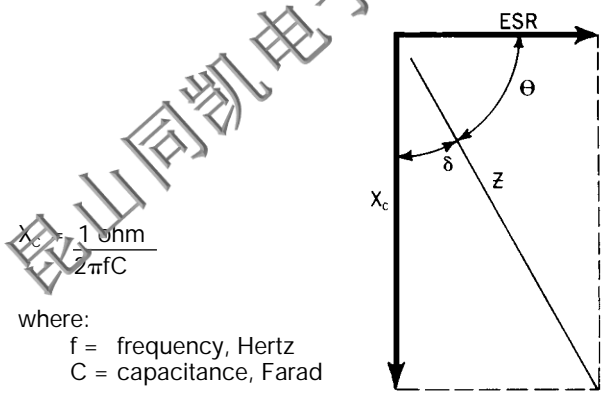

FIGURE 2a Total Impedance of the Capacitor Below Resonance

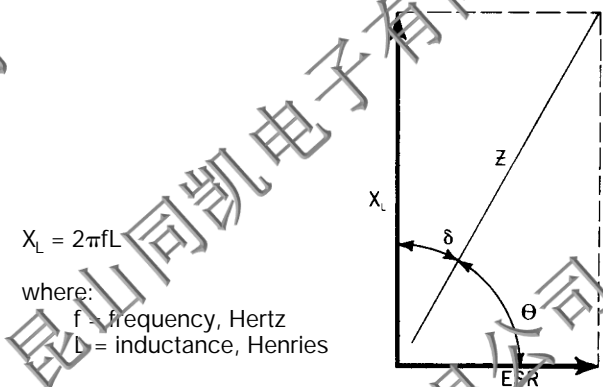

FIGURE 2b Total Impedance of the Capacitor Above Resonance

To understand the many elements of a capacitor, see Figure 3.

Polymer Tantalum Surface Mount

COMPONENT PERFORMANCE CHARACTERISTICS

ESR and Impedance

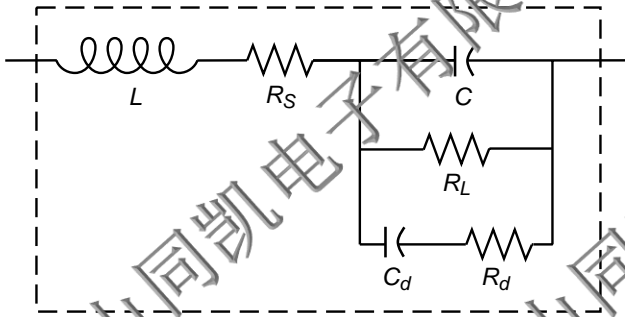

FIGURE 3 The Real Capacitor

A capacitor is a complex impedance consisting of many series and parallel elements, each adding to the complexity of the measurement system.

L — Represents lead wire and construction inductance. In most instances (especially in solid tantalum and monolithic ceramic capacitors) it is insignificant at the basic measurement frequencies of 120 and 1000 Hz.

R_s — Represents the actual ohmic series resistance in series with the capacitance. Lead wires and capacitor electrodes are contributing sources.

R_L — Capacitor Leakage Resistance. Typically it can reach 50,000 megohms in a tantalum capacitor. It can exceed 10^{12} ohms in monolithic ceramics and in film capacitors.

R_d — The dielectric loss contributed by dielectric absorption and molecular polarization. It becomes very significant in high frequency measurements and applications. Its value varies with frequency.

C_d — The inherent dielectric absorption of the solid tantalum capacitor which typically equates to 1-2% of the applied voltage.

As frequency increases, X_C continues to decrease according to its equation above. There is unavoidable inductance as well as resistance in all capacitors, and at some point in frequency, the reactance ceases to be capacitive and becomes inductive. This frequency is called the self-resonant point. In solid tantalum capacitors, the resonance is damped by the ESR, and a smooth, rather than abrupt, transition from capacitive to inductive reactance follows.

Figure 4 compares the frequency response of a KO-CAP to a standard Tantalum chip. See also frequency curves shown in the T520 section, p.46. Maximum limits for 100 kHz ESR are listed in the part number tables for each series.

The T530 Capacitance, Impedance and ESR vs. Frequency Comparisons are located on page 52. Maximum limits for 100 kHz are listed in the part number table on page 51.

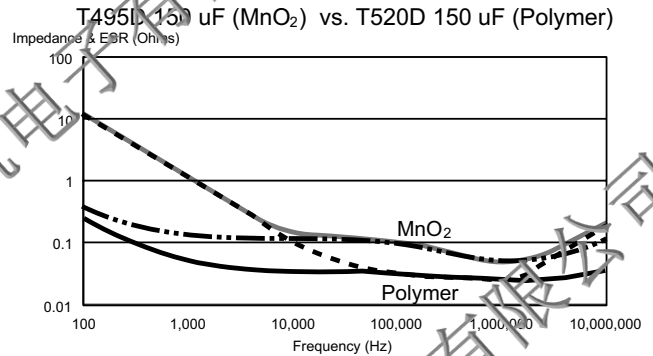

FIGURE 4

10. AC Power Dissipation

Power dissipation is a function of capacitor size and materials. Maximum power ratings have been established for all case sizes to prevent overheating. In actual use, the capacitor's ability to dissipate the heat generated at any given power level may be affected by a variety of circuit factors. These include board density, pad size, heat sinks and air circulation.

Table 3
Tantalum Chip Power Dissipation Ratings

Case Code		Maximum Power Dissipation mWatts @ +25°C w/+20°C Rise
KEMET	EIA	
T520/T	3528-12	70
T52x/B	3528-21	85
T520/V	7343-20	125
T52x/D	7343-31	150
T520/Y	7343-40	161
T520/X	7343-43	165
T530/D	7343-31	255
T530/Y	7343-40	263
T530/X	7343-43	270
T530/E	7260-38	285

11. AC Operation

Permissible AC ripple voltage and current are related to equivalent series resistance (ESR) and power dissipation capability.

Permissible AC ripple voltage which may be applied is limited by three criteria:

- The positive peak AC voltage plus the DC bias voltage, if any, must not exceed the DC voltage rating of the capacitor.
- The negative peak AC voltage, in combination with bias voltage, if any, must not exceed the permissible reverse voltage ratings presented in Section 5.
- The power dissipated in the ESR of the capacitor must not exceed the appropriate value specified in Section 10.

COMPONENT PERFORMANCE CHARACTERISTICS

Actual power dissipated may be calculated from the following:

$$P = I^2 R$$

$$\text{Substituting } I = \frac{E}{Z}, \quad P = \frac{E^2 R}{Z^2}$$

where:

I = rms ripple current (amperes)

E = rms ripple voltage (volts)

P = power (watts)

Z = impedance at specified frequency (ohms)

R = equivalent series resistance at specified frequency (ohms)

Using P max from Table 3, maximum allowable rms ripple current or voltage may be determined as follows:

$$I(\text{max}) = \sqrt{P \text{ max}/R} \quad E(\text{max}) = Z \sqrt{P \text{ max}/R}$$

These values should be derated at elevated temperatures as follows:

Temperature	Derating Factor
85°C	.9
125°C	.4

ENVIRONMENTAL

12. Temperature Stability

Mounted capacitors withstand extreme temperature testing at a succession of continuous steps at +25°C, -55°C, +25°C, +85°C, +105°C, +25°C in that order. Capacitors are allowed to stabilize at each temperature before measurement. Cap, DF, and DCL are measured at each temperature except DC Leakage is not measured at -55°C.

*Maximum temperature 125°C for T525 and T530 series.

Table 4

Acceptable limits are as follows:

Step	Temp.	ΔCap	DCL	DF
1	+25°C	Specified Tolerance	Catalog Limit	Catalog Limit
2	-55°C	±20% of initial value	N/A	Catalog Limit
3	+25°C	±10% of initial value	Catalog Limit	Catalog Limit
4	+85°C	±20% of initial value	10x Catalog Limit	1.2x Catalog Limit
5	+105°C (125°C for T525, T530)	±30% of initial value	10x Catalog Limit	1.5x Catalog Limit
6	+25°C	±10% of initial value	Catalog Limit	Catalog Limit

13. Standard Life Test

• 85°C, Rated Voltage, 2000 Hours

Post Test Performance:

- Capacitance: within -20%/+10% of initial value
- DF: within initial limit
- DC Leakage: within initial limit
- ESR: within initial limit

14. High Temperature Life Test

• 105°C, 0.8 x Rated Voltage, 2000 hours, 125°C for T525, T530 Series

Post Test Performance:

- Capacitance: within -20%/+10% of initial value
- DF: within initial limit
- DC Leakage: within 1.25 initial limits for T520; 2 x initial limit for T525, T530
- ESR: within 2 x initial limit for T520, T530
ESR: within initial limit for T525

15. Storage Life Test

• 105°C, 0VDC, 2000 Hours for T520, 125°C for T525, T530

Post Test Performance:

- Capacitance: within -20%/+10% of initial value
- DF: within initial limit
- DC Leakage: within 1.25 initial limits for T520; 2 x initial limit for T525, T530
- ESR: within 2 x initial limit for T520, T530
ESR: within initial limit for T525

16. Thermal Shock

• Mil-Std-202, Method 107, Condition B

Minimum temperature is -55°C

Maximum temperature is +105°C for T520; 125°C for T525, T530

500 Cycles

Post Test Performance:

- Capacitance: within +10%/-20% of initial value
- DF: within initial limit
- DC Leakage: within initial limit
- ESR: within 2 x initial limit

17. Moisture Resistance Testing

• J-Std-020

Steps 7a and 7b excluded, 0V, 21 cycles

Post Test Performance:

- Capacitance: within ±30% of initial value
- DF: within initial limit
- DC Leakage: within initial limit
- ESR: within initial limit
- Meets MSL Level 3

18. Load Humidity

• 85°C, 85% RH, Rated Voltage, 500 Hours

Post Test Performance:

- Capacitance: within +35%/-5% of initial value
- DF: within initial limit
- DC Leakage: within 5 x initial limit
- ESR: within 2 x initial limit

19. ESD

• Polymer tantalum capacitors are not sensitive to Electro-Static Discharge (ESD).

20. Failure Mechanism and Reliability

The normal failure mechanism is dielectric breakdown. Dielectric failure can result in high DC Leakage current and may proceed to the level of a short circuit. With sufficient time to charge, healing may occur by one of two potential mechanisms. The polymer adjacent to the dielectric fault site may overheat and vaporize, disconnecting the fault site from the circuit. The polymer may also

COMPONENT PERFORMANCE CHARACTERISTICS

oxidize into a more resistive material that eliminates the defect site in the dielectric and reduces the flow of current.

Capacitor failure may be induced by exceeding the rated conditions of forward DC voltage, reverse DC voltage, surge current, power dissipation or temperature. Excessive environmental stress, such as prolonged or high temperature reflow processes may also trigger dielectric failure.

Failure rates may be improved in application by derating the voltage applied to the capacitor. KEMET recommends that KO-CAPS be derated to 90% or less of the rated voltage in application for part types $\leq 10V$. Parts $> 10V$ should be derated to 80% or less of the rated voltage.

KO-CAPS exhibit a benign failure mode in that they do not fail catastrophically even under typical fault conditions. If a shorted capacitor is allowed to pass unlimited current, it may overheat and the case may discolor. But this is distinctly different from the "ignition" that may occur with standard MnO₂ cathode tantalums. Replacement of the MnO₂ by the polymer removes the oxygen that fuels ignition during a failure event.

MECHANICAL

21. Resistance to Solvents

- *Mil-Std-202, Method 215*

Post Test Performance:

- Capacitance — within $\pm 10\%$ of initial value
- DC Leakage — within initial limit
- Dissipation Factor — within initial limit
- ESR — within initial limit
- Physical — no degradation of case, terminals or marking

22. Fungus

- *Mil-Std-810, Method 508*

23. Flammability

- *UL94 VO Classification*

Encapsulant materials meet this classification

24. Resistance to Soldering Heat

- *Maximum Reflow*
+240 $\pm 5^\circ C$, 10 seconds
- *Typical Reflow*
+230 $\pm 5^\circ C$, 30 seconds

Post Test Performance:

- Capacitance — within $\pm 10\%$ of initial value
- DC Leakage — within initial limit
- Dissipation Factor — within initial limit
- ESR — within initial limit

25. Solderability

- *Mil-Std-202, Method 208*
- *ANSI/J-STD-002, Test B*

Applies to Solder Coated terminations only.

26. Vibration

- *Mil-Std-202, Method 204, Condition D, 10 Hz to 2,000 Hz, 20G Peak*

Post Test Performance:

- Capacitance — within $\pm 10\%$ of initial value
- DC Leakage — within initial limit
- Dissipation Factor — within initial limit
- ESR — within initial limit

27. Shock

- *Mil-Std-202, Method 213, Condition I, 100 G Peak*

Post Test Performance:

- Capacitance — within $\pm 10\%$ of initial value
- DC Leakage — within initial limit
- Dissipation Factor — within initial limit
- ESR - within initial limit

28. Terminal Strength

- **Pull Force**
• **One Pound (454 grams), 30 Seconds**

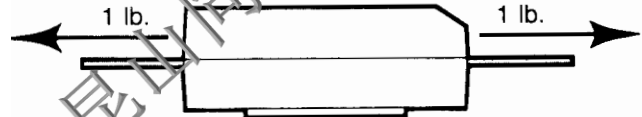

- **Tensile Force**
• **Four Pounds (1.8 kilograms), 60 Seconds**

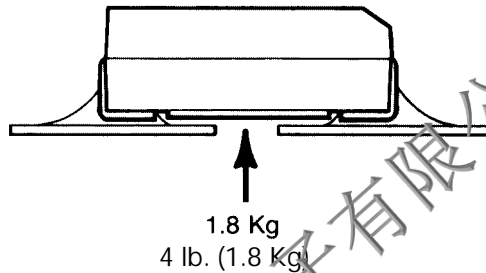

- **Shear Force**
Table 5 Maximum Shear Loads

Case Code		Maximum Shear Loads	
KEMET	EIA	Kilograms	Pounds
T	3528-12	3.6	8.0
B	3528-21	3.6	8.0
V	7343-20	5.0	11.0
D	7343-31	5.0	11.0
Y	7343-40	5.0	11.0
X	7343-43	5.0	11.0

Post Test Performance:

- Capacitance — within $\pm 5\%$ of initial value
- DC Leakage — within initial limit
- Dissipation Factor — within initial limit
- ESR - within initial limit

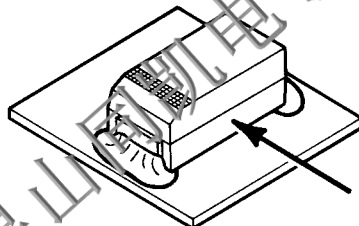

COMPONENT PERFORMANCE CHARACTERISTICS

APPLICATIONS

29. Handling

Automatic handling of encapsulated components is enhanced by the molded case which provides compatibility with all types of high speed pick and place equipment. Manual handling of these devices presents no unique problems. Care should be taken with your fingers, however, to avoid touching the solder-coated terminations as body oils, acids and salts will degrade the solderability of these terminations. Finger cots should be used whenever manually handling all solderable surfaces.

30. Termination Coating

After May 1, 2004, the standard finish coating for T520, T525 and T530 is transitioning to 100% tin.

31. Recommended Mounting Pad Geometries

Proper mounting pad geometries are essential for successful solder connections. These dimensions are highly process sensitive and should be designed to maximize the intergrity of the solder joint, and to minimize component rework due to unacceptable solder joints.

Figure 5 illustrates pad geometry. The table provides recommended pad dimensions for reflow soldering techniques. These dimensions are intended to be a starting point for circuit board designers, to be fine tuned, if necessary, based upon the peculiarities of the soldering process and/or circuit board design.

Contact KEMET for Engineering Bulletin Number F-2100 entitled "Surface Mount Mounting Pad Dimensions and Considerations" for further details on this subject.

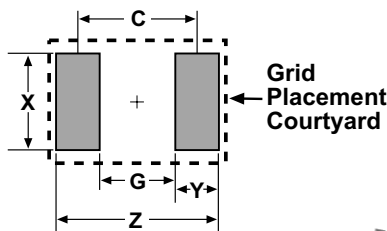

Figure 5

Table 6 - Land Pattern Dimensions for Reflow Solder

KEMET/EIA Size Code	Pad Dimensions				
	Z	G	X	Y (ref)	C (ref)
B/3528-21, T/3528-12	5.00	1.10	2.50	1.95	3.05
D/7343-31, V/7343-20	8.90	3.80	2.70	2.55	6.35
X/7343-43, Y/7343-40					

32. Soldering

The T52X KO-CAP family has been designed for reflow solder processes. Solder-coated terminations have excellent wetting characteristics for high integrity solder fillets. Preheating of these components is recommended to avoid extreme thermal stress. The maximum recommended preheat rate is 2°C per second. See page 14 for SnPb soldering profile.

Hand soldering should be avoided. If necessary, it should be performed with care due to the difficulty in process control. Care should be taken to avoid contact of the soldering iron to the molded case. The iron should be used to heat the solder pad, applying solder between the pad and the termination, until reflow occurs. The iron should be removed. "Wiping" the edges of a chip and heating the top surface is not recommended.

During typical reflow operations a slight darkening of the gold-colored epoxy may be observed. This slight darkening is normal and is not harmful to the product. Marking permanency is not affected by this change.

33. Washing

Standard washing techniques and solvents are compatible with all KEMET surface mount tantalum capacitors. Solvents such as Freon TMC and TMS, Trichlorethane, methylene chloride, prelete, and isopropyl alcohol are not harmful to these components. Please note that we are not endorsing the use of banned or restricted solvents. We are simply stating that they would not be harmful to the components.

Ultrasonic agitation is utilized in the cleaning process, care should be taken to minimize energy levels and exposure times to avoid damage to the terminations.

KEMET tantalum chips are also compatible with newer aqueous and semi-aqueous processes.

34. Encapsulations

Under normal circumstances, potting or encapsulation of KEMET tantalum chips is not required.

35. Storage Environment

Tantalum polymer series (T520, T525, T530) are shipped in moisture barrier bags with a desiccant and moisture indicator card. These series are classified as MSL (Moisture Sensitivity Level 3). Upon opening the moisture barrier bag, parts should be mounted within 7 days to prevent moisture absorption and outgassing. If the 7 day window is exceeded, the parts can be baked per the instructions on the bag (168 hours at 40±5°C).

Tantalum chip capacitors should be stored in normal working environments. While the chips themselves are quite robust in other environments, solderability will be degraded by exposure to high temperatures, high humidity, corrosive atmospheres, and long term storage. In addition, packaging materials will be degraded by high temperature - reels may soften or warp, and tape peel force may increase. KEMET recommends that maximum storage temperature not exceed 40 degrees C, and the maximum storage humidity not exceed 60% relative humidity. In addition, temperature fluctuations should be minimized to avoid condensation on the parts, and atmospheres should be free of chlorine and sulfur bearing compounds. For optimized solderability, chip stock should be used promptly, preferably within 1.5 years of receipt.

FEATURES

- Polymer Cathode Technology
- Low ESR
- High Frequency Cap Retention
- No-Ignition Failure Mode
- Use Up to 90% of Rated Voltage (10% Derating) for part types ≤ 10 Volts
- Halogen Free Epoxy
- 100% Accelerated Steady State Aging
- Volumetrically Efficient
- Use Up to 80% of Rated Voltage (20% Derating) for part types > 10 Volts
- Capacitance 15 to 1000 μ F ($\pm 20\%$)
- Voltage 2V to 25V
- EIA Standard Case Sizes
- 100% Surge Current Tested
- Operating Temperature -55°C to +105°C
- Self Healing Mechanism
- RoHS Compliant & Leadfree Terminations (see www.kemet.com for lead transition)

OUTLINE DRAWING

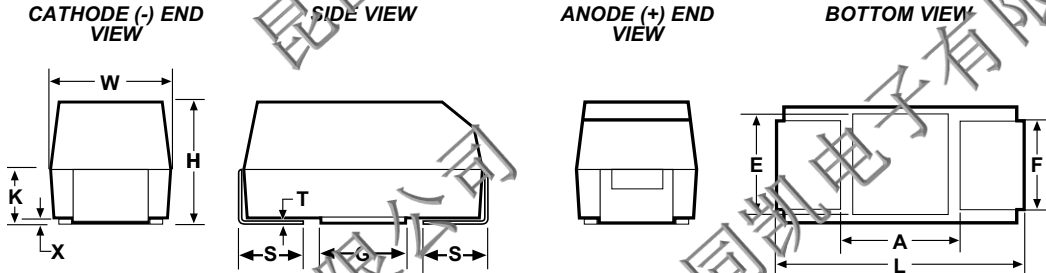

DIMENSIONS - MILLIMETERS

Case Size		L	W	H	K ± 0.20	F ± 0.1	S ± 0.3	X(Ref)	T(Ref)	A(Min)	G(ref)	E(ref)
KEMET	EIA											
A	3216-18	3.2 ± 0.2	1.6 ± 0.2	1.6 ± 0.2	0.9	1.2	0.8	0.10 ± 0.10	0.13	0.8	1.1	1.3
T	3528-12	3.5 ± 0.2	2.8 ± 0.2	1.2 max	0.3	2.2	0.8	0.05	0.13	1.1	1.8	2.2
B	3528-21	3.5 ± 0.2	2.8 ± 0.2	1.9 ± 0.2	0.9	2.2	0.8	0.10 ± 0.10	0.13	1.1	1.8	2.2
C	6032-28	6.0 ± 0.3	3.2 ± 0.3	2.5 ± 0.3	1.4	2.2	1.3	0.10 ± 0.10	0.13	2.5	2.8	2.4
W	7343-15	7.3 ± 0.3	4.3 ± 0.3	1.5 max	0.6	2.4	1.3	0.05	0.13	3.8	3.5	3.5
V	7343-20	7.3 ± 0.3	4.3 ± 0.3	1.9 max	0.9	2.4	1.3	0.05	0.13	3.8	3.5	3.5
D	7343-31	7.3 ± 0.3	4.3 ± 0.3	2.8 ± 0.3	1.5	2.4	1.3	0.10 ± 0.10	0.13	3.8	3.5	3.5
Y	7343-40	7.3 ± 0.3	4.3 ± 0.3	4.0 max	1.9	2.4	1.3	0.10 ± 0.10	0.13	3.8	3.5	3.5
X	7343-43	7.3 ± 0.3	4.3 ± 0.3	4.0 ± 0.3	2.3	2.4	1.3	0.10 ± 0.10	0.13	3.8	3.5	3.5

T520 ORDERING INFORMATION

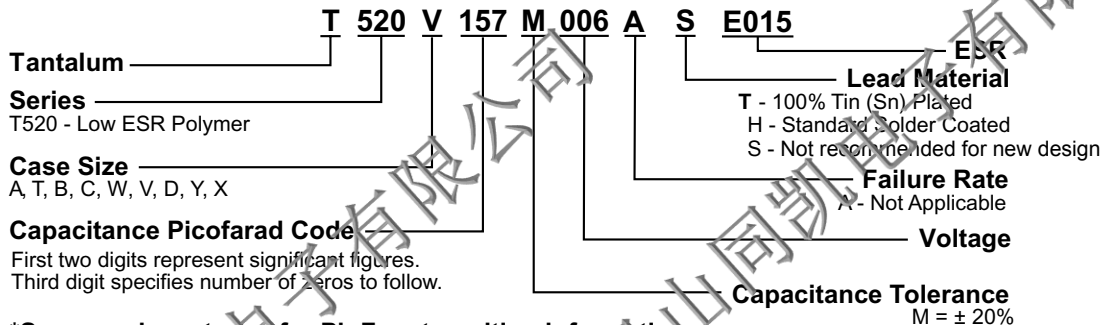

COMPONENT MARKING

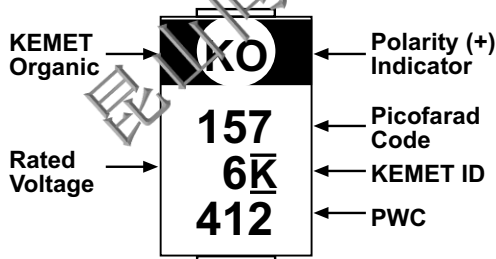

412 = 12th week of 2004

T520 SERIES CONSTRUCTION

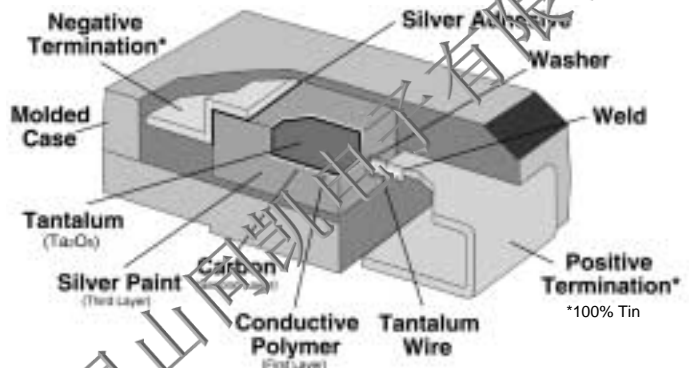

POLYMER TANTALUM CHIP CAPACITORS

T520 Series - KO Cap



T520 RATINGS & PART NUMBER REFERENCE

Capacitance [pF]	Case Size	KEMET Part Number	DC Leakage μ A @ 25°C Max	DF% @ 25°C 120 Hz Max	ESR m Ω @ 25°C 100 kHz Max	Ripple Current Arms @ 100 kHz Max	
						w/ΔT=20°C @ -55°C to 85°C	w/ΔT= 2°C @ 105°C
2 Volt Rating @ 105°C							
470.0	V	T520V477M002A(1)E040	94	10	40	1.8	0.6
2.5 Volt Rating @ 105°C							
47.0	A	T520A476M2R5A(1)E090	12	8	90	0.9	0.3
56.0	T	T520T566M2R5A(1)E070	14	8	70	1.0	0.3
68.0	A	T520A686M2R5A(1)E070	17	8	70	1.0	0.3
68.0	A	T520A686M2R5A(1)E080	17	8	80	1.0	0.3
100.0	T	T520T107M2R5A(1)E070	25	8	70	1.0	0.3
100.0	B	T520B107M2R5A(1)E040	25	8	40	1.5	0.5
100.0	B	T520B107M2R5A(1)E070	25	8	70	1.1	0.3
220.0	B	T520B227M2R5A(1)E040	55	8	30	137.0	0.5
220.0	B	T520B227M2R5A(1)E030	55	8	35	1.6	0.5
220.0	B	T520B227M2R5A(1)E070	55	8	70	1.1	0.3
220.0	V	T520V227M2R5A(1)E107	55	10	7	4.2	1.3
220.0	V	T520V227M2R5A(1)E009	55	10	9	3.7	1.2
220.0	V	T520V227M2R5A(1)E012	55	10	12	3.2	1.0
220.0	V	T520V227M2R5A(1)E015	55	10	15	2.9	0.9
220.0	V	T520V227M2R5A(1)E025	55	10	25	2.2	0.7
220.0	V	T520V227M2R5A(1)E045	55	10	45	1.7	0.5
330.0	B	T520B337M2R5A(1)E045	83	8	45	1.4	0.4
330.0	B	T520B337M2R5A(1)E070	83	8	70	1.1	0.3
330.0	C	T520C337M2R5A(1)E025	83	8	25	2.1	0.7
330.0	C	T520C337M2R5A(1)E045	83	8	45	1.6	0.5
330.0	V	T520V337M2R5A(1)E007	83	10	7	4.2	1.3
330.0	V	T520V337M2R5A(1)E009	83	10	9	3.7	1.2
330.0	V	T520V337M2R5A(1)E015	83	10	15	2.9	0.9
330.0	V	T520V337M2R5A(1)E025	83	10	25	2.2	0.7
330.0	D	T520D337M2R5A(1)E007	83	10	7	4.6	1.5
470.0	V	T520V477M2R5A(1)E009	118	10	9	3.7	1.2
470.0	V	T520V477M2R5A(1)E012	118	10	12	3.2	1.0
470.0	V	T520V477M2R5A(1)E015	118	10	15	2.9	0.9
470.0	D	T520D477M2R5A(1)E009	118	10	9	4.1	1.3
680.0	D	T520D687M2R5A(1)E010	170	10	10	3.5	1.2
680.0	D	T520D687M2R5A(1)E015	170	10	15	3.2	1.0
680.0	D	T520D687M2R5A(1)E040	170	10	40	1.9	0.6
680.0	Y	T520Y687M2R5A(1)E015	170	10	15	3.3	1.0
680.0	Y	T520Y687M2R5A(1)E025	170	10	25	2.5	0.8
1000.0	Y	T520Y108M2R5A(1)E010	250	10	10	4.0	1.3
1000.0	Y	T520Y108M2R5A(1)E015	250	10	15	3.3	1.0
1000.0	Y	T520Y108M2R5A(1)E025	250	10	25	2.5	0.8
1000.0	X	T520X108M2R5A(1)E010	250	10	10	4.1	1.3
3 Volt Rating @ 105°C							
100.0	B	T520B107M003A(1)E040	30	8	40	1.5	0.5
100.0	B	T520B107M003A(1)E070	30	8	70	1.1	0.3
150.0	B	T520B157M003A(1)E040	45	8	40	1.5	0.5
150.0	B	T520B157M003A(1)E070	45	8	70	1.1	0.3
330.0	V	T520V337M003A(1)E009	99	10	9	3.7	1.2
330.0	V	T520V337M003A(1)E012	99	10	12	3.2	1.0
330.0	V	T520V337M003A(1)E015	99	10	15	2.9	0.9
330.0	V	T520V337M003A(1)E025	99	10	25	2.2	0.7
680.0	D	T520D687M003A(1)E015	204	10	15	3.2	1.0
680.0	D	T520D687M003A(1)E040	204	10	40	1.9	0.6
1000.0	X	T520X108M003A(1)E015	300	10	15	3.3	1.0
1000.0	X	T520X108M003A(1)E030	300	10	30	2.3	0.7
4 Volt Rating @ 105°C							
15.0	T	T520T156M004A(1)E100	6	8	100	0.8	0.3
33.0	A	T520A336M004A(1)E070	13	8	70	1.0	0.3
33.0	A	T520A336M004A(1)E080	13	8	80	1.0	0.3
47.0	A	T520A476M004A(1)E070	19	8	70	1.0	0.3
47.0	A	T520A476M004A(1)E080	19	8	80	1.0	0.3
47.0	T	T520T476M004A(1)E070	19	8	70	1.0	0.3
68.0	T	T520T686M004A(1)E070	27	8	70	1.0	0.3
68.0	B	T520B686M004A(1)E040	27	8	40	1.5	0.5
68.0	B	T520B686M004A(1)E070	27	8	70	1.1	0.3
100.0	B	T520B107M004A(1)E035	40	8	35	1.6	0.5
100.0	B	T520B107M004A(1)E040	40	8	40	1.5	0.5
100.0	B	T520B107M004A(1)E070	40	8	70	1.1	0.3
150.0	B	T520B157M004A(1)E030	60	8	30	1.7	0.5
150.0	B	T520B157M004A(1)E015	60	8	35	1.6	0.5
150.0	B	T520B157M004A(1)E040	60	8	40	1.5	0.5
150.0	B	T520B157M004A(1)E070	60	8	70	1.1	0.3
150.0	C	T520C157M004A(1)E045	60	8	45	1.6	0.5
150.0	V	T520V157M004A(1)E007	60	10	7	4.2	1.3
150.0	V	T520V157M004A(1)E009	60	10	9	3.7	1.2
150.0	V	T520V157M004A(1)E012	60	10	12	3.2	1.0
150.0	V	T520V157M004A(1)E015	60	10	15	2.9	0.9
150.0	V	T520V157M004A(1)E025	60	10	25	2.2	0.7
220.0	B	T520B227M004A(1)E045	88	8	45	1.4	0.4
220.0	B	T520B227M004A(1)E070	88	8	70	1.1	0.3
220.0	C	T520C227M004A(1)E025	88	8	25	2.1	0.7
220.0	C	T520C227M004A(1)E045	88	8	45	1.6	0.5
220.0	V	T520V227M004A(1)E007	88	10	7	4.2	1.3
220.0	V	T520V227M004A(1)E009	88	10	9	3.7	1.2
220.0	V	T520V227M004A(1)E012	88	10	12	3.2	1.0
220.0	V	T520V227M004A(1)E015	88	10	15	2.9	0.9
220.0	V	T520V227M004A(1)E025	88	10	25	2.2	0.7
220.0	V	T520V227M004A(1)E040	88	10	40	1.8	0.6
220.0	V	T520V227M004A(1)E045	88	10	45	1.7	0.5
220.0	D	T520D227M004A(1)E012	88	10	12	3.5	1.1
220.0	D	T520D227M004A(1)E065	88	10	65	1.5	0.5
330.0	V	T520V337M004A(1)E009	132	10	9	3.7	1.2
330.0	V	T520V337M004A(1)E012	132	10	12	3.2	1.0
330.0	V	T520V337M004A(1)E025	132	10	25	2.2	0.7
330.0	V	T520V337M004A(1)E040	132	10	40	1.8	0.6
330.0	D	T520D337M004A(1)E009	132	10	9	4.1	1.3
330.0	D	T520D337M004A(1)E015	132	10	15	3.2	1.0
330.0	D	T520D337M004A(1)E040	132	10	40	1.9	0.6
330.0	D	T520D337M004A(1)E045	132	10	45	1.8	0.6
470.0	D	T520D477M004A(1)E010	188	10	10	3.5	1.1
470.0	D	T520D477M004A(1)E012	188	10	12	3.5	1.1
470.0	D	T520D477M004A(1)E015	188	10	15	3.3	1.0
470.0	D	T520D477M004A(1)E018	188	10	18	2.9	0.9
470.0	D	T520D477M004A(1)E025	188	10	25	2.4	0.8
470.0	D	T520D477M004A(1)E040	188	10	40	1.9	0.6
680.0	D	T520D687M004A(1)E025	272	10	25	2.4	0.8
680.0	Y	T520Y687M004A(1)E010	272	10	10	4.0	1.3
680.0	Y	T520Y687M004A(1)E015	272	10	15	3.3	1.0
680.0	Y	T520Y687M004A(1)E025	272	10	25	2.5	0.8
680.0	X	T520X687M004A(1)E010	272	10	10	4.1	1.3
680.0	X	T520X687M004A(1)E015	272	10	15	3.3	1.0
680.0	X	T520X687M004A(1)E035	272	10	35	2.2	0.7

(1) To complete the KEMET part number, insert the lead material designator as shown on page 46.

T520 RATINGS & PART NUMBER REFERENCE

Capacitance µF	Case Size	KEMET Part Number	DC Leakage µA @ 25°C Max	DF% @ 25°C 100 Hz Max	ESR mΩ @ 25°C 100 kHz Max	Ripple Current Arms @ 100 kHz Max	
						w/ΔT=20°C @ -55°C to 85°C	w/ΔT= 2°C @ 105°C
6.3 Volt Rating @ 105°C							
15.0	T	T520T156M006A(1)E100	25	8	100	0.8	0.3
22.0	A	T520A226M006A(1)E090	14	8	90	0.9	0.3
22.0	A	T520A226M006A(1)E100	14	8	100	0.9	0.3
33.0	A	T520A336M006A(1)E070	21	8	70	1.0	0.3
33.0	A	T520A336M006A(1)E085	21	8	80	1.0	0.3
33.0	T	T520T336M006A(1)E070	21	8	70	0.9	0.4
33.0	B	T520B336M006A(1)E040	21	8	40	1.5	0.5
33.0	B	T520B336M006A(1)E070	21	8	70	1.1	0.3
47.0	T	T520T476M006A(1)E070	30	8	70	1.0	0.3
47.0	B	T520B476M006A(1)E040	30	8	40	1.5	0.5
47.0	B	T520B476M006A(1)E070	30	8	70	1.1	0.3
68.0	B	T520B68M006A(1)E040	43	8	40	1.5	0.5
68.0	B	T520B68M006A(1)E070	43	8	70	1.1	0.3
100.0	B	T520B107M006A(1)E040	63	8	40	1.5	0.5
100.0	B	T520B107M006A(1)E070	63	8	70	1.1	0.3
100.0	W	T520W107M006A(1)E040	63	10	40	1.7	0.5
100.0	V	T520V107M006A(1)E007	63	10	7	4.2	1.3
100.0	V	T520V107M006A(1)E009	63	10	9	3.7	1.2
100.0	V	T520V107M006A(1)E012	63	10	12	3.2	1.0
150.0	B	T520B157M006A(1)E045	95	8	45	1.4	0.4
150.0	B	T520B157M006A(1)E070	95	8	70	1.1	0.3
150.0	C	T520C157M006A(1)E025	95	8	25	2.1	0.7
150.0	C	T520C157M006A(1)E045	95	8	45	1.6	0.5
150.0	W	T520W157M006A(1)E040	95	10	40	1.7	0.5
150.0	V	T520V157M006A(1)E007	95	10	7	4.2	1.3
150.0	V	T520V157M006A(1)E009	95	10	9	3.7	1.2
150.0	V	T520V157M006A(1)E012	95	10	12	3.2	1.0
150.0	V	T520V157M006A(1)E015	95	10	15	2.9	0.9
150.0	V	T520V157M006A(1)E025	95	10	25	2.2	0.7
150.0	V	T520V157M006A(1)E040	95	10	40	1.7	0.5
150.0	V	T520V157M006A(1)E045	95	10	45	1.6	0.5
150.0	D	T520D157M006A(1)E015	95	10	15	3.2	1.0
150.0	D	T520D157M006A(1)E025	95	10	25	2.4	0.8
150.0	D	T520D157M006A(1)E055	95	10	55	1.7	0.5
220.0	V	T520V227M006A(1)E009	139	10	9	3.7	1.2
220.0	V	T520V227M006A(1)E012	139	10	12	3.2	1.0
220.0	V	T520V227M006A(1)E015	139	10	15	2.9	0.9
220.0	V	T520V227M006A(1)E025	139	10	25	2.2	0.7
220.0	V	T520V227M006A(1)E040	139	10	40	1.8	0.6
220.0	D	T520D227M006A(1)E009	139	10	9	4.1	1.3
220.0	D	T520D227M006A(1)E015	139	10	15	3.2	1.0
220.0	D	T520D227M006A(1)E040	139	10	40	1.9	0.6
220.0	D	T520D227M006A(1)E050	139	10	50	1.7	0.5
6.3 Volt Rating @ 105°C							
330.0	V	T520V337M006A(1)E025	208	10	25	2.2	0.7
330.0	V	T520V337M006A(1)E040	208	10	40	1.8	0.6
330.0	D	T520D337M006A(1)E010	208	10	10	3.9	1.2
330.0	D	T520D337M006A(1)E015	208	10	15	3.2	1.0
330.0	D	T520D337M006A(1)E025	208	10	25	2.4	0.8
330.0	D	T520D337M006A(1)E040	208	10	40	1.9	0.6
330.0	D	T520D337M006A(1)E045	208	10	45	1.8	0.6
330.0	Y	T520Y337M006A(1)E015	208	10	15	3.3	1.0
330.0	Y	T520Y337M006A(1)E025	208	10	25	2.5	0.8
470.0	Y	T520Y477M006A(1)E010	296	10	10	4.0	1.3
470.0	Y	T520Y477M006A(1)E015	296	10	15	3.3	1.0
470.0	Y	T520Y477M006A(1)E018	296	10	18	3.0	0.9
470.0	Y	T520Y477M006A(1)E025	296	10	25	2.5	0.8
470.0	X	T520X477M006A(1)E010	296	10	10	4.1	1.3
470.0	X	T520X477M006A(1)E018	296	10	18	3.0	1.0
470.0	X	T520X477M006A(1)E035	296	10	35	2.2	0.7
470.0	X	T520X477M006A(1)E040	296	10	40	2.0	0.6
8 Volt Rating @ 105°C							
33.0	B	T520B336M008A(1)E040	26	8	40	1.5	0.5
33.0	B	T520B336M008A(1)E070	26	8	70	1.1	0.3
150.0	D	T520D157M008A(1)E025	120	10	25	2.4	0.8
150.0	D	T520D157M008A(1)E040	120	10	40	1.9	0.6
150.0	D	T520D157M008A(1)E055	120	10	55	1.7	0.5
10 Volt Rating @ 105°C							
33.0	B	T520B336M010A(1)E040	33	8	40	1.6	0.5
33.0	B	T520B336M010A(1)E070	33	8	70	1.1	0.3
68.0	V	T520V68M010A(1)E045	68	10	45	1.7	0.5
68.0	V	T520V68M010A(1)E060	68	10	60	1.4	0.5
100.0	V	T520V107M010A(1)E018	100	10	18	2.6	0.8
100.0	V	T520V107M010A(1)E025	100	10	25	2.2	0.7
100.0	V	T520V107M010A(1)E045	100	10	45	1.7	0.5
100.0	V	T520V107M010A(1)E050	100	10	50	1.6	0.5
100.0	D	T520D107M010A(1)E018	100	10	18	2.9	0.9
100.0	D	T520D107M010A(1)E055	100	10	55	1.7	0.5
100.0	D	T520D107M010A(1)E080	100	10	80	1.4	0.4
150.0	D	T520D157M010A(1)E025	150	10	25	2.4	0.8
150.0	D	T520D157M010A(1)E040	150	10	40	1.9	0.6
150.0	D	T520D157M010A(1)E055	150	10	55	1.7	0.5
220.0	D	T520D227M010A(1)E018	220	10	18	2.9	0.9
220.0	D	T520D227M010A(1)E025	220	10	25	2.4	0.8
220.0	D	T520D227M010A(1)E040	220	10	40	1.9	0.6
330.0	Y	T520Y337M010A(1)015	330	10	15	3.3	1.0
330.0	X	T520X337M010A(1)E025	330	10	25	2.6	0.8
330.0	X	T520X337M010A(1)E040	330	10	40	2.0	0.6
16 Volt Rating @ 105°C							
33.0	W	T520W336M016A(1)E045	53	10	60	1.6	0.5
33.0	V	T520V336M016A(1)E045	53	10	45	1.7	0.5
33.0	V	T520V336M016A(1)E060	53	10	60	1.4	0.5
47.0	W	T520W476M016A(1)E045	75	10	45	1.6	0.5
47.0	V	T520V476M016A(1)E045	75	10	45	1.7	0.5
47.0	V	T520V476M016A(1)E070	76	10	70	1.3	0.4
47.0	D	T520D476M016A(1)E035	75	10	35	3.3	0.9
47.0	D	T520D476M016A(1)E070	75	10	70	1.5	0.5
20 Volt Rating @ 105°C							
22.0	V	T520V226M020A(1)E040	44	10	40	1.8	0.6
22.0	V	T520V226M020A(1)E090	44	10	90	1.2	0.4
25 Volt Rating @ 105°C							
15.0	V	T520V156M025A(1)E090	38	10	90	1.2	0.4
15.0	D	T520D156M025A(1)E060	38	10	60	1.6	0.5
15.0	D	T520D156M025A(1)E080	38	10	80	1.4	0.4

(1) To complete the KEMET part number, insert the lead material designator as shown on page 46.

POLYMER TANTALUM CHIP CAPACITORS

T525 SERIES - High Temperature



FEATURES

- Polymer Cathode Technology
- 125°C Maximum Temperature Capability
- High Frequency Capacitance Retention
- Non-Ignition Failure Mode
- Capacitance: 33 - 180µF
- Voltage: 2.5 to 16 volts
- Halogen Free Epoxy
- Use up to 80% of Rated Voltage (10% Derating) for part types ≤ 10 Volts
- Use up to 80% of Rated Voltage (20% Derating) for part types > 10 Volts
- Operating Temperature -55°C to +125°C
- 100% Accelerated Steady State Aging
- 100% Surge Current Testing
- Self-Healing Mechanism
- Volumetrically Efficient
- Extremely Stable ESR at 125°C
- EIA Standard Case Size
- RoHS Compliant / Leadfree Termination (See www.kemet.com for lead transition)

OUTLINE DRAWING

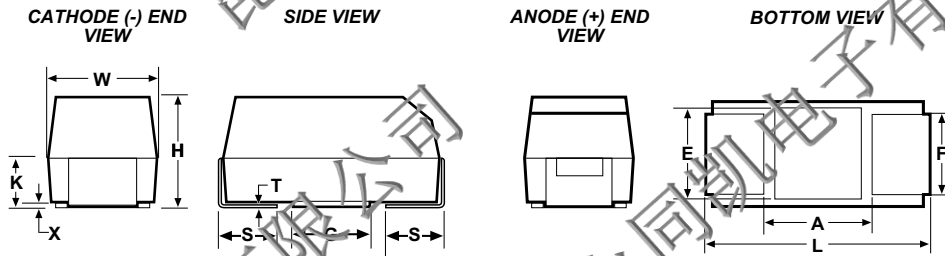

DIMENSIONS - MILLIMETERS

Case Size		L	W	H	K ±0.20	F ±0.1	S ±0.3	X (Ref)	T (Ref)	A (Min)	G (Ref)	E (Ref)
KEMET	EIA											
T	3528-12	3.5 ± 0.2	2.8 ± 0.2	1.2 max.	0.3	2.2	0.8	0.05	0.13	1.1	1.8	2.2
B	3528-21	3.5 ± 0.2	2.8 ± 0.2	1.9 ± 0.1	0.9	2.2	0.8	0.10 ± 0.10	0.13	1.1	1.8	2.2
D	7343-31	7.3 ± 0.3	4.3 ± 0.3	2.8 ± 0.3	1.5	2.4	1.3	0.10 ± 0.10	0.13	3.8	3.5	3.5

RECOMMENDED TEMPERATURE/VOLTAGE DERATING

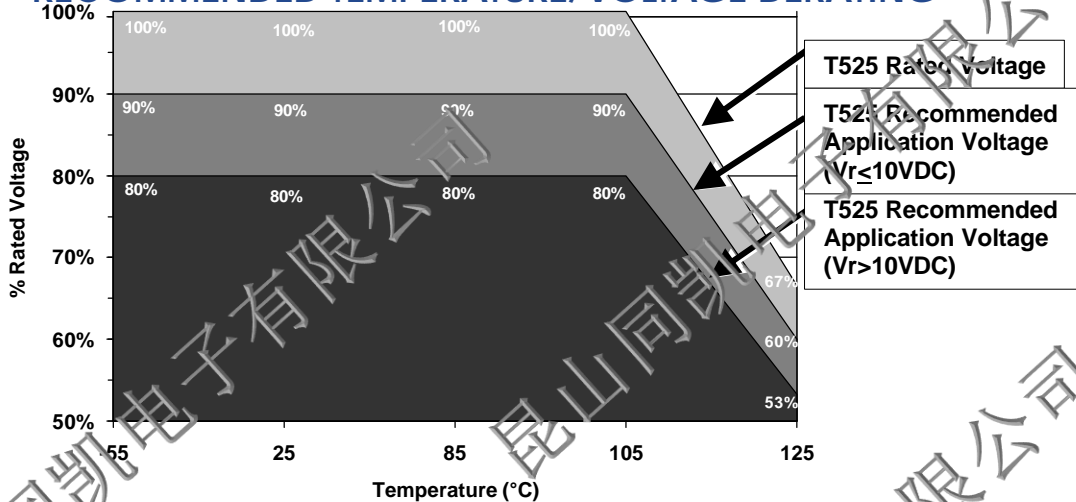

COMPONENT MARKING

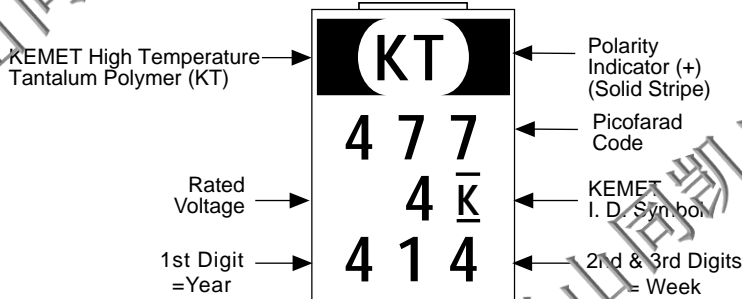

"414" = The 14th week of 2004

T525 RATINGS & PART NUMBER REFERENCE

Capacitance μ F	Case Size	KEMET Part Number	DC Leakage μ A @ 25°C Max	DF% @ 25°C 120 Hz Max	ESR mW @ 25°C 100 kHz Max	Ripple Current (Arms) 100 kHz Max	
						w/DT=20°C @ -55°C to 105°C	w/DT=2°C @ 125°C
2.5 Volt Rating at 105°C (1.7 Volt Rating at 125°C)							
100.0	T	T525T107M2R5A(1)E080	25	8.0	80	0.9	0.3
330.0	D	T525D337M2R5A(1)E025	83	10.0	25	2.4	0.8
470.0	D	T525D477M2R5A(1)E025	118	10.0	25	2.4	0.8
680.0	D	T525D687M2R5A(1)E025	170	10.0	25	2.4	0.8
3 Volt Rating at 105°C (2 Volt Rating at 125°C)							
100.0	B	T525B107M003A(1)E080	30	8.0	80	1.0	0.3
150.0	B	T525B157M003A(1)E080	45	8.0	80	1.0	0.3
330.0	D	T525D337M003A(1)E025	99	10.0	25	2.4	0.8
470.0	D	T525D477M003A(1)E025	141	10.0	25	2.4	0.8
680.0	D	T525D687M003A(1)E025	204	10.0	25	2.4	0.8
4 Volt Rating at 105°C (2.7 Volt Rating at 125°C)							
68.0	T	T525T686M004A(1)E080	27	8.0	80	0.9	0.3
68.0	B	T525B686M004A(1)E080	28	8.0	80	1.0	0.3
100.0	B	T525B107M004A(1)E080	40	8.0	80	1.0	0.3
220.0	D	T525D227M004A(1)E025	88	10.0	25	2.4	0.8
330.0	D	T525D337M004A(1)E025	132	10.0	25	2.4	0.8
470.0	D	T525D477M004A(1)E025	188	10.0	25	2.4	0.8
470.0	D	T525D477M004A(1)E040	188	10.0	40	1.9	0.6
6.3 Volt Rating at 105°C (4.2 Volt Rating at 125°C)							
33.0	B	T525B336M006A(1)E080	21	8.0	80	1.0	0.3
47.0	T	T525T476M006A(1)E080	30	8.0	80	0.9	0.3
47.0	B	T525B476M006A(1)E080	30	8.0	80	1.0	0.3
68.0	B	T525B686M006A(1)E080	43	8.0	80	1.0	0.3
150.0	D	T525D157M006A(1)E025	95	10.0	25	2.4	0.8
220.0	D	T525D227M006A(1)E025	139	10.0	25	2.4	0.8
330.0	D	T525D337M006A(1)E025	208	10.0	25	2.4	0.8
330.0	D	T525D337M006A(1)E040	208	10.0	40	1.9	0.6
10 Volt Rating at 105°C (6.6 Volt Rating at 125°C)							
33.0	B	T525B226M010A(1)E080	22	8.0	80	1.0	0.3
33.0	T	T525T336M006A(1)E080	33	8.0	80	0.9	0.3
33.0	B	T525B336M010A(1)E080	33	8.0	80	1.0	0.3
100.0	D	T525D107M010A(1)E025	100	10.0	25	2.4	0.8
100.0	D	T525D107M010A(1)E055	100	10.0	55	1.7	0.5
150.0	D	T525D157M010A(1)E025	150	10.0	25	2.4	0.8
150.0	D	T525D157M010A(1)E055	150	10.0	55	1.7	0.5
220.0	D	T525D227M010A(1)E025	220	10.0	25	2.4	0.8
16 Volt Rating at 105°C (10.6 Volt Rating at 125°C)							
47.0	D	T525D476M016A(1)E035	76	10.0	35	2.1	0.7
47.0	D	T525D476M016A(1)E065	76	10.0	65	1.5	0.5

(1) To complete the KEMET part number, insert the lead material designator as shown below.

T525 ORDERING INFORMATION

T 525 D 337 M 006 A 1 E040

Tantalum

Series

T525 - High Temperature
Tantalum Polymer (KTY)

Case Size

T, B, D

Capacitance Picofarad Code

First two digits represent significant figures.
Third digit specifies number of zeros to follow.

ESP

Lead Material
T - 100% Tin (Sn)

Failure Rate

A - Not Applicable

Voltage

Note: 006 - 6.3

Capacitance Tolerance

M = \pm 20%

POLYMER TANTALUM CHIP CAPACITORS

T530 SERIES - Multiple Anode



FEATURES

- Highest CV in Standard EIA Size
- Extremely Low ESR
- 125°C Max. Temperature Capability
- Polymer Cathode Technology
- High Frequency Capacitance Retention
- Non-Ignition Failure Mode
- Capacitance: 220 to 1500 μ F
- Voltage: 2.5V to 10V
- Molded Case (pick-and-place precision)
- 100% Accelerated Steady State Aging
- 100% Surge Current Testing
- Utilizes Multiple Tantalum Anode Technology
- Volumetric Efficiency
- Use Up to 90% of Rated Voltage (10% Derating)
- Self-Healing Mechanism
- True SMT Capability

OUTLINE DRAWINGS

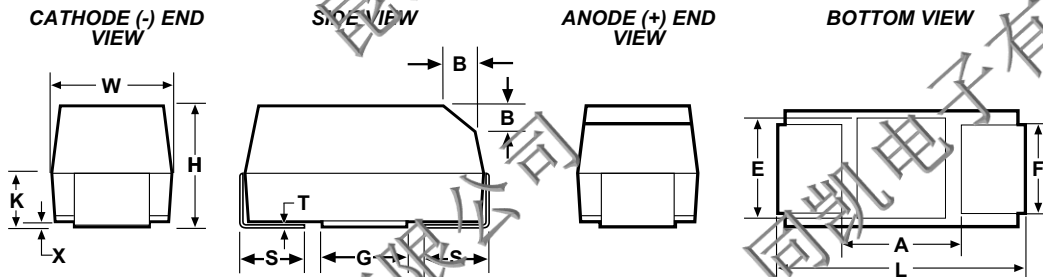

DIMENSIONS - MILLIMETERS (INCHES)

Case Size		L	W	H	K ± 0.20	F ± 0.1	S ± 0.3	X(Ref)	T(Ref)	A(Min)	G(ref)	E(ref)
KEMET	EIA											
D	7343-31	7.3 ± 0.3	4.3 ± 0.3	2.8 ± 0.3	1.5	2.4	1.3	0.10 ± 0.10	0.13	3.8	3.5	3.5
Y	7343-40	7.3 ± 0.3	4.3 ± 0.3	4.0 max	1.9	2.4	1.3	0.10 ± 0.10	0.13	3.8	3.5	3.5
X	7343-43	7.3 ± 0.3	4.3 ± 0.3	4.0 ± 0.3	2.3	2.4	1.3	0.10 ± 0.10	0.13	3.8	3.5	3.5

T530 SERIES RATINGS & PART NUMBER REFERENCE

Capacitance μ F	Case Size	KEMET Part Number	DCL V_R	DF % 120Hz	ESR mW @100 kHz 25°C Max	Ripple Current (Arms) @ 100 kHz	
						w/DT= 20°C @ -55°C to 105°C	w/DT= 2°C @ 125°C
2.5 Volt Rating at 105°C (1.7 Volt Rating at 125°C)							
470.0	D/7343-31	T530D477M2R5A(1)E005	118 μ A	8.0	5.0	7.1	2.3
470.0	D/7343-31	T530D477M2R5A(1)E006	118 μ A	8.0	6.0	6.5	2.1
470.0	D/7343-31	T530D477M2R5A(1)E010	118 μ A	10.0	10.0	5.0	1.6
560.0	D/7343-31	T530D567M2R5A(1)E005	140 μ A	8.0	5.0	7.1	2.3
680.0	Y/7343-40	T530Y687M2R5A(1)E005	170 μ A	8.0	5.0	7.2	2.3
680.0	Y/7343-40	T530Y687M2R5A(1)E006	170 μ A	8.0	6.0	6.6	2.1
680.0	D/7343-31	T530D687M2R5A(1)E010	170 μ A	8.0	6.0	6.5	2.1
680.0	D/7343-31	T530D687M2R5A(1)E011	170 μ A	8.0	10.0	5.0	1.6
1000.0	X/7343-43	T530X108M004A(1)E005	272 μ A	8.0	5.0	7.3	2.3
1000.0	X/7343-43	T530X108M004A(1)E006	272 μ A	8.0	6.0	6.7	2.1
1500.0	X/7343-43	T530X158M003A(1)E005	375 μ A	8.0	5.0	7.1	2.3
3 Volt Rating at 105°C (2 Volt Rating at 125°C)							
470.0	D/7343-31	T530D477M003A(1)E010	141 μ A	8.0	10.0	5.0	1.6
680.0	D/7343-31	T530D687M003A(1)E010	204 μ A	8.0	10.0	6.0	1.6
1000.0	X/7343-43	T530X108M003A(1)E010	300 μ A	8.0	10.0	5.2	1.6
1500.0	X/7343-43	T530X158M003A(1)E008	450 μ A	8.0	8.0	5.8	1.8
4 Volt Rating at 105°C (2.7 Volt Rating at 125°C)							
330.0	D/7343-31	T530D337M004A(1)E005	132 μ A	8.0	5.0	7.1	2.3
330.0	D/7343-31	T530D337M004A(1)E006	132 μ A	8.0	6.0	6.5	2.1
470.0	D/7343-31	T530D477M004A(1)E010	188 μ A	8.0	10.0	5.0	1.6
470.0	D/7343-31	T530D477M004A(1)E011	188 μ A	8.0	10.0	5.0	1.6
470.0	Y/7343-40	T530Y477M004A(1)E005	188 μ A	8.0	5.0	7.2	2.3
470.0	Y/7343-40	T530Y477M004A(1)E006	188 μ A	8.0	6.0	6.6	2.1
680.0	X/7343-43	T530X687M004A(1)E005	272 μ A	8.0	5.0	7.3	2.3
680.0	X/7343-43	T530X687M004A(1)E006	272 μ A	8.0	6.0	6.7	2.1
680.0	X/7343-43	T530X687M004A(1)E010	272 μ A	8.0	10.0	5.2	1.6
700.0	X/7343-43	T530X108M004A(1)E006	400 μ A	8.0	6.0	6.7	2.1
6.3 Volt Rating at 105°C (4.2 Volt Rating at 125°C)							
220.0	D/7343-31	T530D227M006A(1)E005	139 μ A	8.0	5.0	7.1	2.3
220.0	D/7343-31	T530D227M006A(1)E006	139 μ A	8.0	6.0	6.5	2.1
330.0	D/7343-31	T530D337M006A(1)E010	208 μ A	8.0	10.0	5.0	1.6
330.0	Y/7343-40	T530Y337M006A(1)E005	208 μ A	8.0	5.0	7.2	2.3
330.0	Y/7343-40	T530Y337M006A(1)E006	208 μ A	8.0	6.0	6.6	2.1
330.0	Y/7343-40	T530Y337M006A(1)E010	208 μ A	8.0	10.0	5.1	1.6
470.0	X/7343-43	T530X477M006A(1)E005	296 μ A	8.0	5.0	7.3	2.3
470.0	X/7343-43	T530X477M006A(1)E006	296 μ A	8.0	6.0	6.7	2.1
470.0	X/7343-43	T530X477M006A(1)E010	296 μ A	8.0	10.0	5.2	1.6
10 Volt Rating at 105°C (6.6 Volt Rating at 125°C)							
150.0	D/7343/31	T530D157M010A(1)E005	150 μ A	8.0	5.0	7.1	2.3
150.0	D/7343/31	T530D157M010A(1)E006	150 μ A	8.0	6.0	6.5	2.1
220.0	D/7343/31	T530D227M010A(1)E006	220 μ A	8.0	6.0	6.5	2.1
220.0	D/7343/31	T530D227M010A(1)E010	220 μ A	8.0	10.0	5.0	1.6
220.0	Y/7343/40	T530Y227M010A(1)E006	220 μ A	8.0	6.0	6.6	2.1
330.0	X/7343-43	T530X337M010A(1)E005	330 μ A	8.0	5.0	7.3	2.3
330.0	X/7343-43	T530X337M010A(1)E006	330 μ A	8.0	6.0	6.7	2.1
330.0	X/7343-43	T530X337M010A(1)E010	330 μ A	8.0	10.0	5.2	1.6

(1) To complete the KEMET part number, insert the lead material designator as shown on page 52.

T530 ORDERING INFORMATION

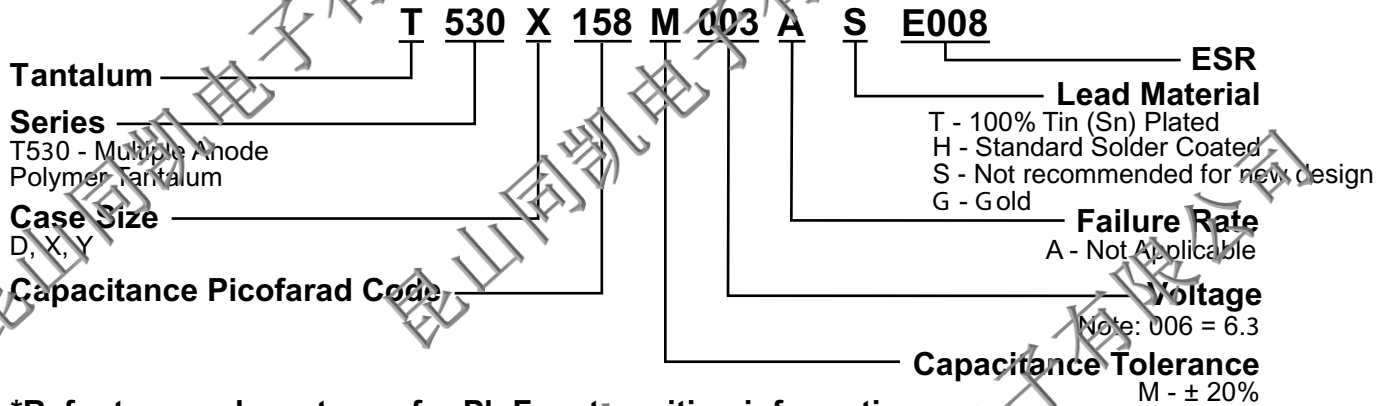

*Refer to www.kemet.com for Pb Free transition information

COMPONENT MARKING

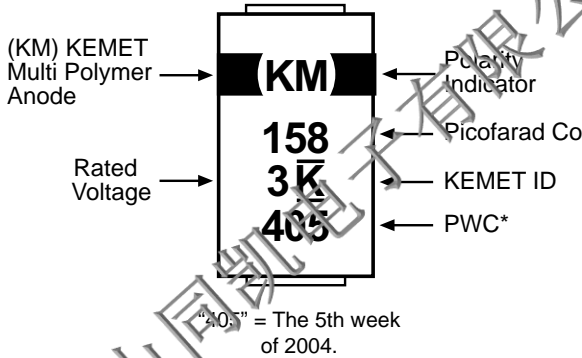

T530 SERIES CONSTRUCTION



T530X/T510E/T491E 1,000µF Capacitance vs. Frequency

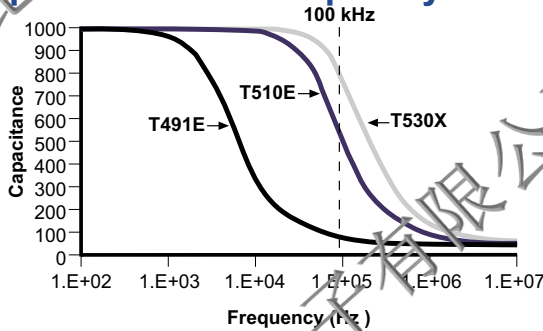

T530X/T510E/T491E 1,000µF Impedance & ESR vs. Frequency

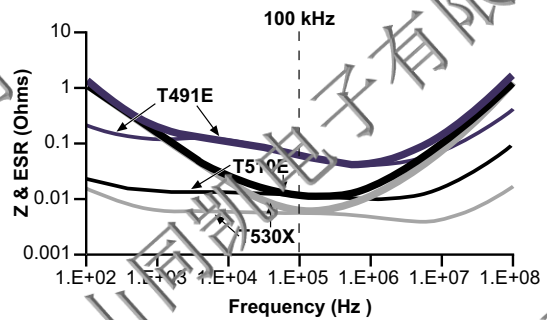

RECOMMENDED TEMPERATURE/VOLTAGE DERATING

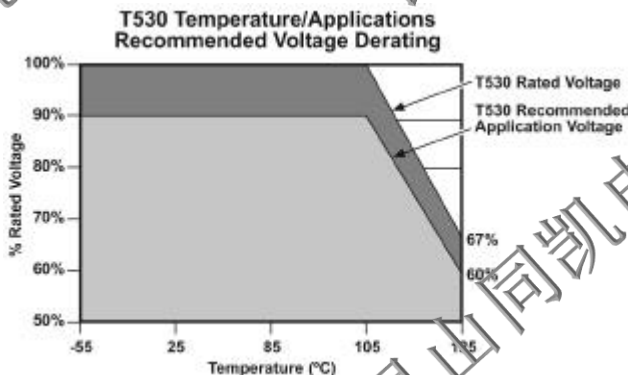

Tape & Reel Packaging

KEMET's Molded Tantalum Chip Capacitor families are packaged in 8 mm and 12 mm plastic tape on 7" and 13" reels, in accordance with EIA Standard 481-1: Taping of Surface Mount Components for Automatic Handling. This packaging system is compatible with all tape fed automatic pick and place systems.

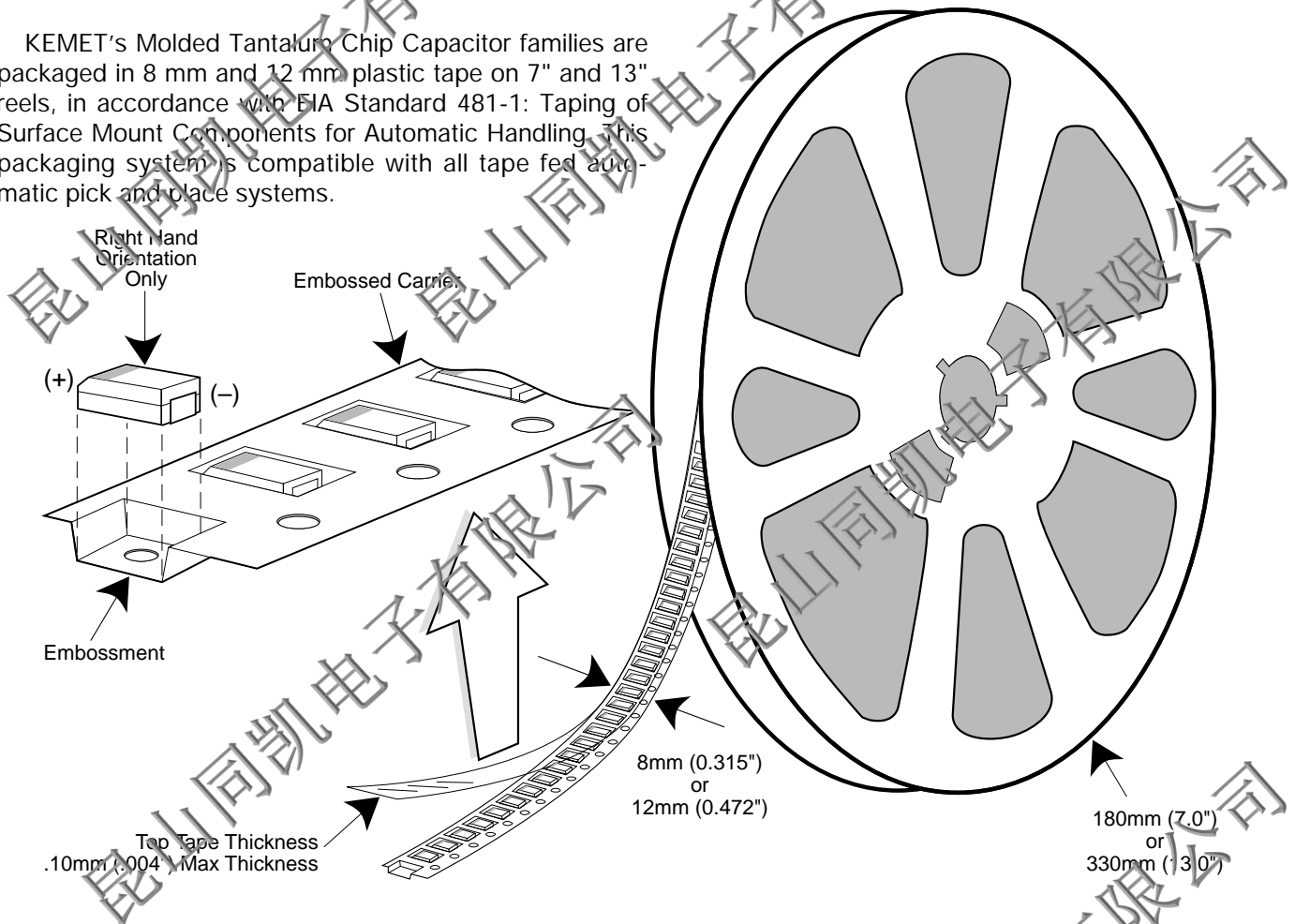

Labeling: Bar code labeling (standard or custom) shall be on the side of the reel opposite the sprocket holes. Refer to EIA-556.

QUANTITIES PACKAGED PER REEL

Case Code		Tape Width-mm	7" Reel	13" Reel*
KEMET	EIA			
R	2012-12	8	2,500	10,000
S	3216-12	8	2,500	10,000
	3528-12	8	2,500	10,000
	6032-15	12	1,000	5,000
V	7343-20	12	1,000	3,000
	A	3216-18	8	2,000
B	3528-21	8	2,000	8,000
C	6032-28	12	500	3,000
D	7343-31	12	500	2,500
Y	7343-40	12	500	2,000
X	7343-43	12	500	2,000
E	7260-38	12	500	2,000

* No c-spec required for 7" reel packaging. C-7280 required for 13" reel packaging.

Performance Notes

- Cover Tape Break Force:** 1.0 Kg Minimum.
- Cover Tape Peel Strength:** The total peel strength of the cover tape from the carrier tape shall be:

Tape Width	Peel Strength
8 mm	0.1 Newton to 1.0 Newton (10g to 100g)
12 mm	0.1 Newton to 1.3 Newton (10g to 130g)

The direction of the pull shall be opposite the direction of the carrier tape travel. The pull angle of the carrier tape shall be 165° to 180° from the plane of the carrier tape. During peeling, the carrier and/or cover tape shall be pulled at a velocity of 300 ±10 mm/minute.
- Reel Sizes:** Molded tantalum capacitors are available on either 180 mm (7") reels (standard) or 330 mm (13") reels (with C-7280). Note that 13" reels are preferred.
- Labeling:** Bar code labeling (standard or custom) shall be on the side of the reel opposite the sprocket holes. Refer to EIA-556.

Embossed Carrier Tape Configuration: Figure 1

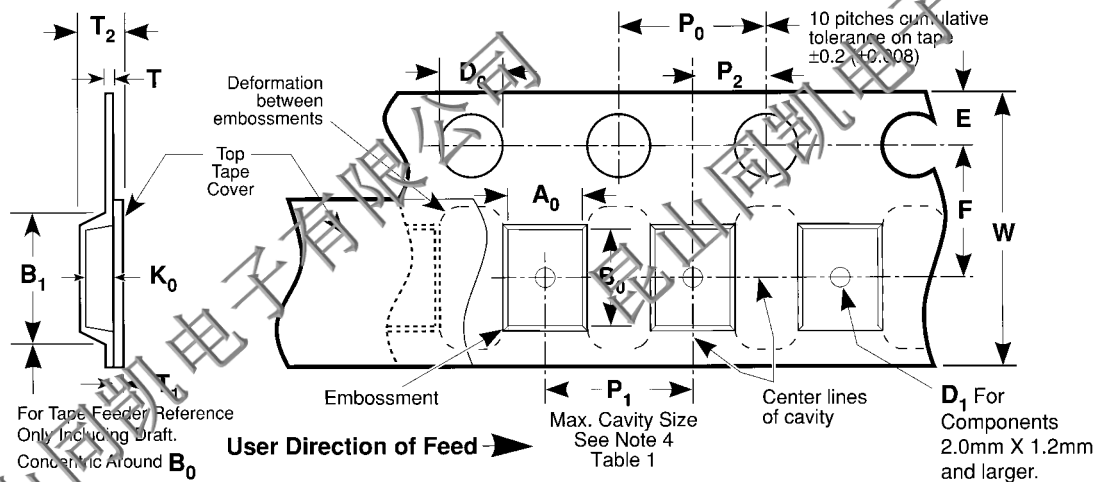

Table 1 — EMBOSSED TAPE DIMENSIONS (Metric will govern)

Constant Dimensions — Millimeters (Inches)									
Tape Size	D ₀	E	P ₀	P ₂	T Max	T ₁ Max			
8 mm and 12 mm	1.5 +0.10 -0.0 (0.059 +0.004, -0.0)	1.75 ±0.10 (0.069 ±0.004)	4.0 ±0.10 (0.157 ±0.004)	2.0 ±0.05 (0.079 ±0.002)	0.600 (0.024)	0.100 (0.004)			
Variable Dimensions — Millimeters (Inches)									
Tape Size	Pitch	B ₁ Max. Note 1	D ₁ Min. Note 2	F	P ₁	R Min. Note 3	T ₂ Max	W	A ₀ B ₀ K ₀ Note 4
8 mm	Single (4 mm)	4.4 (0.173)	1.0 (0.039)	3.5 ±0.05 (0.138 ±0.002)	4.0 ±0.10 (0.157 ±0.004)	25.0 (0.984)	2.5 (0.098)	8.0 ±0.30 (.315 ±0.012)	
12 mm	Double (8 mm)	3.2 (0.323)	1.5 (0.059)	5.5 ±0.05 (0.217 ±0.002)	3.0 ±0.10 (0.315 ±0.004)	30.0 (1.181)	4.6 (0.181)	12.0 ±0.30 (0.472 ±0.012)	

NOTES

- B1 dimension is a reference dimension for tape feeder clearance only.
- The embossment hole location shall be measured from the sprocket hole controlling the location of the embossment. Dimensions of embossment location and hole location shall be applied independent of each other.
- Tape with components shall pass around radius "R" without damage (see sketch A). The minimum trailer length (Fig. 2) may require additional length to provide R min. for 12 mm embossed tape for reels with hub diameters approaching N min. (Table 2)
- The cavity defined by A₀, B₀, and K₀ shall be configured to surround the part with sufficient clearance such that the chip does not protrude beyond the sealing plane of the cover tape, the chip can be removed from the cavity in a vertical direction without mechanical restriction, rotation of the chip is limited to 20 degrees maximum in all 3 planes, and lateral movement of the chip is restricted to 0.5 mm maximum in the pocket (not applicable to vertical clearance.)

Embossed Carrier Tape Configuration (cont.)

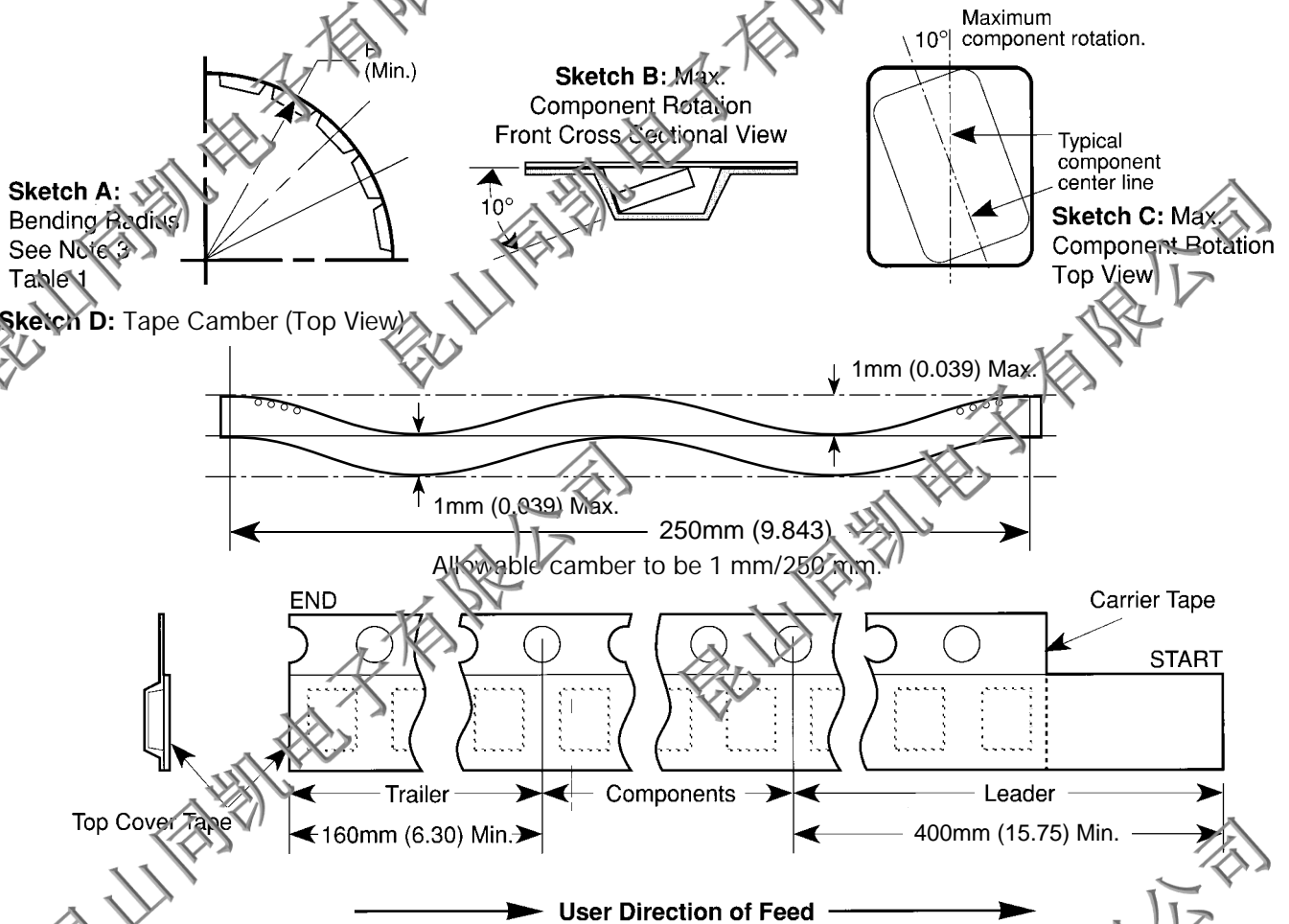

Figure 2: Tape Leader & Trailer Dimensions (Metric Dimensions Will Govern)

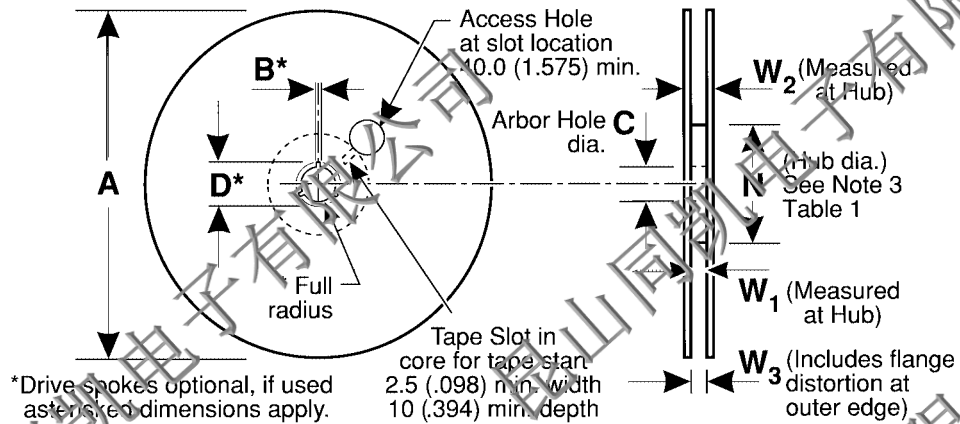

Figure 3: Reel Dimensions (Metric Dimensions will govern)

Table 2 – REEL DIMENSIONS (Metric will govern)

Tape Size	A Max	B* Min	C	D* Min	N Min	W ₁	W ₂ Max	W ₃
8 mm	330.0 (12.992)	1.5 (0.059)	13.0 ± 0.20 (0.512 ± 0.008)	20.2 (0.795)	50.0 (1.969) See Note 3 Table 1	8.4 1.5, -0.0 (0.331 -0.059, -0.0)	14.4 (0.567)	7.9 Min (0.311) 10.9 Max (0.429)
12 mm	330.0 (12.992)	1.5 (0.059)	13.0 ± 0.20 (0.512 ± 0.008)	20.2 (0.795)	Table 1	12.4 +2.0, -0.0 (0.488 +0.078, -0.0)	18.4 (0.724)	11.9 Min (0.469) 15.4 Max (0.606)